

Circulation Stool

Don't Sweat It™

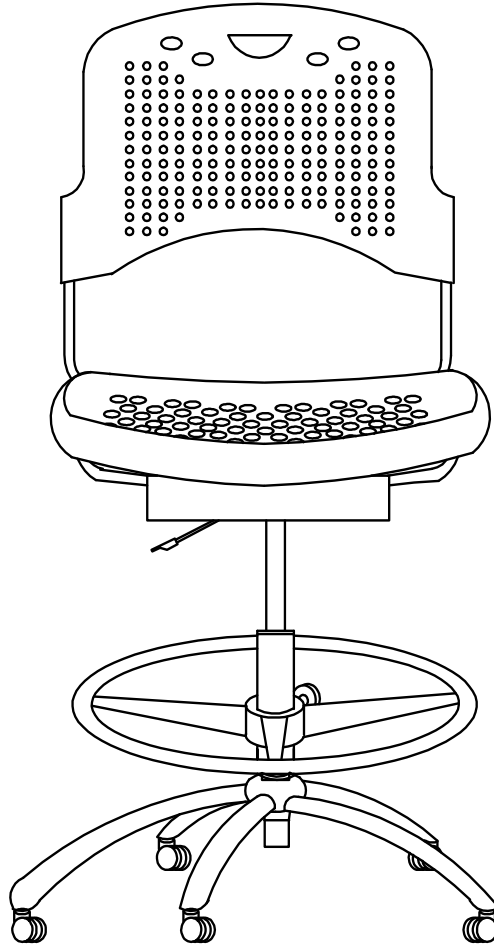

Important

The product you have purchased is guaranteed against material and workmanship defects. This guarantee extends 1 year from date of purchase. Should this product fail to function satisfactorily under normal use due to defect or imperfection, the defective part or product will be replaced. Damage caused by common carriers during shipment is not included in this guarantee.

This guarantee sets forth all applicable guarantees and remedies. No other warranty, expressed or implied shall apply. Failure to follow instructions found in Important Information Section of Owner Sheet shall void the guarantee. Consequential or incidental damages and or costs are not refundable.







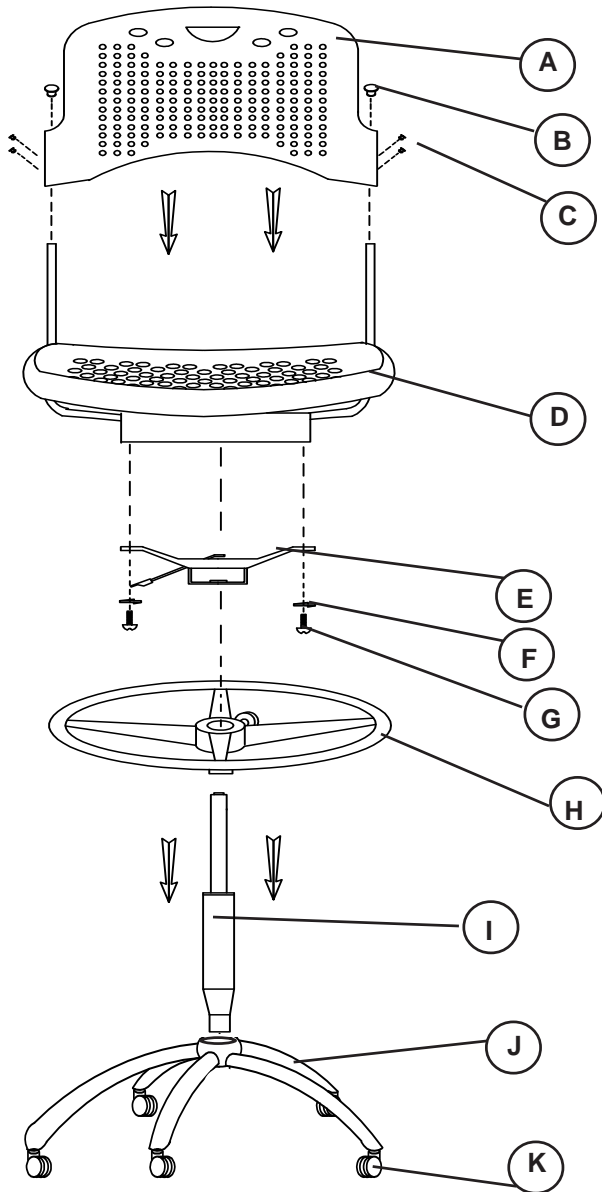

Do not use unless all screws are tight. At least every six months, check all screws to be sure they are tight. If parts are missing, broken, damaged, or worn, stop use of the product until repairs are made by your dealer using factory authorized parts.

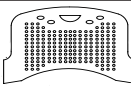
Circulation Stool

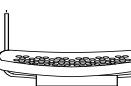
Don't Sweat It™

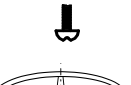
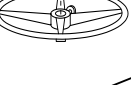
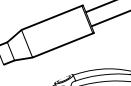

Part / Hardware List

| Part | Drawing | Description | Qty |
|------|---|--------------------|------|
| A |  | Stool Back | 1 EA |
| B |  | Backpost Plug | 2 EA |
| C |  | Back Push Pin | 4 EA |
| D |  | Seat Assembly | 1 EA |
| E |  | Lever Control | 1 EA |
| F |  | Lock Washer | 4 EA |
| G |  | Bolt | 4 EA |
| H |  | Foot Ring | 1 EA |
| I |  | Pneumatic Cylinder | 1 EA |
| J |  | Base | 1 EA |
| K |  | Caster | 5 EA |

Assembly Instructions

1. Separate and identify all parts.
2. Place Stool Back (A) on backpost tubes of Seat Assembly (D).
3. Align holes in Stool Back with holes in the backpost tubes and insert 4 Back Push Pins (C) into the holes.
4. Bolt the Lever Control (E) to the bottom of the Seat Assembly (D) using 4 Bolts (G) with 4 Lock Washers (F).
5. Push in 5 Casters (K) into the holes in the bottom of Base (J).
6. Insert the Pneumatic Cylinder (I) into the Base (J).
7. Slide the Foot Ring (H) down onto the Pneumatic Cylinder (I).
8. Place the Seat and Back assembly from Step #4 onto the Pneumatic Cylinder (I).
9. Set Foot Ring at height and tighten knob to secure in place.