

INSTALLATION DRAWING

360° BASE MOUNTED PILLAR JIB CRANE MODEL 747090

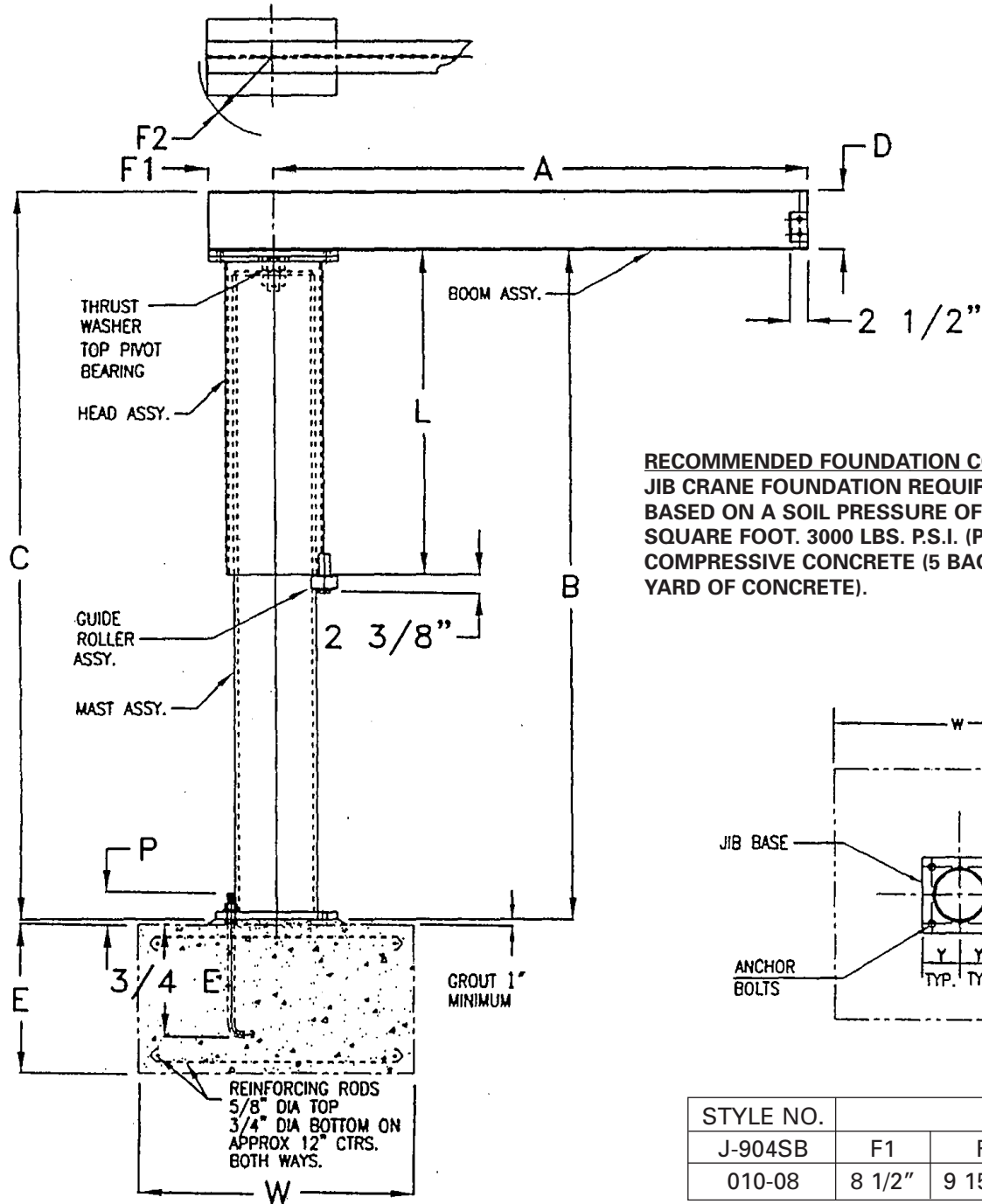

RECOMMENDED FOUNDATION CONCRETE
 JIB CRANE FOUNDATION REQUIREMENTS ARE
 BASED ON A SOIL PRESSURE OF 2500 LBS. PER
 SQUARE FOOT. 3000 LBS. P.S.I. (PER SQ. INCH)
 COMPRESSIVE CONCRETE (5 BAG MIX-ONE
 YARD OF CONCRETE).

CAPACITY:	2000 LBS.
WEIGHT:	995 LBS.
A	8'-0"
B	12'-0"
C	12'-8"
D	W8" X 21#
E	3'-0"
W	5'-0"

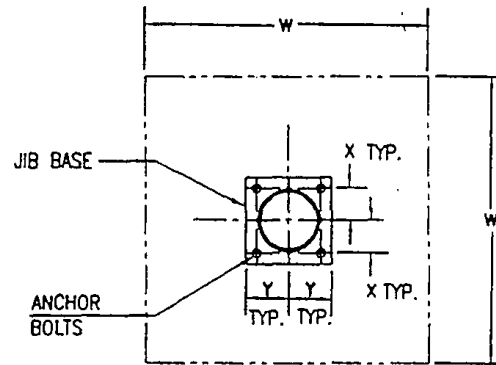

STYLE NO.	DIMENSIONS					ANCHOR BOLT	
	F1	F2	X	Y	L	P	DIA.
J-904SB	F1	F2	X	Y	L	P	DIA.
010-08	8 1/2"	9 15/16"	6"	8"	4'-3/4"	4"	1"