

# Model SOP50

Portable Gravity Fed Eyewash Station



## SPECIFICATIONS:

Model SOP50 portable eyewash station shall include a polyethylene 18 gallon tank, no moving parts and can be wall mounted or placed on a countertop or other flat surface. Eyewash heads provide a minimum of 0.4 gpm flow rate for 15 minutes and include a yellow eyewash pull strap for ease of activation. Tank includes integral handles on the top and sides, wide fill opening with threaded cap, highly visible identification/operation label and inspection/maintenance label. Unit is supplied with a heavy duty stainless steel wall bracket and one bottle of water preservative to permit storage of water for up to six months.

## STANDARD EQUIPMENT:

**Tank:** Highly visible yellow, UV protected polyethylene tank, with no moving parts.

**Eyewash:** ABS plastic eyewash heads with easy activation removable pull strap will deliver a minimum water flow of 0.4 gpm [1.5 liters] for 15 minutes. Pull strap caps form an air tight seal which prevents dust and debris from collecting on the eyewash heads.

**Mounting:** A J-shaped heavy duty stainless steel wall bracket for wall mounting allows easy removal and remounting of the eyewash station. The eyewash station can also be placed on a countertop or other flat surface.

**Drain hose:** Supplied with three feet of 1/2" ID drain hose.

**Labels:** Highly visible high gloss identification/operation label and inspection/maintenance label are fixed to the face of the tank.

**Water preservative:** One container of concentrated water preservative is supplied with each eyewash station to increase the storage life of the water.

**Weekly inspection tag:** A waterproof test card to record the date and inspector's name, for weekly inspection of the eyewash station.

## APPLICATION:

Ideal for low traffic or remote areas where a person's eyes may be exposed to injurious or corrosive materials and there is no immediately available supply of potable water. The eyewash station can be wall mounted or may be placed on a countertop or other suitable flat surface. The eyewash station must be installed per **ANSI Z358.1-2009**.

Model: SOP50



## OPTIONAL ACCESSORIES:

Additional costs may be incurred

- PWP Potable Water Preservative (4) Pack



Member of  
U.S. Green  
Building Council



Recyclable  
Product

Acorn Safety assumes no responsibility for use of void or superseded data. © Copyright Acorn Safety®, City of Industry, CA, Division of Acorn Engineering Company®, Member of Morris Group International™. Please visit [www.acorneng.com](http://www.acorneng.com) for most current specifications.

Submittal # **SOP50**  
[EW] Date: 05/20/13

Product carries the following certifications:



Test rating conditions are compliant to ANSI Z358.1-2009



Division of  
Acorn Engineering Company®,  
Member of  
Morris Group International™

**ACORN SAFETY**

P.O. Box 3527  
City of Industry, CA  
91744 U.S.A.

Phone 800-591-9372  
626-855-4804

[www.acorneng.com](http://www.acorneng.com)

# TECHNICAL DIMENSIONS

All dimensions are subject to manufacturer's tolerance of plus or minus 1/2" nominal and subject to change without notice. Acorn Safety® assumes no responsibility for use of void or superseded data. Dimensions may change with the addition of optional accessories. © Acorn Safety®, A Division of Acorn Engineering Company®, Member of Morris Group International™. Please visit [www.acorneng.com](http://www.acorneng.com) for most current specifications.

**Model SOP50 : Portable Gravity Fed Eyewash Station**

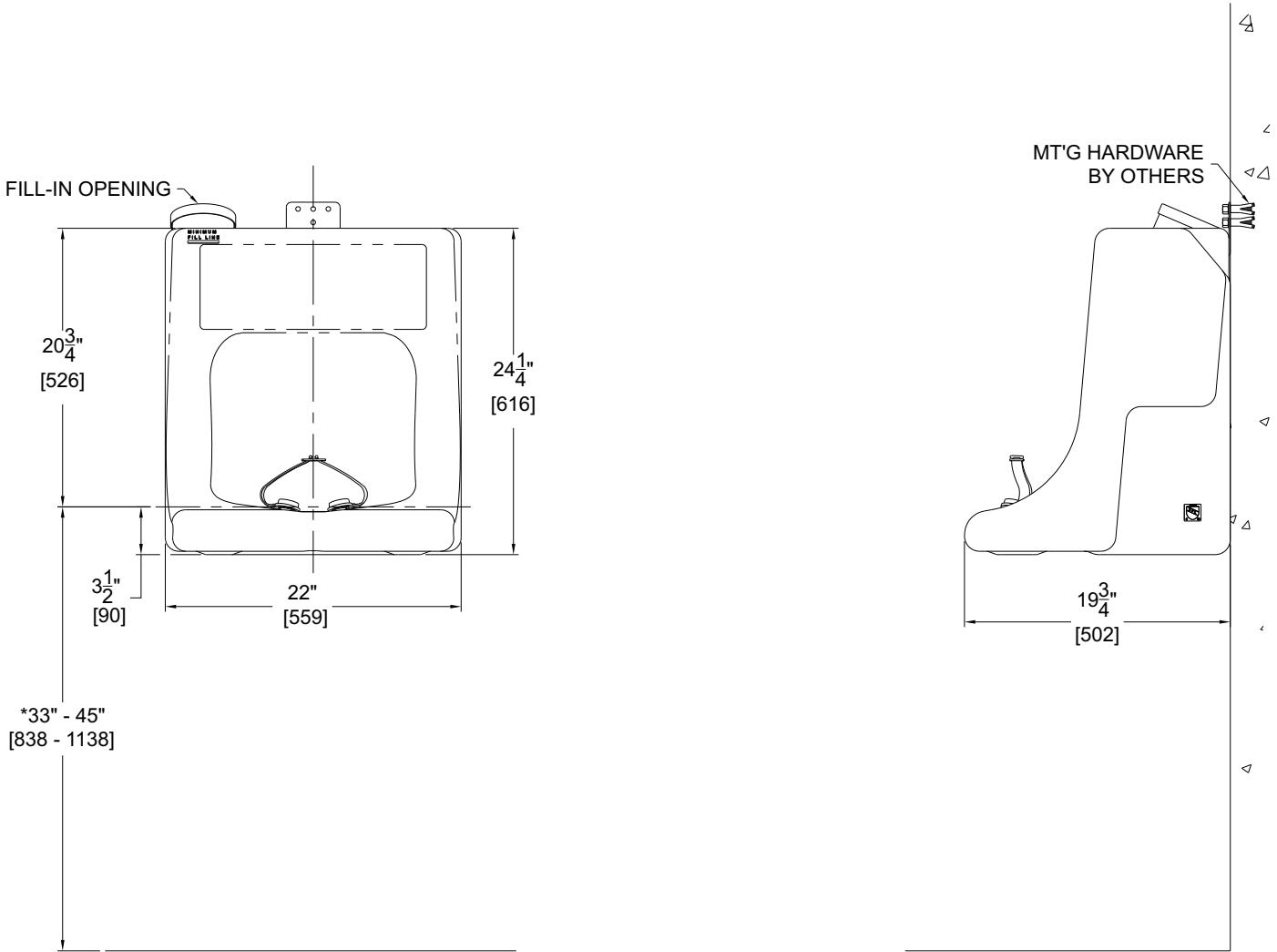

**GENERAL NOTES:**

1. ALL DIMENSIONS ARE IN INCHES [MM].
- \*2. ANSI Z358.1 REQUIRES NOZZLES TO BE MOUNTED BETWEEN 33" - 45" [838 - 1143] ABOVE THE FINISHED FLOOR.
3. TANK CAN ALSO BE PLACED ON A COUNTERTOP OR OTHER FLAT SURFACE.

**SOP50** Date: 05/20/13

Acorn Safety warrants that its products are free from defects in material or workmanship under normal use and service for a period of one year from date of shipment. Acorn's liability under this warranty shall be discharged solely by replacement or repair of defective material, provided Acorn is notified in writing within one year from date of shipment, F.O.B. Industry, California.

SELECTION SUMMARY & APPROVAL FOR MANUFACTURING

Model Number & Options \_\_\_\_\_ Quantity \_\_\_\_\_

Company \_\_\_\_\_

Contact \_\_\_\_\_ Title \_\_\_\_\_

Signature (Approval for Manufacturing) \_\_\_\_\_ Date \_\_\_\_\_



**800-591-9372**  
 or 626-855-4804  
[www.acorneng.com](http://www.acorneng.com)