

# INSTALLATION INSTRUCTIONS AND PARTS LIST TUBULAR GAS FIRED PROPELLER UNIT HEATERS

**ATTENTION: READ THIS MANUAL AND ALL LABELS ATTACHED TO THE UNIT CAREFULLY BEFORE ATTEMPTING TO INSTALL, OPERATE OR SERVICE THESE UNITS! CHECK UNIT DATA PLATE FOR TYPE OF GAS AND ELECTRICAL SPECIFICATIONS AND MAKE CERTAIN THAT THESE AGREE WITH THOSE AT THE POINT OF INSTALLATION. RECORD THE UNIT MODEL AND SERIAL No.(s) IN THE SPACE PROVIDED. RETAIN FOR FUTURE REFERENCE.**

Model No. \_\_\_\_\_ Serial No. \_\_\_\_\_

## FOR YOUR SAFETY

The use and storage of gasoline or other flammable vapors and liquids in open containers in the vicinity of this appliance is hazardous.



## FOR YOUR SAFETY

- If you smell gas:
1. Open windows.
  2. Don't touch electrical switches.
  3. Extinguish any open flame.
  4. Immediately contact your gas supplier.



**▲ WARNING** Improper installation, adjustment, alteration, service, or maintenance can cause property damage, injury, or death. Read the installation, operating, and maintenance instruction thoroughly before installing or servicing this equipment.

## APPROVED FOR USE IN CALIFORNIA

**▲ WARNING** Install, operate, and maintain unit in accordance with the manufacturer's instructions to avoid exposure to fuel substances, or substances from incomplete combustion, which can cause death or serious illness. The state of California has determined that these substances may cause cancer, birth defects, or other reproductive harm.

## INSTALLER'S RESPONSIBILITY

**Installer Please Note:** This equipment has been test fired and inspected. It has been shipped free from defects from our factory. However, shipment and installation problems such as loose wires, leaks, or loose fasteners may occur. **It is the installer's responsibility to inspect and correct any problem that may be found.**

## RECEIVING INSTRUCTIONS

Inspect shipment immediately when received to determine if any damage has occurred to the unit during shipment. After the unit has been uncrated, check for any visible damage to the unit. If any damage is found, the consignee should sign the bill of lading indicating such damage and immediately file claim for damage with the transportation company.

# TABLE OF CONTENTS

SPECIFICATIONS		VENTING .....	14, 15, 16, 17, 18
Basic Description .....	2	OPERATION	
Performance & Specification Data .....	4	Explanation of Controls and Operation .....	19
GENERAL SAFETY INFORMATION		Main Burner Orifice Schedule .....	20
Installation Codes .....	2, 3	Adjustments .....	20
Special Precautions .....	2, 3	TROUBLESHOOTING GUIDE .....	21, 22, 23, 24
INSTALLATION		WARRANTY .....	24
Locating Units .....	5, 6	MAINTENANCE	
Combustion Air .....	5, 6	Servicing & Cleaning .....	25
Proper Clearances .....	5, 6	IDENTIFICATION OF PARTS .....	4, 6, 19, 26, 27
Suspension of Units .....	5, 6	Replacement Parts .....	27
Gas Piping .....	7, 8	INSPECTION SHEET .....	28
ELECTRICAL CONNECTIONS .....	9, 10, 11, 12, 13		

**NOTICE:** It is the equipment owners responsibility to provide any scaffolding or other apparatus required to perform emergency service or annual/periodic maintenance to this equipment.

## DESCRIPTION

The Tubular Gas Fired Unit Heaters are a factory assembled, power vented, low static pressure type propeller fan unit heaters designed to be suspended within the space to be heated. THESE HEATERS ARE NOT TO BE CONNECTED TO DUCTWORK. The

designs are certified by CSA International as providing a minimum of 80% thermal efficiency, and approved for use in California. Do not alter these units in any way. If you have any questions after reading this manual, contact the manufacturer.

**Figure 1 - Tubular Propeller Unit Heater**



See Identification of Parts throughout this manual.

The following terms are used throughout this manual, in addition to the CSA requirements to bring attention to the presence of potential hazards, or to important information concerning the product:

**▲ DANGER** Indicates an imminently hazardous situation which, if not avoided, will result in death, serious injury, or substantial property damage.

**▲ WARNING** Indicates an imminently hazardous situation which, if not avoided, could result in death, serious injury, or substantial property damage.

**▲ CAUTION** Indicates an imminently hazardous situation which, if not avoided, may result in minor injury or property damage.

**NOTICE:** Used to notify of special instructions on installation, operation, or maintenance which are important to equipment but not related to personal injury.

# GENERAL SAFETY INFORMATION

**▲ WARNING** Failure to comply with the general safety information may result in extensive property damage, severe personal injury, or death.

**▲ WARNING** This product must be installed by a licensed plumber or gas fitter when installed within the Commonwealth of Massachusetts.

Installation must be made in accordance with local codes, or in absence of local codes, with ANSI Standard Z223.1-2002. (N.F.P.A. No.54) National Fuel Gas Code, or the latest edition of. All of the ANSI and NFPA Standards referred to in these installation instructions are those that were applicable at the time the design of this appliance was certified. The ANSI Standards are available from CSA Information Services, 1-800-463-6727. The NFPA Standards are available from the National Fire Protection Association, Batterymarch Park, Quincy, MA 02269. These unit heaters are designed for use in airplane hangars when installed in accordance with ANSI/NFPA No. 409, and in public garages when installed in accordance with NFPA No. 88A and NFPA No.88B.

If installed in Canada, the installation must conform with local building codes, or in the absence of local building codes, with CGA-B149.1 "Installation Codes for Natural Gas Burning Appliances and Equipment" or CGA-B149.2 "Installation Codes for Propane Gas Burning Appliances and Equipment." These unit heaters have been designed and certified to comply with CGA 2.6. Also see sections on installation in AIRCRAFT HANGARS and PUBLIC GARAGES.

**▲ WARNING** Do not alter the unit heater in any way or damage to the unit and/or severe personal injury or death may occur!

**▲ WARNING** Disconnect all power and gas supplies before installing or servicing the heater. If the power disconnect is out of sight, lock it in the open position and tag it to prevent unexpected application of power. Failure to do so could result in fatal electric shock, or severe personal injury.

**▲ CAUTION** Insure that all power sources conform to the requirements of the unit heater, or damage to the unit will result!

Follow installation instructions CAREFULLY to avoid creating unsafe conditions. All wiring should be done and checked by a qualified electrician, using copper wire only. All gas connections should be made and leak-tested by a suitably qualified individual, per instructions in this manual. Also follow procedures listed on "Gas Equipment Start-Up Sheet" located in this manual.

Use only the fuel for which the heater is designed (see rating plate). Using LP gas in a heater that requires natural gas, or vice versa, will create risk of gas leaks, carbon monoxide poisoning, and explosion.

**▲ WARNING** Do not attempt to convert the heater for use with a fuel other than the one intended. Such conversion is dangerous, as it will create the risks previously listed.

Make certain that the power source conforms to the electrical requirements of the heater.

**▲ WARNING** Do not depend upon a thermostat or other switch as sole means of disconnecting power when installing or servicing heater. Always disconnect power at main circuit breaker as described above. Failure to do so could result in fatal electric shock.

Special attention must be given to any grounding information pertaining to this heater. To prevent the risk of electrocution, the heater must be securely and adequately grounded. This should be accomplished by connecting a ground conductor between the service panel and the heater. To ensure a proper ground, the grounding means must be tested by a qualified electrician.

Do not insert fingers or foreign objects into heater or its air moving device. Do not block or tamper with the heater in any manner while in operation, or just after it has been turned off, as some parts may be hot enough to cause injury.

This heater is intended for general heating applications ONLY. It must NOT be used in potentially dangerous locations such as flammable, explosive, chemical-laden, or wet atmospheres.

Do not attach ductwork to this product or use it as a makeup air heater. Such usage voids the warranty and will create unsafe operation.

In cases in which property damage may result from malfunction of the heater, a back-up system or temperature sensitive alarm should be used.

**▲ CAUTION** The open end of piping systems being purged shall not discharge into areas where there are sources of ignition or into confined spaces UNLESS precautions are taken as follows: (1) by ventilation of the space, (2) control of the purging rate, (3) elimination of all hazardous conditions. All precautions must be taken to perform this operation in a safe manner!

Unless otherwise specified, the following conversions may be used for calculating SI unit measurements:

1 foot = 0.305 m	1000 BTU/cu. ft. = 37.5 MJ/m <sup>3</sup>
1 inch = 25.4 mm	1000 BTU per hour = 0.293 kW
1 gallon = 3.785 L	1 inch water column = 0.249 kPa
1 pound = 0.453 kg	1 litre/second = CFM x 0.472
1 psig = 6.894 kPa	1 meter/second = FPM ÷ 196.8
1 cubic foot = 0.028m <sup>3</sup>	

**Table 1 - Performance and Dimensional Data - Tubular Propeller Unit Heater**

Unit Size	100	125	150	175	200	250	300	350	400
<b>PERFORMANCE DATA†</b>									
Input - BTU/Hr.	100,000	125,000	150,000	175,000	200,000	250,000	300,000	350,000	400,000
(kW)	(29.3)	(36.6)	(43.9)	(51.2)	(58.6)	(73.2)	(87.8)	(102.5)	(117.1)
Output - BTU/Hr.	81,000	101,250	121,500	141,750	162,000	202,500	243,000	283,500	324,000
(kW)	(23.7)	(29.6)	(35.6)	(41.5)	(47.5)	(59.3)	(71.2)	(83.0)	(95.0)
Thermal Efficiency (%)	81	81	81	81	81	81	81	81	81
Free Air Delivery - CFM	1,600	2,200	2,400	2,850	3,200	3,450	5,000	5,600	5,800
(cu. m/s)	(0.756)	(1.039)	(1.133)	(1.346)	(1.511)	(1.629)	(2.361)	(2.644)	(2.738)
Air Temperature Rise - Deg. F	47	42	47	46	47	54	45	47	51
(Deg. C)	(26)	(23)	(26)	(26)	(26)	(30)	(24)	(26)	(28)
Full Load Amps at 120V	5.3	5.8	5.8	8.0	8.0	8.0	11.3	13.5	13.5
<b>MOTOR DATA: Motor HP (Qty.)</b>									
	1/10	1/4	1/4	1/3	1/3	1/3	(2) 1/4	(2) 1/3	(2) 1/3
Motor kW	(0.075)	(0.19)	(0.19)	(0.25)	(0.25)	(0.25)	(0.19)	(0.25)	(0.25)
Motor Type	SP	PSC	PSC	PSC	PSC	PSC	PSC	PSC	PSC
R.P.M.	1,050	1,140	1,140	1,140	1,140	1,140	1,140	1,140	1,140
Amps @ 115V	4.2	4.7	4.7	5.8	5.8	5.8	9.4	11.6	11.6
<b>DIMENSIONAL DATA - inches (mm)</b>									
"A" Overall Height to Top of Flue	33-3/4 (857)	33-3/4 (857)	33-3/4 (857)	33-3/4 (857)	33-3/4 (857)	33-3/4 (857)	34 (864)	34 (864)	34 (864)
"B" Jacket Width of Unit	20-3/4 (527)	20-3/4 (527)	20-3/4 (527)	32-3/4 (831)	32-3/4 (831)	32-3/4 (831)	50-3/4 (1289)	50-3/4 (1289)	50-3/4 (1289)
"C" Width to CL Flue	13-3/8 (340)	13-3/8 (340)	13-3/8 (340)	19-3/8 (492)	19-3/8 (492)	19-3/8 (492)	28-3/8 (721)	28-3/8 (721)	28-3/8 (721)
"D" Depth to Rear of Housing	11 (279)	11 (279)	11 (279)	11 (279)	11 (279)	11 (279)	12-1/4 (311)	12-1/4 (311)	12-1/4 (311)
"E" Hanging Distance Width	18-5/8 (473)	18-5/8 (473)	18-5/8 (473)	30-5/8 (778)	30-5/8 (778)	30-5/8 (778)	48-5/8 (1235)	48-5/8 (1235)	48-5/8 (1235)
"F" Discharge Opening Width	18-3/4 (476)	18-3/4 (476)	18-3/4 (476)	30-3/4 (781)	30-3/4 (781)	30-3/4 (781)	48-3/4 (1238)	48-3/4 (1238)	48-3/4 (1238)
"G" Depth to CL Flue	4-3/4 (121)	4-3/4 (121)	4-3/4 (121)	4-3/4 (121)	4-3/4 (121)	4-3/4 (121)	5-1/8 (130)	5-1/8 (130)	5-1/8 (130)
"H" Discharge Opening Height	24-1/2 (622)	24-1/2 (622)	24-1/2 (622)	24-1/2 (622)	24-1/2 (622)	24-1/2 (622)	24-1/2 (622)	24-1/2 (622)	24-1/2 (622)
"L" Overall Unit Width	25-1/4 (641)	25-1/4 (641)	25-1/4 (641)	37-1/4 (946)	37-1/4 (946)	37-1/4 (946)	55-1/4 (1403)	55-1/4 (1403)	55-1/4 (1403)
*Flue Size Diameter - in.	5	5	5	5	5	5	6	6	6
(Dia.-mm)	(127)	(127)	(127)	(127)	(127)	(127)	(152)	(152)	(152)
Fan Diameter - in. (Qty.)	16	16	16	18	18	18	(2) 16	(2) 18	(2) 18
Gas Inlet-Natural Gas (in.)	1/2	1/2	1/2	1/2	1/2	3/4	3/4	3/4	3/4
Gas Inlet- LP Gas (in.)	1/2	1/2	1/2	1/2	1/2	1/2 OR 3/4	1/2 OR 3/4	1/2 OR 3/4	1/2 OR 3/4
Approximate Unit Weight - lbs.	133	145	155	191	201	211	307	321	335
(kg)	(60)	(66)	(70)	(87)	(91)	(96)	(139)	(145)	(152)
Approximate Ship Weight - lbs.	173	185	195	241	251	261	367	381	395
(kg)	(78)	(84)	(88)	(109)	(114)	(118)	(166)	(173)	(179)

\* For all installations, the flue collar is included with the unit and should be field installed per the instructions included with the unit.

† Ratings shown are for unit installations at elevations between 0 and 2,000 ft. (0 to 610m). For unit installations in U.S.A. above 2,000 ft. (610m), the unit input must be derated 4% for each 1,000 ft. (305m) above sea level; refer to local codes, or in absence of local codes, refer to the National Fuel Gas Code, ANSI Standard Z223.1-2002 (N.F.P.A. No. 54), or the latest edition of.

For installations in Canada, any reference to deration at altitudes in excess of 2,000 ft. (610m) are to be ignored. At altitudes of 2,000 ft. to 4,500 ft. (610 to 1372m), the unit must be derated to 90% of the normal altitude rating, and be so marked in accordance with the CSA certification.

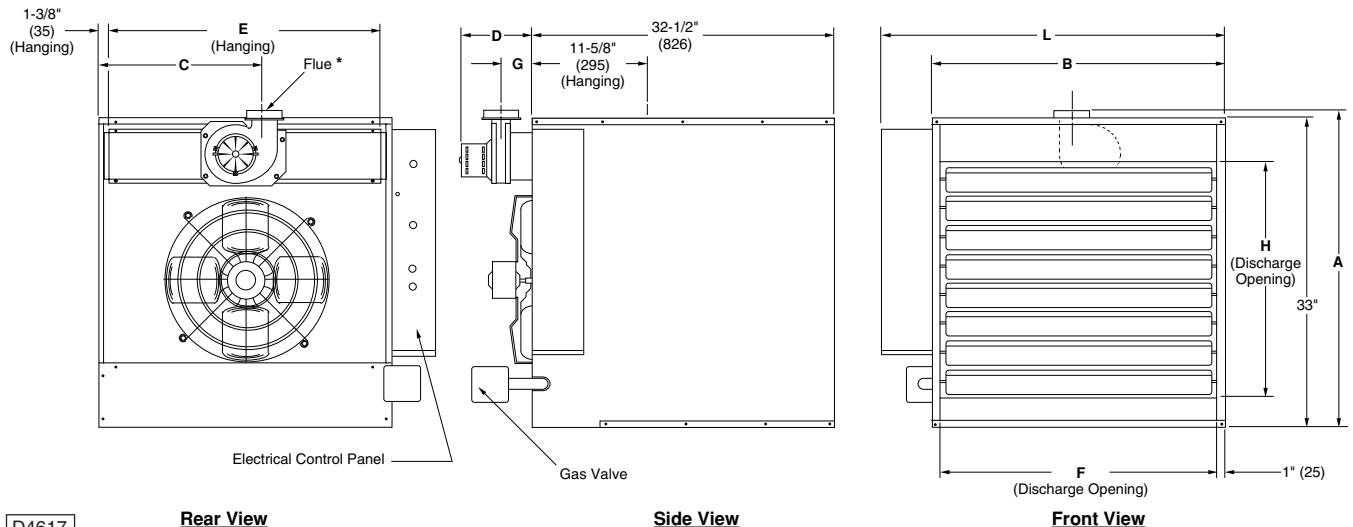

D4617

DIMENSIONS: XXX STANDARD UNITS  
DIMENSIONS IN PARENTHESIS (XXX) MILLIMETERS

**Figure 2 - Dimensional Drawing – Tubular Propeller Unit Heater**

# INSTALLATION

**▲ WARNING** Do not install unit heaters in corrosive or flammable atmospheres! Premature failure of, or severe damage to the unit will result!

**▲ WARNING** Avoid locations where extreme drafts can affect burner operation. Unit heaters must not be installed in locations where air for combustion would contain chlorinated, halogenated or acidic vapors. If located in such an environment, premature failure of the unit will occur!

Since the unit is equipped with an automatic gas ignition system, the unit heater must be installed such that the gas ignition control system is not directly exposed to water spray, rain or dripping water.

**NOTICE: Location of unit heaters is related directly to the selection of sizes. Basic rules are as follows:**

**MOUNTING HEIGHT:** Unit Heaters equipped with standard fan guards must be installed at a minimum of 8 feet (2.4m) above the floor, measured to the bottom of the unit. At heights above 8 feet (2.4m), less efficient air distribution will result. **If a unit is to be mounted below eight (2.4m) from the floor, an OSHA approved fan guard is required on the unit.**

**AIRCRAFT HANGARS:** Unit Heaters must be installed in aircraft hangars as follows: In aircraft hangars, unit heaters must be at least 10 feet (3.0m) above the upper surface of wings or engine enclosures of the highest aircraft to be stored in the hangar, and 8 feet (2.4m) above the floor in shops, offices and other sections of the hangar where aircraft are not stored or housed. Refer to current ANSI/NFPA No. 409, Aircraft Hangars. In Canada, installation is suitable in aircraft hangars when acceptable to the enforcing authorities.

**PUBLIC GARAGES:** In repair garages, unit heaters must be located at least 8 feet (2.4m) above the floor. Refer to the latest edition of NFPA 88B, Repair Garages.

In parking structures, unit heaters must be installed so that the burner flames are located a minimum of 18 in. (457mm) above the floor or protected by a partition not less than 18 in. (457mm) high. However, any unit heater mounted in a parking structure less than 8 ft. (2.4m) above the floor must be equipped with an OSHA approved fan guard. Refer to the latest edition of NFPA 88A, Parking structures.

In Canada, installation must be in accordance to the latest edition of CGA B149 "Installation Codes for Gas Burning Appliances and Equipment."

**AIR DISTRIBUTION:** Direct air towards areas of maximum heat loss. When multiple heaters are involved, circulation of air around the perimeter is recommended where heated air flows along exposed walls. Satisfactory results can also be obtained where multiple heaters are located toward the center of the area with heated air directed toward the outside walls. Be careful to avoid all obstacles and obstructions which could impede the warm air distribution patterns.

**Unit heaters should not be installed to maintain low temperatures and/or freeze protection of buildings. A minimum of 50°F (10°C) thermostat setting must be maintained.** If unit heaters are operated to maintain lower than 50°F (10°C), hot flue gases are cooled inside the heat exchanger to a point where water vapor (a flue gas by-product) condenses onto the heat exchanger walls. The result is a mildly corrosive acid that prematurely corrodes the aluminized heat exchanger and can actually drip water down from the unit heater onto floor surface. Additional unit heaters should be installed if a minimum 50°F (10°C) thermostat setting cannot be maintained.

**AIR FOR COMBUSTION:** The unit heater shall be installed in a location in which the facilities for ventilation permit satisfactory combustion of gas, proper venting, and the maintenance of ambient air at safe limits under normal conditions of use. The unit heater shall be located in such a manner as not to interfere with proper circulation of air within the confined space. When buildings are so tight that normal infiltration does not meet air requirements, outside air shall be introduced per Sections 1.3.4.2 and 1.3.4.3 of ANSI Z223.1 for combustion requirements. A permanent opening or openings having a total free area of not less than one square inch per 5,000 BTU/Hr (1.5 kW) of total input rating of all appliances within the space shall be provided.

**NOTICE: Unit Heater sizing should be based on heat loss calculations where the unit heater output equals or exceeds heat loss.**

# INSTALLATION (continued)

**CLEARANCES:** Each Gas Unit Heater shall be located with respect to building construction and other equipment so as to permit access to the Unit Heater. Clearance between vertical walls and the vertical sides of the Unit Heater shall be no less than 6 inches (152mm). However, to ensure access to the control box, a minimum of 18" (457mm) is required for the control box side. A minimum clearance of 6 inches (152mm) must be maintained between the top of the Unit Heater and the ceiling. The bottom of the Unit Heater must be no less than 12 inches (305mm) from any combustible. The distance between the flue collector and any combustible must be no less than 6 inches (152mm). Also see AIR FOR COMBUSTION and VENTING sections.

**NOTICE:** Increasing the clearance distances may be necessary if there is a possibility of distortion or discoloration of adjacent materials.

**▲ WARNING** Make certain that the lifting methods used to lift the heater and the method of suspension used in the field installation of the heater are capable of uniformly supporting the weight of the heater at all times. Failure to heed this warning may result in property damage or personal injury!

**▲ WARNING** Make sure that the structure to which the unit heater is to be mounted is capable of safely supporting its weight. Under no circumstances must the gas lines, the venting system or the electrical conduit be used to support the heater; or should any other objects (i.e. ladder, person) lean against the heater gas lines, venting system or the electrical conduit for support. Failure to heed these warnings may result in property damage, personal injury, or death.

**▲ CAUTION** Unit Heaters must be hung level from side to side and from front to back, see Figure 3A, 3B and 3C. Failure to do so will result in poor performance and /or premature failure of the unit.

**▲ WARNING** Ensure that all hardware used in the suspension of each unit heater is more than adequate for the job. Failure to do so may result in extensive property damage, severe personal injury, or death!

Refer to Figures 3A, 3B and 3C for suspension of units.

Figure 3A

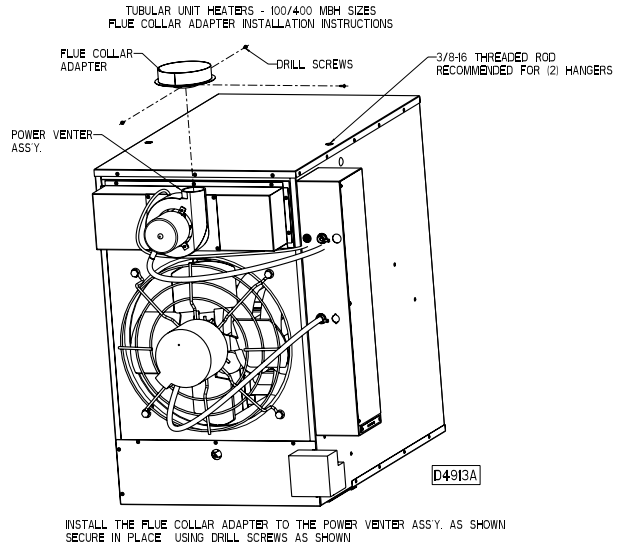
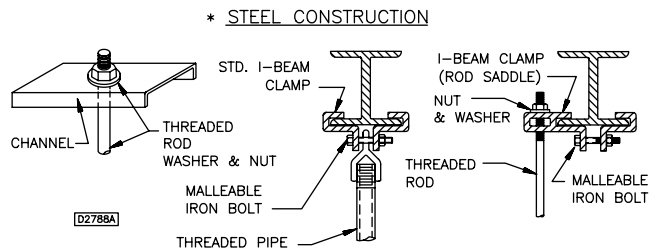
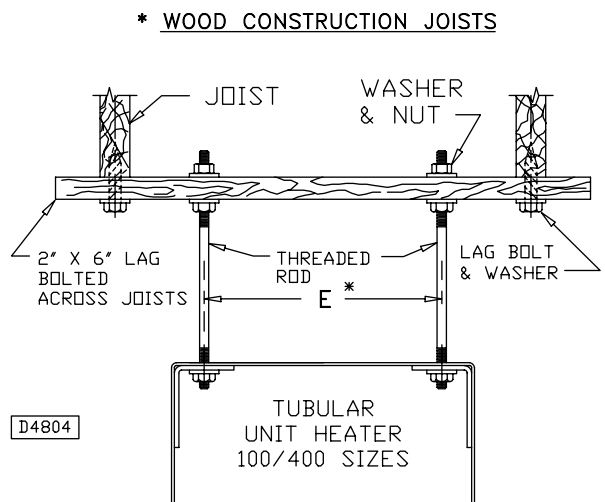

Figure 3B - Heater Mounting\*



\*All hanging hardware and wood is not included with the unit (To be field supplied).

Figure 3C



\* SEE TABLE 1 FOR DIMENSION E.

# GAS PIPING

**▲ WARNING** To avoid damage or possible personal injury, do not connect gas piping to this unit until a supply line pressure/leak test has been completed. Connecting the unit before completing the pressure/leak test may damage the unit gas valve and result in a fire hazard. Do not rely on a shut-off valve to isolate the unit while conducting gas pressure/leak tests. These valves may not be completely shut off, exposing the gas valve to excessive pressure and damage.

## PIPE SIZING

To provide adequate gas pressure to the gas unit heater, size the gas piping as follows:

- Find the cu. ft./hr. by using the following formula:

$$\text{Cu. ft./hr.} = \frac{\text{Input BTU/Hr.}}{1000}$$

- Refer to Table 3. Match "Length of Pipe in Feet" with appropriate "Gas Input - Cu. Ft./Hr." figure. This figure can then be matched to the pipe size at the top of the column.

Example:

It is determined that a 67 foot (20.4m) run of gas pipe is required to connect a 200 MBTU gas unit heater to a 1,000 BTU/cu ft. (0.29kW) natural gas supply.

$$\frac{200,000 \text{ BTU/Hr}}{1,000 \text{ BTU/cu. ft.}} = 200 \text{ Cu. ft./hr.}$$

Using Table 3, a 1 inch pipe is needed.

**NOTE: See General Safety Information section for English/Metric unit conversion factors.**

**NOTICE: If more than one unit heater is to be served by the same piping arrangement, the total cu. ft./hr. input and length of pipe must be considered.**

**NOTICE: If the gas unit heater is to be fired with LP gas, consult your local LP gas dealer for pipe size information.**

**NOTICE: HEATER INSTALLATION FOR USE WITH PROPANE (BOTTLED) GAS MUST BE MADE BY A QUALIFIED L.P. GAS DEALER OR INSTALLER. HE/SHE WILL INSURE THAT PROPER JOINT COMPOUNDS ARE USED FOR MAKING PIPE CONNECTIONS; THAT AIR IS PURGED FROM LINES; THAT A THOROUGH TEST IS MADE FOR LEAKS BEFORE OPERATING THE HEATER; AND THAT IT IS PROPERLY CONNECTED TO THE PROPANE GAS SUPPLY SYSTEM.**

Before any connection is made to the existing line supplying other gas appliances, contact the local gas company to make sure that the existing line is of adequate size to handle the combined load.

**Table 3 - Gas Pipe Size**

Maximum Capacity of Pipe in Cubic Feet of Gas per Hour (Cubic Meters per Hour) for Gas Pressures of 0.5 psig (3.5 kPa) or Less, and a Pressure Drop of 0.5 Inch Water Column (124.4 Pa)  
(Based on a 0.60 Specific Gravity Gas)

Nominal Iron Pipe Size	Internal Dia. in.	Length of Pipe, Feet (meters)													
		10 (3.0)	20 (6.1)	30 (9.1)	40 (12.2)	50 (15.2)	60 (18.3)	70 (21.3)	80 (24.4)	90 (27.4)	100 (30.5)	125 (38.1)	150 (45.7)	175 (53.3)	200 (61.0)
1/2	0.622	175 (4.96)	120 (3.40)	97 (2.75)	82 (2.32)	73 (2.07)	66 (1.87)	61 (1.73)	57 (1.61)	53 (1.50)	50 (1.42)	44 (1.25)	40 (1.13)	37 (1.05)	35 (0.99)
3/4	0.824	360 (10.2)	250 (7.08)	200 (5.66)	170 (4.81)	151 (4.28)	138 (3.91)	125 (3.54)	118 (3.34)	110 (3.11)	103 (2.92)	93 (2.63)	84 (2.38)	77 (2.18)	72 (2.04)
1	1.049	680 (19.3)	465 (13.2)	375 (10.6)	320 (9.06)	285 (8.07)	260 (7.36)	240 (6.80)	220 (6.23)	205 (5.80)	195 (5.52)	175 (4.96)	160 (4.53)	145 (4.11)	135 (3.82)
1 1/4	1.380	1400 (39.6)	950 (26.9)	770 (21.8)	660 (18.7)	580 (16.4)	530 (15.0)	490 (13.9)	460 (13.0)	430 (12.2)	400 (11.3)	360 (10.2)	325 (9.20)	300 (8.50)	280 (7.93)
1 1/2	1.610	2100 (59.5)	1460 (41.3)	1180 (33.4)	990 (28.0)	900 (25.5)	810 (22.9)	750 (21.2)	690 (19.5)	650 (18.4)	620 (17.6)	550 (15.6)	500 (14.2)	460 (13.0)	430 (12.2)
2	2.067	3950 (112)	2750 (77.9)	2200 (62.3)	1900 (53.8)	1680 (47.6)	1520 (43.0)	1400 (39.6)	1300 (36.8)	1220 (34.5)	1150 (32.6)	1020 (28.9)	950 (26.9)	850 (24.1)	800 (22.7)
2 1/2	2.469	6300 (178)	4350 (123)	3520 (99.7)	3000 (85.0)	2650 (75.0)	2400 (68.0)	2250 (63.7)	2050 (58.0)	1950 (55.2)	1850 (52.4)	1650 (46.7)	1500 (42.5)	1370 (38.8)	1280 (36.2)
3	3.068	11000 (311)	7700 (218)	6250 (177)	5300 (150)	4750 (135)	4300 (122)	3900 (110)	3700 (105)	3450 (97.7)	3250 (92.0)	2950 (83.5)	2650 (75.0)	2450 (69.4)	2280 (64.6)
4	4.026	23000 (651)	15800 (447)	12800 (362)	10900 (309)	9700 (275)	8800 (249)	8100 (229)	7500 (212)	7200 (204)	6700 (190)	6000 (170)	5500 (156)	5000 (142)	4600 (130)

1. Determine the required Cu. Ft./Hr. by dividing the input by 1000. For SI/Metric measurements: Convert BTU/Hr. to kilowatts. Multiply the units inputs (kW) by 0.0965 to determine Cu. Meters./Hr. 2. FOR NATURAL GAS: Select pipe size directly from the table. 3. FOR PROPANE GAS: Multiply the Cu. Ft./Hr. value by 0.633; then, use the table. 4. Refer to the metric conversion factors listed in the General Safety section for SI Unit measurement conversions.

## PIPE INSTALLATION

1. Install the gas piping in accordance with applicable local codes.
2. Check gas supply pressure. Each unit heater must be connected to a manifold pressure and a gas supply capable of supplying its full rated capacity as specified in Table 4. A field LP tank regulator must be used to limit the supply pressure to a maximum of 14 in. W.C. (3.5 kPa). All piping should be sized in accordance with ANSI Standard Z223.1-2002, (or the latest edition) National Fuel Gas Code; in Canada, according to CGA B149. See Tables 1 & 3 for correct gas piping size. If gas pressure is excessive on natural gas applications, install a pressure regulating valve in the line upstream from the main shutoff valve.
3. Adequately support the piping to prevent strain on the gas manifold and controls.
4. To prevent the mixing of moisture with gas, run the take-off piping from the top, or side, of the main.
5. Standard Unit Heaters, optional two-stage units are supplied with a combination valve which includes:
  - a. Manual "A" valve
  - b. Manual "B" valve
  - c. Solenoid valve
  - d. Pilot safety
  - e. Pressure regulator
 Pipe directly into the combination valve (see Figure 4).
6. A 1/8" N.P.T. plugged tapping, accessible for test gauge connection, must be installed immediately upstream of the gas supply connection to the appliance.
7. Provide a drip leg in the gas piping near the gas unit heater. A ground joint union and a manual gas shutoff valve should be installed ahead of the unit heater controls to permit servicing. The manual shutoff valve must be located external to the jacket. (See Figure 4)
8. Make certain that all connections have been adequately doped and tightened.

**▲ CAUTION** Do not over tighten the inlet gas piping into the valve. This may cause stresses that will crack the valve!

**NOTICE:** Use pipe joint sealant resistant to the action of liquefied petroleum gases regardless of gas conducted.

**▲ WARNING** Check all pipe joints for leakage using a soap solution or other approved method. Never use an open flame or severe personal injury or death may occur!

**Figure 4 - Pipe Installation, Standard Controls**

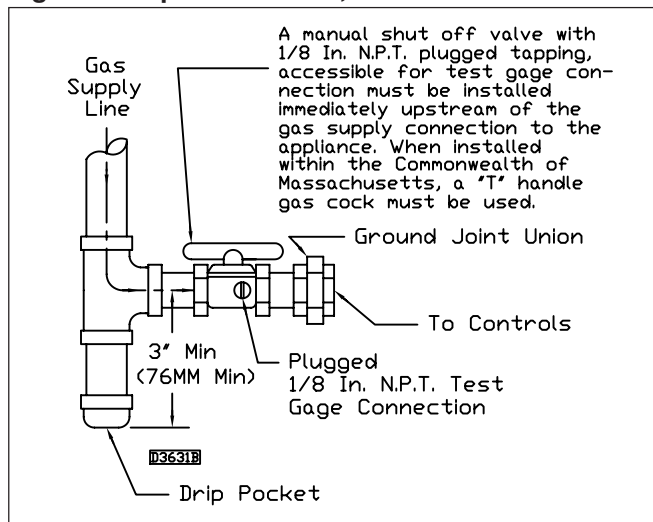

**▲ WARNING** Never use an open flame to detect gas leaks. Explosive conditions may exist which may result in personal injury or death!

The appliance and its individual shutoff valve must be disconnected from the gas supply piping system during any pressure testing of that system in excess of 1/2 psig (3.5 kPa).

The appliance must be isolated from the gas supply piping system by closing its individual manual shutoff valve during any pressure testing of the gas supply piping system at test pressures equal to or less than 1/2 psig (3.5 kPa).

**Table 4 - Gas Piping Requirements**

SINGLE STAGE GAS PIPING REQUIREMENTS*		
GasType	Natural Gas	Propane (LP) Gas
<b>Manifold Pressure</b>	3.5 in. W.C. (0.9 kPa)	10.0 in. W.C. (2.5 kPa)
<b>Supply Inlet Pressure</b>	14.0 in. W.C. Max. (3.5 kPa)	14.0 in. W.C. Max. (3.5 kPa)
	5.0 in. W.C. Min. (1.2 kPa)	11.0 in W.C. Min. (2.7 kPa)

\*For single stage application only at normal altitudes.



# ELECTRICAL CONNECTIONS



**▲ WARNING**  
**HAZARDOUS VOLTAGE!**  
**DISCONNECT ALL ELECTRIC POWER INCLUDING REMOTE DISCONNECTS BEFORE SERVICING. Failure to disconnect power before servicing can cause severe personal injury or death.**

Standard units are shipped for use on 115 volt, 60 hertz, single phase electric power. The motor name-plate and electrical rating of the transformer should be checked before energizing the unit heater electrical system. All external wiring must conform to the latest edition of ANSI/NFPA No. 70-2002, United States National Electrical Code, and applicable local codes; in Canada, to the Canadian Electrical Code, Part 1, CSA Standard C22.1.

**▲ CAUTION** Do not use any tools (i.e. screwdriver, pliers, etc.) across terminals to check for power. Use a voltmeter.

It is recommended that the electrical power supply to each unit heater be provided by a separate, fused, and permanently live electrical circuit. A disconnect switch of suitable electrical rating should be located as close to the gas valve and controls as possible. Each unit heater must be electrically grounded in accordance with the latest edition of the United States National Electrical Code, ANSI/NFPA No. 70-2002, or CSA Standard C22.1. Refer to Figures 5a, 5b, 5c, 5d, 5e, 5f and 5g.

## THERMOSTAT WIRING AND LOCATION:

**NOTICE: The thermostat must be mounted on a vertical, vibration-free surface, free from air currents, and in accordance with the furnished instructions.**

Mount the thermostat approximately 5 feet (1.5m) above the floor, in an area where it will be exposed to a free circulation of average temperature air. Always refer to the thermostat instructions, as well as our unit wiring diagram, and wire accordingly. Avoid mounting the thermostat in the following locations:

1. Cold Areas- Outside walls or areas where drafts may affect the operation of the control.
2. Hot Areas- Areas where the sun's rays, radiation, or warm air currents may affect the operation of the control.
3. Dead Areas- Areas where the air cannot circulate freely, such as behind doors or in corners.

**Figure 5a - Low-voltage T Thermostat Wiring Single Stage**

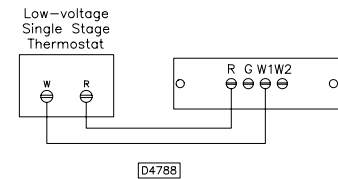

**Figure 5b - Low-voltage T Thermostat Wiring Two Stage**

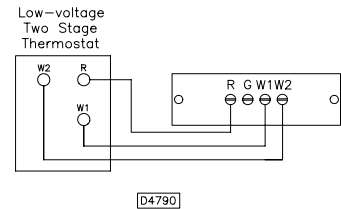

**Figure 5c - Honeywell T834H-1009 or T834H-1017 Thermostat Wiring**

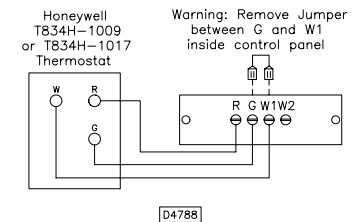

## THERMOSTAT HEAT ANTICIPATOR ADJUSTMENTS:

The initial heat anticipator setpoint should equal the thermostat's current amperage draw when the unit is firing. This setpoint should be measured for the best results. Use the recommended ranges for a guide. If further information is needed, consult your thermostat manufacturer's instructions.

Recommended heat anticipator setting ranges:

Gas Ignition Type	25 ft. (7.6m) T'stat Wiring	50 ft. (15.2m) T'stat Wiring
For Tubular Units:	0.85 to 0.90 A	0.90 to 1.1 A Max. Setting on T'stat

**FAN TIME DELAY CONTROL:** Leads from the fan time delay control are factory wired to the junction box. The fan time delay control is a time delay relay (approximately 45 seconds ON, 65 seconds OFF). The fan time delay control is rated at 17 amps.

**NOTICE: The start-up fan delay should not exceed 90 seconds from a cold start.**

**IMPORTANT: For all wiring connections, refer to the wiring diagram shipped with your unit (either affixed to the side jacket or enclosed in the installation instructions envelope). Should any original wire supplied with the heater have to be replaced, it must be replaced with wiring material having a temperature rating of at least 105° C.**

**Should any high limit wires have to be replaced, they must be replaced with wiring material having a temperature rating of 200° C minimum.**

# ELECTRICAL CONNECTIONS (continued)

**Figure 5d & 5e - Tubular Units Equipped with Hot Surface Pilot (Single Stage):  
100/400 Unit Sizes with Natural Gas and Propane (LP) Gas**

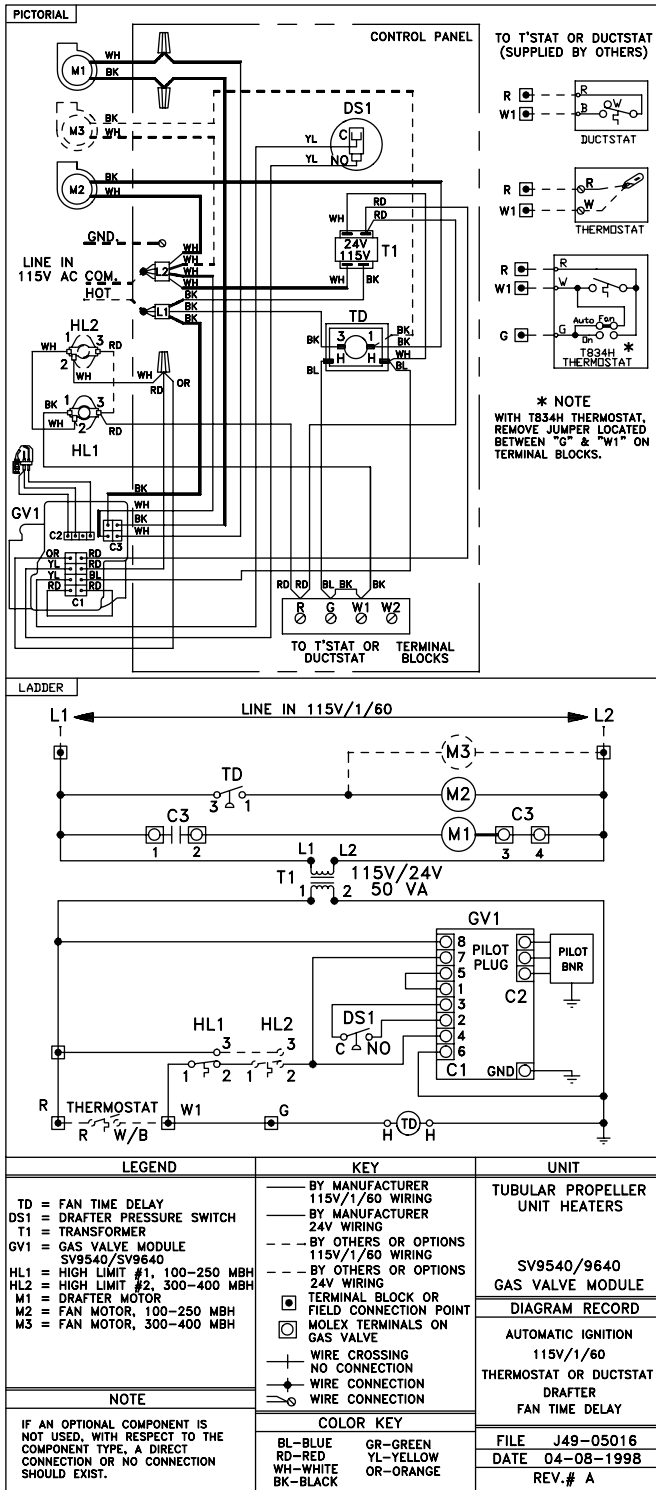

**Figure 5d  
(Primary)**

[HWSV9540/SV9640  
Hot Surface Ignition Gas Controls]

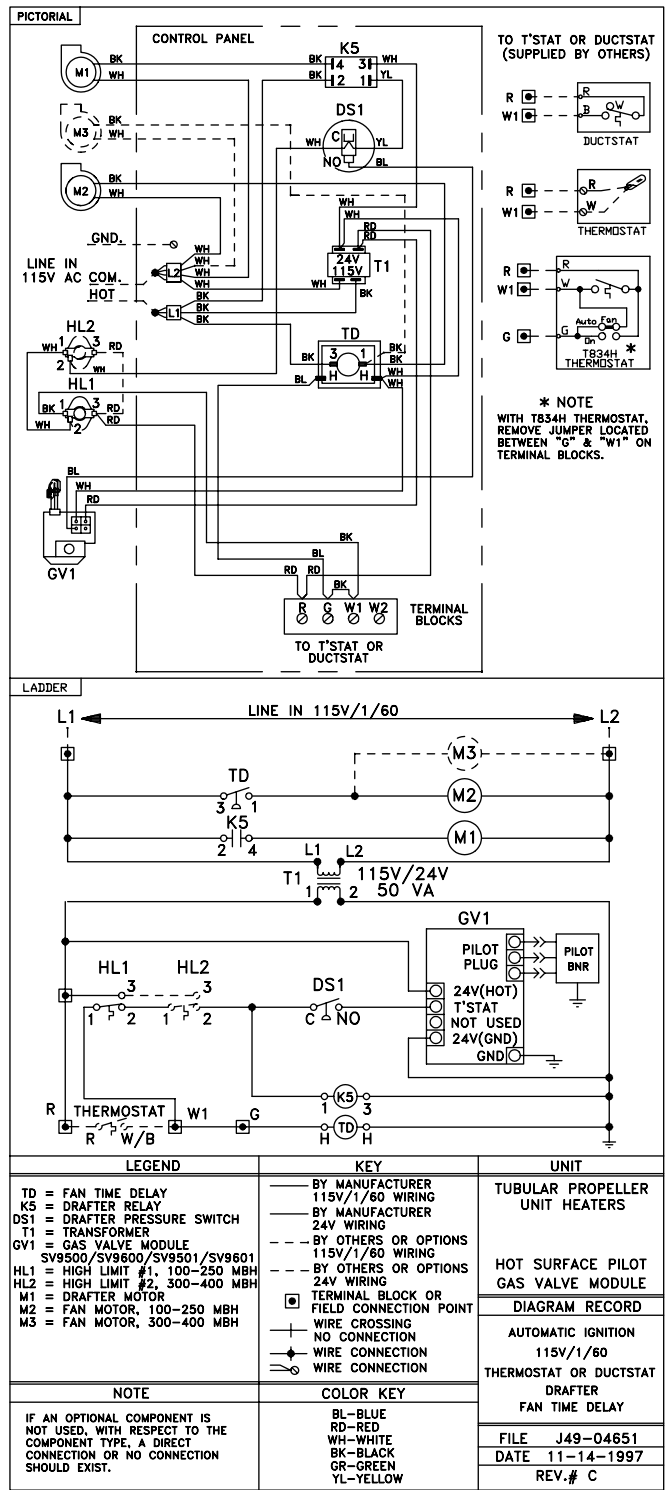
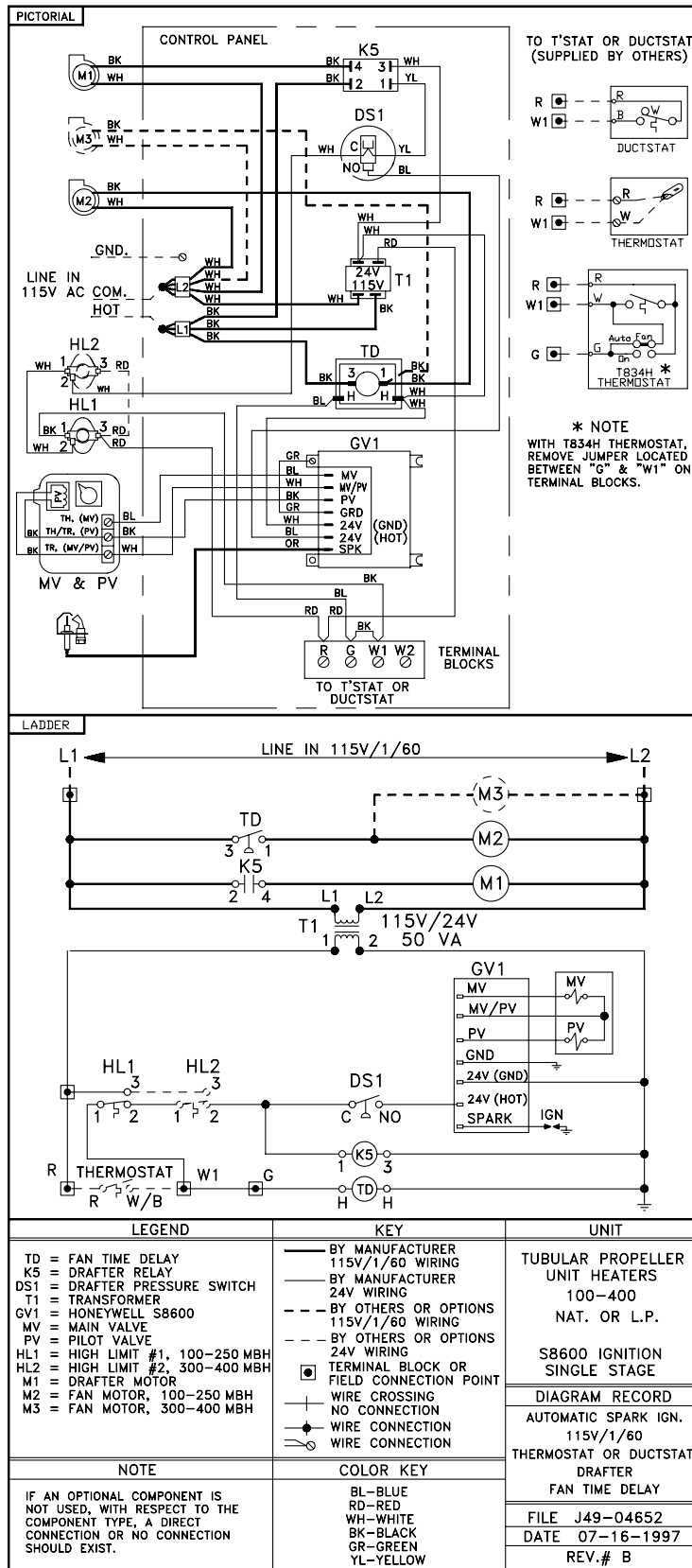

**Figure 5e  
(Alternate)**

[HWSV9500/SV9600/SV9501/SV9601  
Hot Surface Ignition Gas Controls]

# ELECTRICAL CONNECTIONS (continued)

Figure 5f - Tubular Units Equipped with S8600 (Single Stage) Ignition:  
Optional for Tubular 100/400 Unit Sizes with Natural Gas and Propane (LP) Gas





# VENTING

ANSI now organizes vented appliances into four categories.

## Venting Categories

	Non Condensing	Condensing
Negative Vent Pressure	I	II
Positive Vent Pressure	III	IV

### Category I

Includes non-condensing appliances with negative vent pressure, like the traditional atmospheric unit heater.

### Category II

Groups condensing appliances with negative vent pressure.

### Category III

Appliances are non-condensing and operate with a positive vent pressure.

### Category IV

Covers condensing appliances with positive vent pressure.

**NOTICE: Category II and IV do not apply to equipment specified within this manual.**

All unit heaters must be vented! All Venting installations shall be in accordance with the latest edition of Part 7, Venting of Equipment of the National Fuel Gas Code, ANSI Z223.1, or applicable provisions of local building codes. Refer to page 15 for Canadian installations. Refer to Figures 6, 7, 8A, 8B, 9A and 9B.

**▲ WARNING CARBON MONOXIDE!** Your venting system must not be blocked by any snow, snow drifts, or any foreign matter. Inspect your venting system to ensure adequate ventilation exists at all times! Failure to heed these warnings could result in Carbon Monoxide Poisoning (symptoms include grogginess, lethargy, inappropriate tiredness, or flu-like symptoms).

## VERTICALLY VENTED UNIT HEATERS (CATEGORY I)

Observe the following precautions when venting the unit:

- Use flue pipe of the same size as the flue connections on the gas unit heater (See Table #1). All heaters should be vented with UL Listed Type B vent, a factory built chimney, or a lined brick and mortar chimney that has been constructed in accordance with the National Building Code.
- Provide as long a vertical run of flue pipe at the gas unit heater as possible. A minimum of five feet (1.5m) of vertical flue is required. The top of the vent pipe should extend at least two feet (0.61m) above the highest point on the roof. Install a weather cap over the vent opening.
- Slope horizontal runs upward from the gas unit heater at least 1/4-inch per foot (21mm/m). Horizontal runs should not exceed 75% of the vertical height of the vent pipe, or chimney, above the flue pipe connection, up to a maximum length of 10 feet (3m). Horizontal portions of the venting system shall be supported at maximum intervals of four feet (1.2m). (See Figure 6)
- Use as few elbows as possible.
- Tape flue pipe joints with fireproof paper or material.
- Avoid running vent pipe through unheated spaces.
- When this cannot be avoided, insulate the pipe to prevent condensation of moisture on the walls of the pipe.
- Do not damper the flue piping. Failure to open such a damper prior to operating the gas unit heater will result in the spillage of flue gas into the occupied space.
- Avoid installing units in areas under negative pressure due to large exhaust fans or air conditioning. When required, a flue vent fan should be installed in accordance with the instructions included with the fan.
- Vent connectors serving Category I and Category II heaters shall not be connected into any portion of mechanical draft systems operating under positive pressure.

## HORIZONTALLY VENTED UNIT HEATERS (CATEGORY III)

Horizontal venting arrangements are designed to be used with single wall vent pipe. Horizontal venting arrangements must terminate external to the building using either single wall or double wall (Type B) vent. If single wall vent pipe is used, it must be constructed of 26 gauge galvanized steel or a material of equivalent durability and corrosion resistance for the vent system. For installations in Canada, use pipe constructed from .025 inch thick aluminum or .018 inch thick stainless steel. See Figures 7, 8A and 9A for special installation requirements regarding these venting conditions.

**▲ WARNING** Do not use Type B (double wall) vent internally within the building on horizontally vented power vented units!

If double wall venting is used, components which are UL Listed and approved for Category III positive pressure venting systems MUST be used.

A Breidert Type L, Fields Starkap, or equivalent vent cap must be supplied by the customer for each power vented unit. The vent pipe diameter MUST be as specified in Table 1 ("D" Dia. Flue Opening). All unit sizes are factory equipped with the required flue size collar; attach in place (if not mounted to outlet); refer to included vent collar instruction sheet for additional requirements.

Vent Systems - Termination Clearance Requirements	
Structure	Minimum Clearances for Termination Locations
Door, window or any gravity air inlet	4 feet below
	4 feet horizontally
	1 foot above
Forced air inlet within 10 ft.	3 feet above
Adjoining building or parapet	6 feet
Adjacent public walkways	7 feet above grade

The venting system for these appliances shall terminate at least four feet (1.2m) below, four feet (1.2m) horizontal from, or one foot (0.3m) above any door, window, or gravity vent air inlet into the building.

The vent terminal must be at least 12 inches (305mm) from the exterior of the wall that it passes through to prevent degradation of the building material by flue gases.

The vent terminal must be at least 3 feet (1m) above grade, or in snow areas, at least three feet above the snow line to prevent blockage by snow.

Through the wall vent for these appliances shall NOT terminate over public walkways, or over an area where the condensate or vapor could create a nuisance or hazard or could be detrimental to the operation of regulators, relief valves, or other equipment.

The vent pipe equivalent length must not exceed 50 feet (15.2m). Equivalent length is the total length of straight sections PLUS 15 feet (4.6m) for each 90 elbow and 8 feet (2.44m) for each 45 elbow.

Maintain 6 inches (152mm) between the vent pipe and combustible materials.

The vent terminal must be installed with a minimum horizontal clearance of four feet (1.2m) from electric meters, gas meters, regulators, and relief equipment.

Seal all vent pipe joints and seams to prevent leakage. Use General Electric RTV-108, Dow-Corning RTV-732 silicone sealant; or 3M #425 aluminum foil tape. The vent air system must be installed to prevent collection of condensate. Pitch horizontal pipes downward 1/4 inch per foot (21mm per meter) toward the outlet for condensate drainage.

Horizontal portions of the venting systems shall be supported at maximum intervals of four feet (1.2m) to prevent sagging (in Canada, support at 3 feet (1m) maximum intervals).

Insulate single wall vent pipe exposed to cold air or running through unheated areas.

**Each unit must have an individual vent pipe and vent terminal!** Each unit MUST NOT be connected to other vent systems or to a chimney.

## VENTING (continued)

**Figure 6 - Vertically Vented Tubular Unit Heater – Category I**

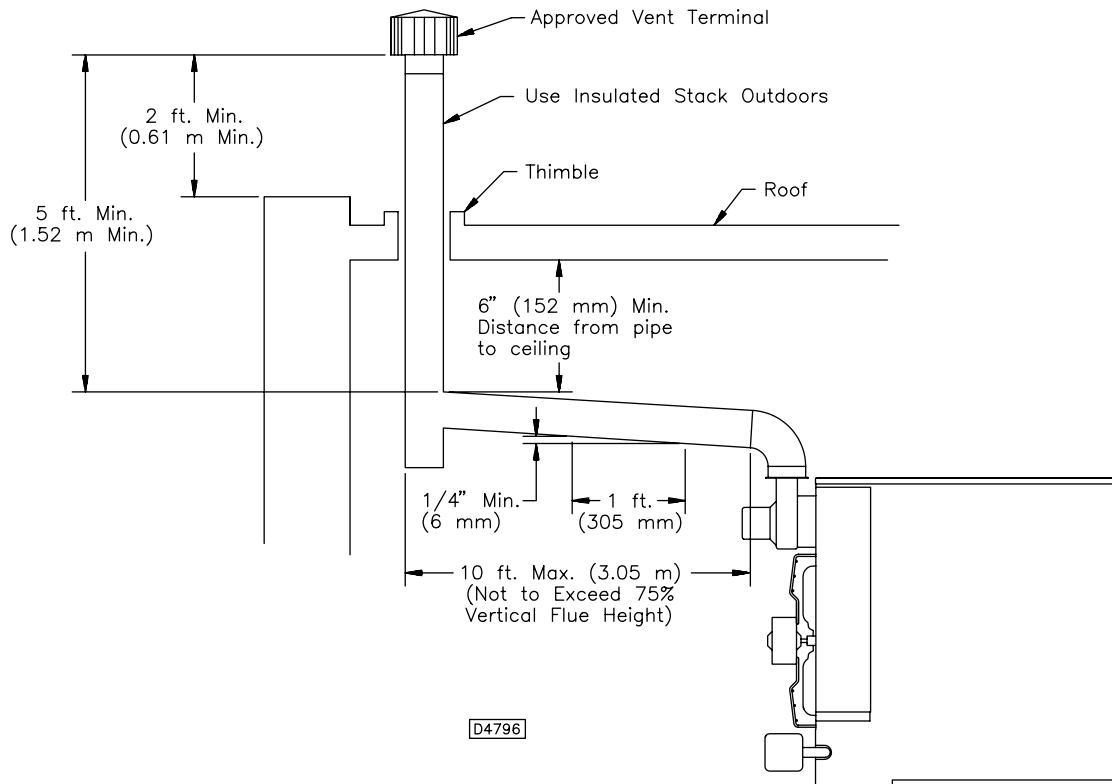

**Figure 7 - Horizontally Vented Tubular Unit Heater – Category III**

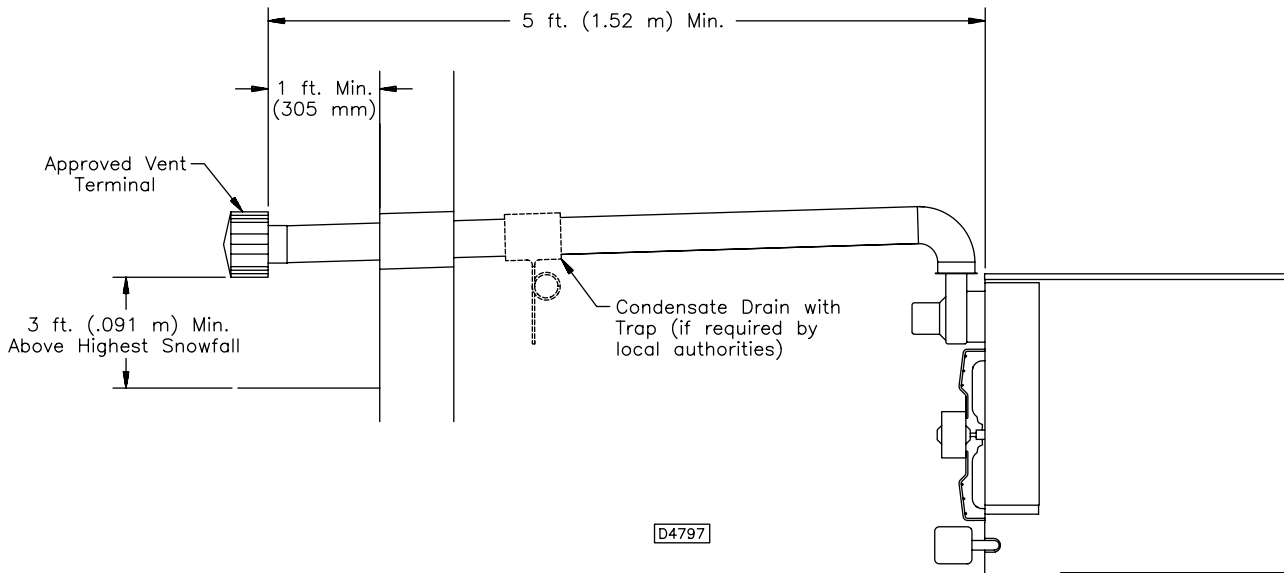

### ADDITIONAL REQUIREMENT FOR CANADIAN INSTALLATIONS

REFER TO SPECIFICATION TABLE AND INSTALLATION MANUAL FOR PROPER USAGE.

\* The following instructions apply to Canadian installations in addition to installation and operating instructions.

1. Installation must conform with local building codes, or in the absence of local codes, with current CGA B149.1, Installation Codes for Natural Gas Burning Appliances and Equipment, or CGA B149.2, Installation Codes for Propane Gas Burning Appliances and Equipment.
2. Any reference to U. S. standards or codes in these instructions are to be ignored, and the applicable Canadian standards or codes applied.

# VENTING (continued)

Figure 8A

## HORIZONTAL ARRANGEMENT SINGLE WALL VENT SYSTEM TO SINGLE WALL TERMINATION

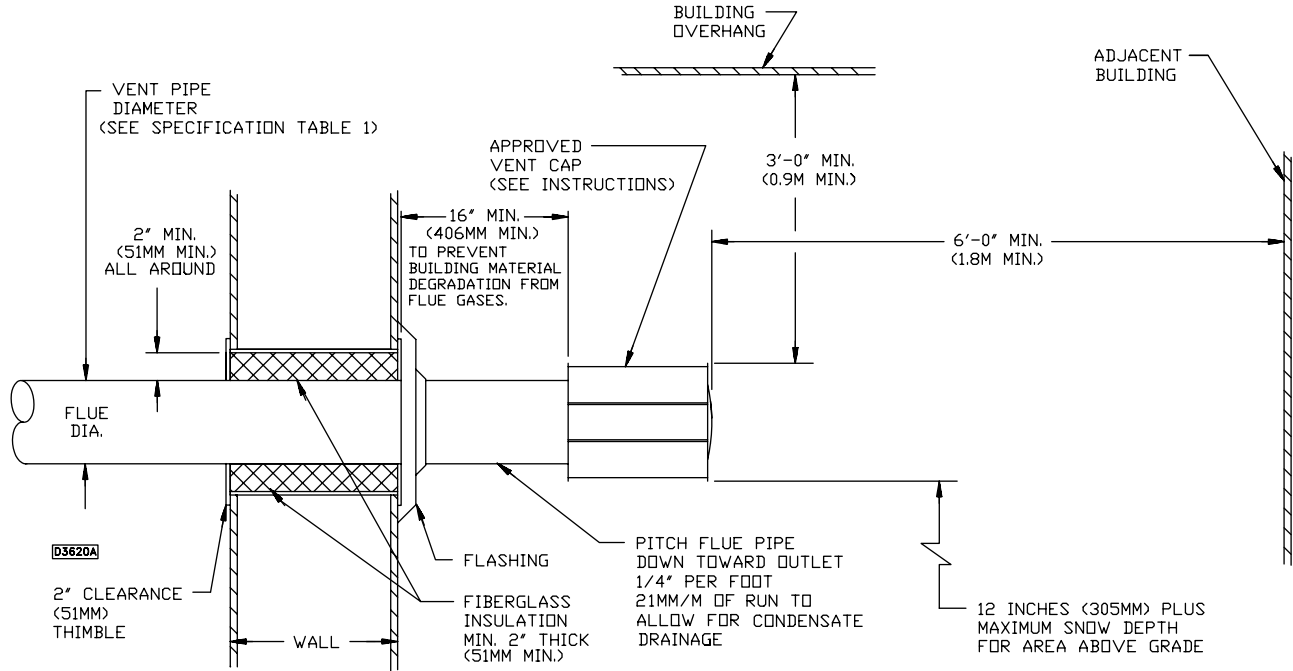
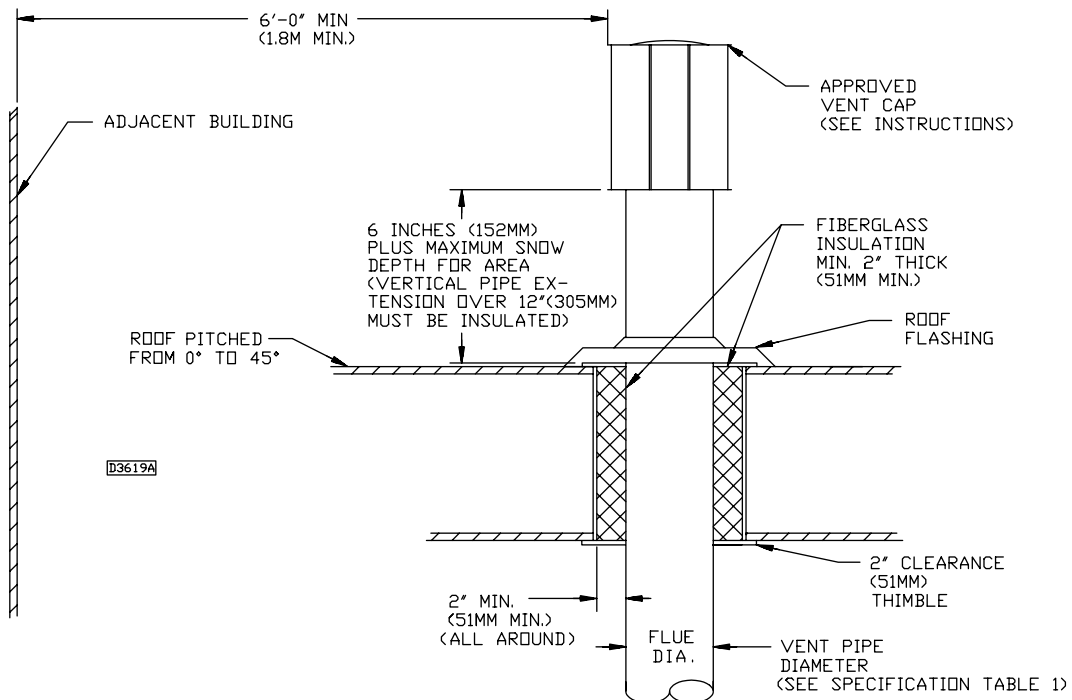

Figure 8B

## VERTICAL ARRANGEMENT SINGLE WALL VENT SYSTEM TO SINGLE WALL TERMINATION





# VENTING (continued)

Figure 9A

## HORIZONTAL ARRANGEMENT

SINGLE WALL VENT SYSTEM TO DOUBLE WALL TERMINATION

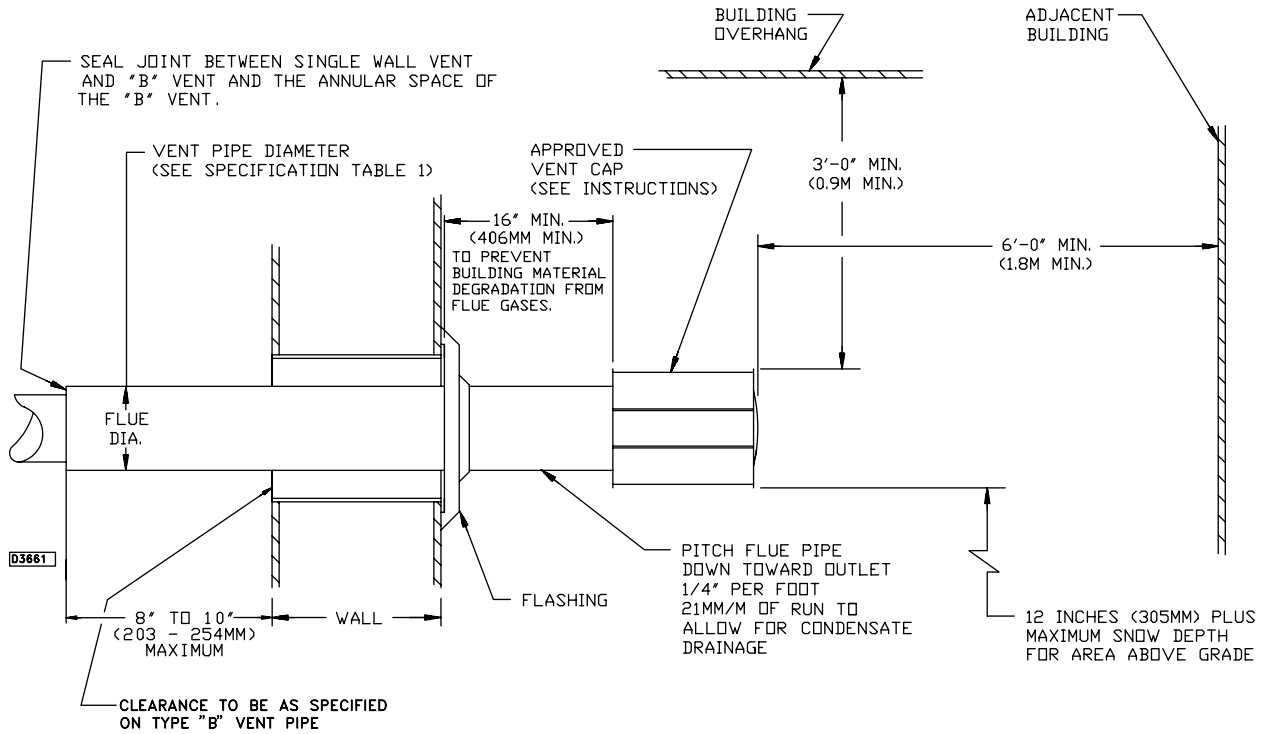
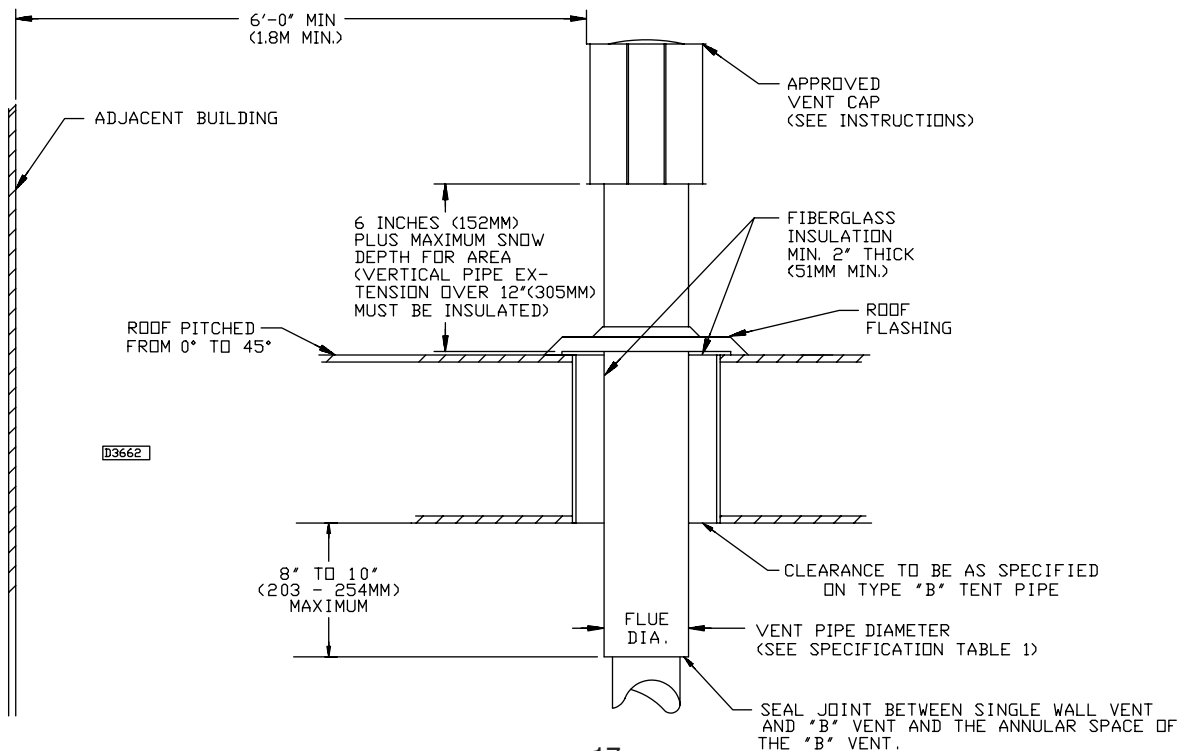

Figure 9B

## VERTICAL ARRANGEMENT

SINGLE WALL VENT SYSTEM TO DOUBLE WALL TERMINATION



# OPERATION

## POWER VENTED PROPELLER UNITS

### INTERMITTENT PILOT IGNITION

#### EXPLANATION OF CONTROLS (See Figure 10):

1. The unit heater is equipped with a power venter system consisting of a power venter motor and blower, pressure switch, and sealed flue collector in place of the conventional draft diverter.
2. The power venter motor is energized by the room thermostat on a call for heat. The pressure switch measures the flow through the vent system and energizes the indirect ignition system when the flow is correct.

**▲ WARNING** The pressure switch **MUST NOT** be bypassed. The unit **MUST NOT** be fired unless the power venter is operating. An unsafe condition could result.

3. The indirect ignition system consists of an ignition control module, a dual combination gas valve, and a pilot burner. When the pressure switch closes, the pilot valves opens and the pilot burner is ignited by either a spark or hot surface element. When flame sensing circuit senses that the pilot flame is established, the main gas valve is opened to supply gas to the main burners. When the thermostat is satisfied, the vent system is deenergized and both valves are closed to stop all flow of gas to the unit.
4. The limit switch interrupts the flow of electric current to the main gas valve in case the heater becomes overheated.
5. The fan switch delays the operation of the fan until the heater is warmed, then keeps the fan running after the gas has been turned off until the useful heat has been removed. **The startup fan delay must not exceed 90 seconds from a cold start.**
6. The wall thermostat (supplied optionally) is a temperature sensitive switch which operates the vent system and the ignition system to control the temperature of the space being heated. It must be mounted on a vibration free, vertical surface away from air currents, in accordance with the instructions furnished with the thermostat (also refer to Electrical Section).

#### START-UP (Also refer to lighting instruction plate equipped on the unit)

1. Open the manual valve supplying gas to the unit heater, and with the union connection loose, purge air from the gas line. Tighten the union and check for gas leaks.

**▲ WARNING** Never use an open flame to detect gas leaks. Explosive conditions may exist which could result in personal injury or death.

**▲ WARNING** Before attempting to light or relight pilot, wait 5 minutes to allow gas which may have accumulated in the burner compartment to escape.

2. Open the manual valve on the unit heater.
3. Turn ON electrical power.
4. The unit should be under the control of the thermostat. Turn the thermostat to the highest point and determine that the power venter motor starts, and the pilot and main burners ignite. Turn the thermostat to the lowest point and determine that the power venter motor shuts off and the pilot and main burners are extinguished.
5. If pilot adjustment is required, remove the pilot adjustment seal cap and adjust the pilot screw to obtain proper flame. Clockwise rotation decreases pilot flame size. Replace the cap.
6. Turn the thermostat to the desired position.
7. See Gas Input Rate and Adjustments sections.

#### SHUT DOWN

1. Turn the valve selector knob to the "OFF" position.
2. Turn off the electricity.
3. To relight, follow the "start-up" instructions.

See Figure 10 for parts/identification.

**Figure 10**  
**Manifold**  
**Assembly**

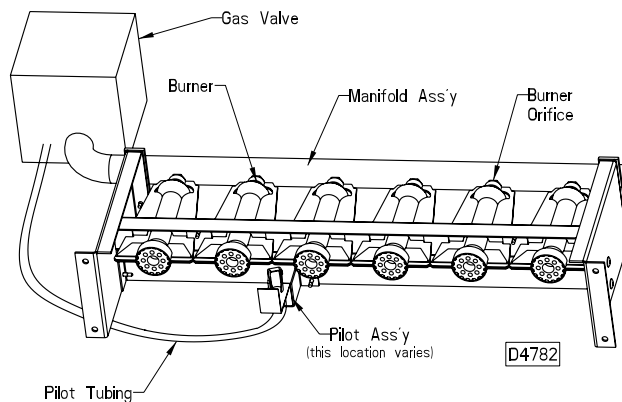

# PRIMARY AIR SHUTTER ADJUSTMENT

Primary air adjustment is made at the factory. No field adjustments are necessary.

## GAS INPUT RATE

Check the gas input rate as follows (Refer to General Safety Information section for metric conversions).

**▲ CAUTION** Never overfire the unit heater, as this may cause unsatisfactory operation, or shorten the life of the heater.

1. Turn off all gas appliances that use gas through the same meter as the unit heater.
2. Turn the gas on to the unit heater.
3. Clock the time in seconds required to burn 1 cubic foot of gas by checking the gas meter.
4. Insert the time required to burn one cubic foot of gas into the following formula and compute the input rate.

$$\frac{3600 \text{ (Sec. per Hr.)} \times \text{BTU/Cu. Ft.}}{\text{Time (Sec.)}} = \text{Input Rate}$$

For example:

Assume the BTU content of one cubic foot of gas is 1000, and that it takes 18 seconds to burn one cubic foot of gas.

$$\frac{3600 \times 1000}{18} = 200,000$$

**NOTICE:** If the computation exceeds, or is less than 95% of the gas BTU/hr. input rating (see Table 2), adjust the gas pressure.

Adjust the gas pressure as follows:

1. NATURAL GAS: Best results are obtained when the unit heater is operating at its full rated input with the manifold pressure of 3.5 inches W.C. (0.9 kPa). Adjustment of the pressure regulator is not normally necessary since it is preset at the factory. However, field adjustment may be made as follows:
  - a. Attach manometer at the pressure tap plug adjacent to the control outlet.
  - b. Remove the regulator adjustment screw cap, located on the combination gas valve.
  - c. With a small screwdriver, rotate the adjustment screw counterclockwise to decrease pressure, or clockwise to increase pressure.
  - d. Replace regulator adjustment screw cap.

2. PROPANE GAS: An exact manifold pressure of 10.0 inches W.C. (2.5 kPa) must be maintained for proper operation of the unit heater. If the unit is equipped with a pressure regulator on the combination gas valve, follow steps "a" through "d" above. If the unit is not so equipped, the propane gas supply system pressure must be regulated to attain this manifold operating pressure.
3. The adjusted manifold pressure should not vary more than 10% from pressure specified in Table 5.

**Table 5 - Main Burner Orifice Schedule\***

* INPUT IN 1000 BTU	TYPE OF GAS	NATURAL	PROPANE	NO. OF BURNER ORIFICES
	HEATING VALUE	1075 BTU/Ft <sup>3</sup> (40.1 MJ/m <sup>3</sup> )	2500 BTU/Ft <sup>3</sup> (93.1 MJ/m <sup>3</sup> )	
	MANIFOLD PRESSURE	3.5" W.C. (0.87kPa)	10" W.C. (2.49 kPa)	
100	FT <sup>3</sup> /HR	93	40	4
	ORIFICE DRILL	42	53	
125	FT <sup>3</sup> /HR	116	50	5
	ORIFICE DRILL	42	53	
150	FT <sup>3</sup> /HR	140	60	6
	ORIFICE DRILL	42	53	
175	FT <sup>3</sup> /HR	163	70	7
	ORIFICE DRILL	42	53	
200	FT <sup>3</sup> /HR	186	80	8
	ORIFICE DRILL	42	53	
250	FT <sup>3</sup> /HR	233	100	10
	ORIFICE DRILL	42	53	
300	FT <sup>3</sup> /HR	280	120	12
	ORIFICE DRILL	42	53	
350	FT <sup>3</sup> /HR	326	140	14
	ORIFICE DRILL	42	53	
400	FT <sup>3</sup> /HR	372	160	16
	ORIFICE DRILL	42	53	

\*This schedule is for units at operating at normal altitudes of 2000 ft. (610m) or less.

When installed in Canada, any references to deration at altitudes in excess of 2000 ft. (610m) are to be ignored. At altitudes of 2000 to 4500 ft. (610 to 1372m), the unit heaters must be orificed to 90% of the normal altitude rating, and be so marked in accordance with CSA certification.

**TUBULAR UNIT HEATER  
HIGH ALTITUDE DERATION**

This Tubular Unit Heater has been manufactured utilizing standard burner orifices and a normal manifold pressure setting as per the specifications shown on your unit rating plate.

All unit deration must be done through field adjustments by a qualified technician. Once the proper adjustments are made in the field, attach label #J17-06459 to the unit, and record adjusted manifold pressure, altitude of the unit installation and the technician's name and date on the label using a permanent marker.

Refer to Installation Instruction section on Adjustments-Gas Input Rate for adjusting the manifold pressure.

**Table 5A**

Altitude (Feet)	NATURAL GAS		PROPANE (LP) GAS	
	Heating* Value BTU/Cu. ft.	Manifold Pressure (In. W.C.)	Heating* Value BTU/Cu. ft.	Manifold Pressure (In. W.C.)
2,000	948	3.5	2,278	8.6
2,500	931	3.5	2,237	8.5
3,000	914	3.3	2,196	8.4
3,500	897	3.2	2,156	8.4
4,000	881	3.2	2,116	8.3
4,500	865	3.2	2,077	8.2
5,000	849	3.1	2,039	8.1
5,500	833	3.1	2,000	8.0
6,000	818	3.0	1,964	7.9
6,500	802	3.0	1,927	7.7
7,000	787	2.9	1,891	7.6
7,500	771	2.9	1,853	7.5
8,000	756	2.8	1,817	7.4
8,500	741	2.8	1,781	7.2
9,000	726	2.7	1,745	7.1
9,500	711	2.7	1,709	6.9
10,000	696	2.6	1,673	6.8

\*Notes:

1. Consult local utility for actual heating value.
2. Tables based on heating value of 1,050 BTU/Cu. ft. at sea level.

**Table 6 - Tubular Propeller Troubleshooting Guide**

<b>SYMPTOMS</b>	<b>POSSIBLE CAUSE(S)</b>	<b>CORRECTIVE ACTION</b>
A. Flame lifting from burner ports.	<ol style="list-style-type: none"> <li>1. Pressure regulator set too high.</li> <li>2. Defective Regulator.</li> <li>3. Burner orifice too large.</li> </ol>	<ol style="list-style-type: none"> <li>1. Reset manifold pressure. Refer to "Operation".</li> <li>2. Replace regulator section of combination gas valve or complete valve.</li> <li>3. Check with local gas supplier for proper orifice size and replace. Refer to "Operation".</li> </ol>
B. Flame pops back.	<ol style="list-style-type: none"> <li>1. Burner orifice too small.</li> </ol>	<ol style="list-style-type: none"> <li>1. Check with local gas supplier for proper orifice size and replace. Refer to "Operation".</li> </ol>
C. Noisy flame.	<ol style="list-style-type: none"> <li>1. Noisy pilot</li> <li>3. Irregular orifice causing whistle or resonance.</li> <li>3. Excessive gas input.</li> </ol>	<ol style="list-style-type: none"> <li>1. Reduce pilot gas. Refer to "Operation".</li> <li>2. Replace orifice.</li> <li>3. Reset manifold pressure. Refer to "Operation"; Replace regulator section of combination gas valve or complete valve; Check with local gas supplier for proper orifice size and replace. Refer to "Operation".</li> </ol>
D. Yellow tip flame (some yellow tipping on propane gas is permissible).	<ol style="list-style-type: none"> <li>1. Clogged main burner ports.</li> <li>2. Misaligned orifices.</li> <li>3. Insufficient combustion air.</li> </ol>	<ol style="list-style-type: none"> <li>1. Clean main burner ports.</li> <li>2. Replace manifold assembly.</li> <li>3. Clean combustion air inlet openings in bottom panel, see "Installation".</li> </ol>
E. Floating flame.	<ol style="list-style-type: none"> <li>1. Blocked venting.</li> <li>2. Insufficient combustion air.</li> <li>3. Blocked heat exchanger.</li> <li>4. Air leak into combustion chamber or draft hood.</li> </ol>	<ol style="list-style-type: none"> <li>1. Clean flue. Refer to "Installation".</li> <li>2. Clean combustion air inlet openings in bottom panel, see "Installation".</li> <li>3. Clean heater.</li> <li>4. Determine cause and repair accordingly.</li> </ol>
<b>F. Gas Odor.</b>	<ol style="list-style-type: none"> <li><b>1. Shut off gas supply immediately!</b></li> <li>2. Blocked heat exchanger.</li> <li>3. Drafts around heater.</li> <li>4. Negative Pressure in building.</li> <li>5. Blocked draft hood.</li> </ol>	<ol style="list-style-type: none"> <li><b>1. Inspect all gas piping and repair.</b></li> <li>2. Clean heat exchanger/flue.</li> <li>3. Eliminate drafts. Refer to "Installation".</li> <li>4. See "Installation".</li> <li>5. Clean flue collector.</li> </ol>
G. Delayed ignition.	<ol style="list-style-type: none"> <li>1. Main burner ports clogged near pilot.</li> <li>2. Pressure regulator set too low.</li> <li>3. Pilot decreases in size when main burners come on.</li> <li>4. Pilot flame too small.</li> <li>5. Drafts around heater.</li> <li>6. Improper venting.</li> </ol>	<ol style="list-style-type: none"> <li>1. Clean main burner ports.</li> <li>2. Reset manifold pressure. Refer to "Operation".</li> <li>3. Supply piping is inadequately sized. Refer to "Installation".</li> <li>4. Clean pilot orifice. Refer to "Operation".</li> <li>5. Eliminate drafts. Refer to "Installation".</li> <li>6. Refer to "Installation".</li> </ol>
H. Failure to ignite.	<ol style="list-style-type: none"> <li>1. Main gas off.</li> <li>2. Lack of power at unit.</li> <li>3. Thermostat not calling for heat.</li> <li>4. Defective limit switch.</li> <li>5. Improper thermostat or transformer wiring at gas valve.</li> <li>6. Defective gas valve.</li> <li>7. Defective thermostat</li> <li>8. Defective transformer.</li> <li>9. Loose wiring.</li> <li>10. Defective ignition control.</li> </ol>	<ol style="list-style-type: none"> <li>1. Open all manual gas valves.</li> <li>2. Replace fuse or turn on power supply.</li> <li>3. Turn up thermostat</li> <li>4. Check limit switch with continuity tester. If open, replace limit switch.</li> <li>5. Check wiring per diagrams.</li> <li>6. Replace gas valve.</li> <li>7. Check thermostat and replace if defective.</li> <li>8. Replace, if necessary. Also see W, X &amp; Y symptoms.</li> <li>9. Check and tighten all wiring connections per diagrams.</li> <li>10. Replace, if necessary. Also see W, X, &amp; y symptoms.</li> </ol>
J. Condensation of water vapor.	<ol style="list-style-type: none"> <li>1. Improper venting.</li> </ol>	<ol style="list-style-type: none"> <li>1. Refer to "Installation and Venting".</li> </ol>
K. Burner won't turn off.	<ol style="list-style-type: none"> <li>1. Poor thermostat location.</li> <li>2. Defective thermostat</li> <li>3. Improper thermostat or transformer wiring at gas valve.</li> <li>4. Short circuit.</li> <li>5. Defective or sticking gas valve.</li> <li>6. Excessive gas supply pressure.</li> </ol>	<ol style="list-style-type: none"> <li>1. Relocate thermostat away from drafts.</li> <li>2. Replace thermostat.</li> <li>3. Check wiring per diagrams.</li> <li>4. Check operation at valve. Look for short (such as staples piercing thermostat wiring), and correct.</li> <li>5. Replace gas valve.</li> <li>6. Refer to "Operation".</li> </ol>

**Table 6 - Tubular Propeller Troubleshooting Guide (continued)**

SYMPTOMS	POSSIBLE CAUSE(S)	CORRECTIVE ACTION
L. Rapid burner cycling.	<ol style="list-style-type: none"> <li>1. Loose wire connections at gas valve or thermostat.</li> <li>2. Excessive thermostat heat anticipation.</li> <li>3. Unit cycling on high limit.</li> <li>4. Poor thermostat location.</li> <li>5. Draft on Pilot.</li> <li>6. Defective ignitor control.</li> </ol>	<ol style="list-style-type: none"> <li>1. Tighten all electrical connections.</li> <li>2. Adjust thermostat heat anticipator for longer cycles. Refer to "Operation".</li> <li>3. Check for proper air supply across heat exchanger.</li> <li>4. Relocate thermostat. (Do not mount thermostat on unit).</li> <li>5. Eliminate drafts. Refer to "Installation".</li> <li>6. Replace ignitor.</li> </ol>
M. Noisy power ventor.	<ol style="list-style-type: none"> <li>1. Power ventor wheel loose.</li> <li>2. Power ventor wheel dirty.</li> <li>3. Power ventor wheel rubbing housing.</li> <li>4. Bearings are dry.</li> </ol>	<ol style="list-style-type: none"> <li>1. Replace or tighten.</li> <li>2. Clean power ventor wheel.</li> <li>3. Realign power ventor wheel.</li> <li>4. Oil bearings on power ventor motor. (Refer to label on motor).</li> </ol>
N. Pilot will not light or will not stay lit.	<ol style="list-style-type: none"> <li>1. Main gas valve off.</li> <li>2. Pilot adjustment screw turned too low on combination main gas valve.</li> <li>3. Air in gas line.</li> <li>4. Incorrect lighting procedure.</li> <li>5. Dirt in pilot orifice.</li> <li>6. Extremely high or low gas pressure.</li> <li>7. Defective spark cable.</li> <li>8. Drafts around unit.</li> <li>9. Pilot valve not opening (faulty wiring).</li> <li>10. Pilot element not glowing or no spark (faulty wiring).</li> <li>11. Defective gas valve.</li> </ol>	<ol style="list-style-type: none"> <li>1. Open all manual gas valves.</li> <li>2. Increase size of pilot flame. Refer to "Operation".</li> <li>3. Purge air from gas line.</li> <li>4. Follow lighting instruction label adjacent to gas valve.</li> <li>5. Remove pilot orifice. Clean with compressed air or solvent. (Do not ream).</li> <li>6. Refer to "Operation".</li> <li>7. Check thermocouple connection, and replace if defective.</li> <li>8. Eliminate drafts. Refer to "Installation".</li> <li>9. Inspect and correct wiring.</li> <li>10. Inspect and correct ignition system wiring. See symptoms W, X, &amp; Y.</li> <li>11. Replace gas valve.</li> </ol>
O. Fan will not run.	<ol style="list-style-type: none"> <li>1. Loose wiring.</li> <li>2. Defective motor overload protector or defective motor.</li> <li>3. Defective fan switch.</li> </ol>	<ol style="list-style-type: none"> <li>1. Check and tighten all wiring connections per diagrams. See "Electrical Connections".</li> <li>2. Replace motor.</li> <li>3. Check for 24V across H terminals on fan time delay switch. If 24V is present, jumper terminals numbered 1 and 3. If motor runs, the fan switch is defective and must be replaced. If 24V is not present, check wiring per diagrams.</li> </ol>
P. Fan motor turns on and off while burner is operating.	<ol style="list-style-type: none"> <li>1. Fan switch heater element improperly wired.</li> <li>2. Defective fan switch.</li> <li>3. Motor protector cycling ON and OFF.</li> <li>4. Motor not properly oiled.</li> </ol>	<ol style="list-style-type: none"> <li>1. Be sure fan switch heater terminals are connected per diagrams.</li> <li>2. Replace fan switch.</li> <li>3. Check motor amps against motor name plate rating, check voltage, replace fan motor if defective.</li> <li>4. Refer to label on motor.</li> </ol>
Q. Fan motor will not stop.	<ol style="list-style-type: none"> <li>1. Improperly wired fan control.</li> <li>2. Main burners not lighting while thermostat calls for heat.</li> <li>3. Defective fan switch.</li> </ol>	<ol style="list-style-type: none"> <li>1. Check all wiring.</li> <li>2. Refer to H or N symptoms.</li> <li>3. Replace fan switch.</li> </ol>
R. Not enough heat.	<ol style="list-style-type: none"> <li>1. Incorrect gas input.</li> <li>2. Heater undersized.</li> <li>3. Thermostat malfunction.</li> <li>4. Heater cycling on high limit .</li> </ol>	<ol style="list-style-type: none"> <li>1. Refer to "Operation".</li> <li>2. This is especially true when the heated space is enlarged. Have the heat loss calculated and compare to heater output (80% of input). Your gas supplier or installer can furnish this information. If heater is undersized, add additional heaters.</li> <li>3. Replace thermostat.</li> <li>4. There should be NO ducts attached to the front of this heater. Check air movement through heat exchanger. Check voltage to fan motor. Clean fan blade and heat exchanger and oil fan motor.</li> </ol>
S. Too much heat.	<ol style="list-style-type: none"> <li>1. Thermostat malfunction.</li> <li>2. Heater runs continuously.</li> </ol>	<ol style="list-style-type: none"> <li>1. Replace thermostat.</li> <li>2. Check wiring per diagrams; Check operation at valve. Look for short (such as staples piercing thermostat wiring) and correct: Replace gas valve, Refer to "Operation".</li> </ol>

**Table 6 - Tubular Propeller Troubleshooting Guide**

<b>SYMPTOMS</b>	<b>POSSIBLE CAUSE(S)</b>	<b>CORRECTIVE ACTION</b>
T. Cold air is delivered on start up.	1. Fan relay heater element improperly wired.	1. Be sure fan relay heater terminals are connected per diagrams.
U. Cold air is delivered during heater operation.	1. Incorrect manifold pressure or input. 2. Voltage to unit too high. 3. Air throughput too high.	1. Refer to "Operation". 2. Check motor voltage with fan running. Should be 115 volts AC. 3. Refer to "Operation".
V. Hot surface element not glowing or NO spark (some models).	1. Thermostat not calling for heat. 2. No low voltage. 3. Spark gap closed or too wide. 4. Broken or cracked ceramic on spark electrode. 5. Broken hot surface element.	1. Close thermostat contacts. 2. Check for 24V across 24V terminals of ignitor. 3. Set gap to 0.1". 4. Replace pilot assembly. 5. Replace hot surface element.
W. Ignition source present, but pilot does not light.	1. Loose ignitor connections. 2. Improper gas pressure. 3. Is ignition source in pilot gas stream? 4. No pilot gas — do not use match to test - presence of gas is easily detected by the odor.	1. Check all connections - terminal PV feeds 24V to the pilot valve. 2. Check pressure — pressure too high or too low may cause a problem. 3. Spark should arc from electrode. 4. Check pilot line for kinks. Ensure there are no drafts.
X. Pilot lights — Main valve does not energize.	1. Loose ignitor connections. 2. Cracked or broken sensor ceramic. 3. Check sensor/spark lead for continuity. 4. Measure 24 volts from terminals MV to terminals MV/PV.	1. Check connections- terminal MV feeds main valve. 2. Replace pilot assembly. 3. Replace if needed. 4. If present, replace main valve; if not, replace igniter.
Y. Hi-Limit switch tripping.	1. Unit is overfiring. 2. Air flow too low 3. Defective switch.	1. Burner orifice may be too large: verify/replace if required. 2. Increase air flow; check fan size. Check for proper voltage. 3. Replace.
Z. Noisy power ventor.	1. Power ventor wheel loose. 2. Power ventor wheel dirty. 3. Power ventor wheel rubbing housing. 4. Bearings are dry.	1. Replace or tighten. 2. Clean power ventor wheel. 3. Realign power ventor wheel. 4. Oil bearings on power ventor motor. (Refer to label on motor).
AA. Power ventor will not run.	1. Loose wiring. 2. Defective motor overload protector or defective motor. 3. Defective power ventor relay.	1. Check and tighten all wiring connections per diagrams. See "Electrical Connections". 2. Replace motor. 3. Check for 24V across 1 and 3 terminals on fan relay. If 24V is present, jumper terminals numbered 2 and 4. If motor runs, the relay is defective and must be replaced. If 24V is not present, check wiring per diagrams.
BB. Power ventor turns on and off while burners are operating.	1. Power ventor relay improperly wired. 2. Defective ventor relay switch. 3. Motor overload protector cycling on and off. 4. Motor not properly oiled.	1. Be sure ventor relay terminals are connected per diagrams. 2. Replace ventor relay. 3. Check motor amps against motor name plate rating, check voltage, replace power ventor motor if defective. 4. Refer to label on motor.

**Table 6 - Tubular Propeller Trouble Shooting with LED Indicator Assistance**

No Cycling or appliance power or thermostat call for heat since appliance failure has occurred.

**▲ WARNING**

**Line voltage power can cause product damage, severe injury or death. Only a trained experienced service technician should perform this trouble-shooting.**

1. Check the system thermostat to make sure it is calling for heat. (Do not cycle the thermostat on and off at this time.)
2. Remove the appliance burner compartment door. Do not interrupt power to the SV9540; SV9640 by opening any electrically interlocked panels.
3. Observe the LED indicator on the SV9540; SV9640; check and repair system as noted in the chart to the right.

**\*NOTICE: Air flow proving switch and power ventor hose barbs must be free of any dust or debris at all times. Periodically check these openings and/or if any problems occur.**

LED STATUS	INDICATES	CHECK/REPAIR
Off	No power to system control	<ol style="list-style-type: none"> <li>1. Line voltage input power at L1 and L2 connector.</li> <li>2. Low voltage (24V) power at 24 VAC and COM.</li> <li>3. System wiring harness is in good condition and securely connected at both ends.</li> </ol>
Bright – Dim	Normal operation This indication shows whenever the system is powered, unless some abnormal event has occurred.	Not Applicable
2 Flashes	<p>Airflow proving switch remains closed longer than 30 seconds after a call for heat begins.</p> <p>Combustion air blower is not energized until airflow proving switch opens.</p>	<ol style="list-style-type: none"> <li>1. Airflow proving switch stuck closed.</li> <li>2. Airflow proving switch miswired or jumpered.</li> </ol>
3 Flashes*	<p>Airflow proving switch remains open longer than 30 seconds after combustion air blower energized</p> <p>System goes into 5-minute delay period, with combustion air blower off. At the end of the 5-minute delay, another ignition cycle will begin.</p>	<ol style="list-style-type: none"> <li>1. Ignition system control switch must be in the ON position.</li> <li>2. Airflow proving switch operation, tubing and wiring.</li> <li>3. Obstructions or restrictions in appliance air intake or exhaust flue system that prevent proper combustion airflow.</li> </ol>
4 Flashes	Limit string is open.	<ol style="list-style-type: none"> <li>1. Open manual reset or auto reset burner rollout switch.</li> <li>2. Open high temperature or auxiliary limit switch.</li> <li>3. Limit and rollout switch wiring is in good condition and securely connected.</li> </ol>
5 Flashes	Flame signal sensed out of sequence.	<ol style="list-style-type: none"> <li>1. Flame at pilot burner.</li> </ol>
6 Flashes	System Lockout After 5-minute delay time, control system will reset and initiate a new ignition sequence, if the call for heat is present.	<ol style="list-style-type: none"> <li>1. Gas supply off or at too low pressure to operate appliance.</li> <li>2. Damaged or broken HSI element.</li> <li>3. Line voltage HOT lead wire not connected to L1 terminal (check polarity)</li> <li>4. Appliance not properly earth grounded.</li> <li>5. Flame sense rod contaminated or in incorrect location.</li> <li>6. Be sure pilot burner lead wires are in good condition and properly connected.</li> </ol>



# MAINTENANCE

## PERIODIC SERVICE

**NOTICE: The heater and vent system should be checked once a year by a qualified technician.**

All Maintenance/Service information should be recorded accordingly on the Inspection Sheet provided in this manual.

**▲ WARNING** Open all disconnect switches and disconnect all electrical and gas supplies and secure in that position before servicing unit. Failure to do so may result in personal injury or death from electrical shock.

Should maintenance be required, perform the following inspection and service routine:

1. Inspect the area near the unit to be sure that there is no combustible material located within the minimum clearance requirements listed in this manual.

**▲ WARNING** Under no circumstances should combustible material be located within the clearances specified in this manual. Failure to provide proper clearance could result in personal injury or equipment damage from fire.

2. Turn off the manual gas valve and electrical power to the unit heater.
3. To clean or replace the main burners, remove burner cover. Remove top strip from above main burners. Lift burners up and pull away from manifold to remove.
4. With the burners removed, wire brush the inside surfaces of the heat exchanger.

5. Remove any dirt, dust, or other foreign matter from the burners using a wire brush and/or compressed air. Ensure that all parts are unobstructed. Inspect and clean the pilot burner if necessary.
6. Reassemble the unit heater by replacing all parts in reverse order.
7. Relight the pilot (see lighting instruction on the unit nameplate). Complete the appropriate unit startup procedure as given in the "Operation" section of this manual.
8. Check the burner adjustment.
9. Check all gas control valves and pipe connections for leaks.
10. Check the operation of the automatic gas valve by lowering the setting of the thermostat, stopping the operation of the gas duct furnace. The gas valve should close tightly, completely extinguishing the flame on the main burners.
11. Inspect and service motor/fan assembly. To maintain efficient air flow, inspect and clean the fan blades and guard to prevent buildup of foreign matter.
12. Check lubrication instructions on motor. If oiling is required, add 3 or 4 drops of electric motor oil as follows:
  - a. Light Duty - After 3 years or 25,000 hours of operation.
  - b. Average Duty - Annually after 3 years or 8,000 hours of operation.
  - c. Heavy Duty - Annually after 1 year or at least 1500 hours of operation.

**▲ CAUTION** Never over oil the motor or premature failure may occur!

14. Check and test the operational functions of all safety devices supplied with your unit.

## LIMITED WARRANTY

### Power Vented Tubular Propeller Unit Heaters

1. The "Manufacturer" warrants to the original owner at original installation site that the above model Gas-Fired Heater ("the Product") will be free from defects in material or workmanship for (1) year from the date of shipment from the factory, or one and one-half (1-1/2) years from the date of manufacture, whichever occurs first. The Manufacturer further warrants that the complete heat exchanger, and burners be free from defects in material or workmanship for a period of ten (10) years from the date of manufacture. If upon examination by the Manufacturer the Product is shown to have a defect in material or workmanship during the warranty period, the manufacturer will repair or replace, at its option, that part of the Product which is shown to be defective.
2. This limited warranty does not apply:
  - a. if the product has been subjected to misuse or neglect, has been accidentally or intentionally damaged, has not been installed, maintained, or operated in accordance with furnished written instructions, or has been altered or modified in any way by any unauthorized person.
  - b. to any expenses, including labor or material, incurred during removal or reinstallation of the Product
  - c. to any damage due to corrosion by chemicals, including halogenated hydrocarbons, precipitated in the air
  - d. to any workmanship of the installer of the Product
3. This limited warranty is conditional upon:
  - a. advising the installing contractor, who in turn notify the distributor or manufacturer
  - b. shipment to the Manufacturer of that part of the Product thought to be defective. Goods can only be returned with prior written approval of the Manufacturer. All returns must be freight prepaid.
  - c. determination in the reasonable opinion of the Manufacturer that there exists a defect in material or workmanship
4. Repair or replacement of any part under this Limited Warranty shall not extend the duration of the warranty with respect to such repaired or replaced part beyond the stated warranty period.
5. **THIS LIMITED WARRANTY IS IN LIEU OF ALL WARRANTIES, EITHER EXPRESS OR IMPLIED, AND ALL SUCH OTHER WARRANTIES, INCLUDING WITHOUT LIMITATION IMPLIED WARRANTIES OF MERCHANTABILITY OR FITNESS FOR A PARTICULAR PURPOSE, ARE HEREBY DISCLAIMED AND EXCLUDED FROM THIS LIMITED WARRANTY. IN NO EVENT SHALL THE MANUFACTURER BE LIABLE IN ANY WAY FOR ANY CONSEQUENTIAL, SPECIAL, OR INCIDENTAL DAMAGES OF ANY NATURE WHATSOEVER, OR FOR ANY AMOUNTS IN EXCESS OF THE SELLING PRICE OF THE PRODUCT OR ANY PARTS THEREOF FOUND TO BE DEFECTIVE. THIS LIMITED WARRANTY GIVES THE ORIGINAL OWNER OF THE PRODUCT SPECIFIC LEGAL RIGHTS. YOU MAY ALSO HAVE OTHER RIGHTS WHICH MAY VARY BY JURISDICTION.**

*In the interest of product improvement, we reserve the right to make changes without notice.*

# IDENTIFICATION OF PARTS PROPELLER UNIT HEATERS

Figure 11 - Propeller Parts

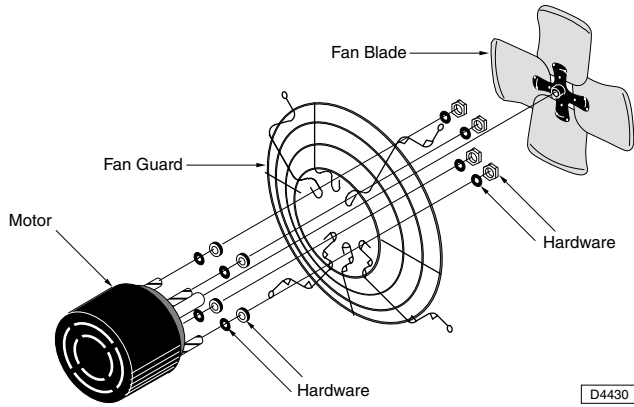

Figure 12 - Component Parts

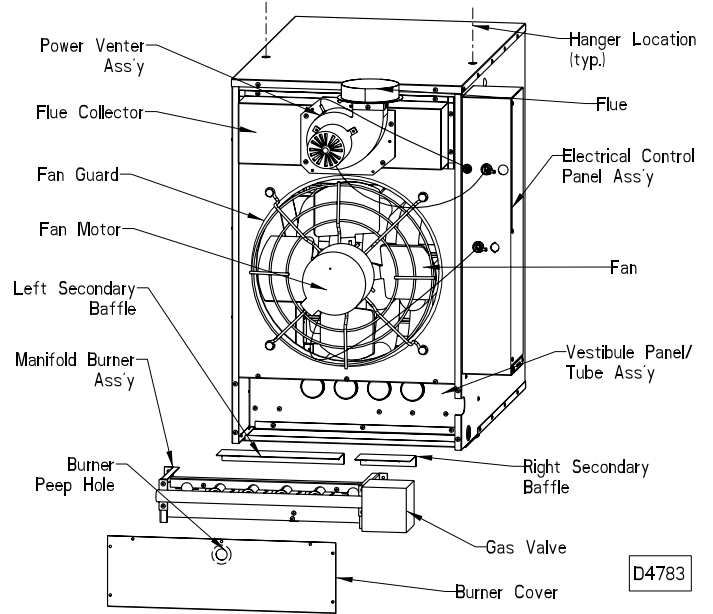

Figure 13 - Heat Exchanger Assembly

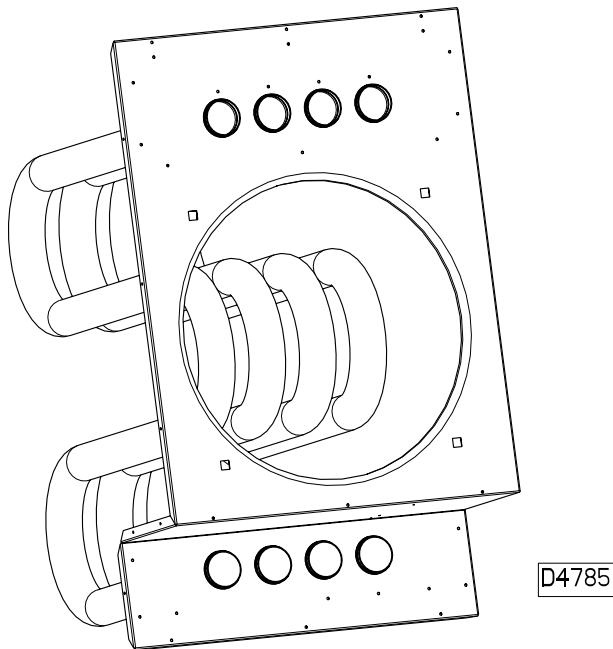
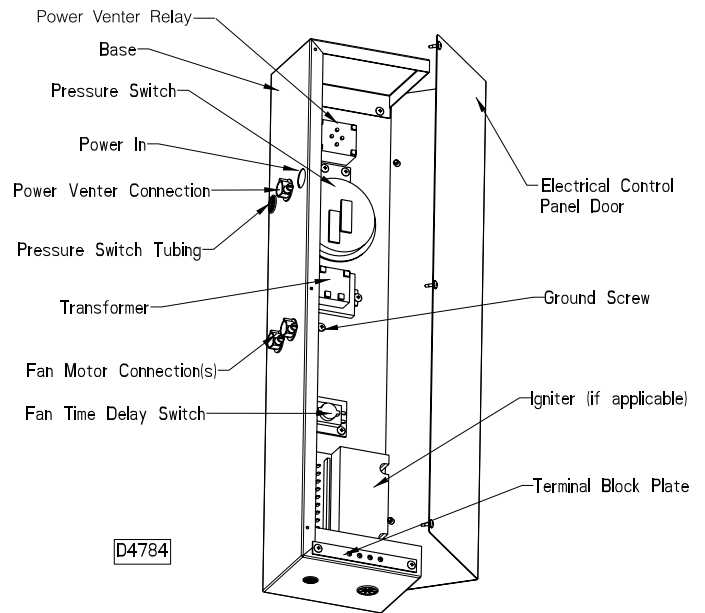
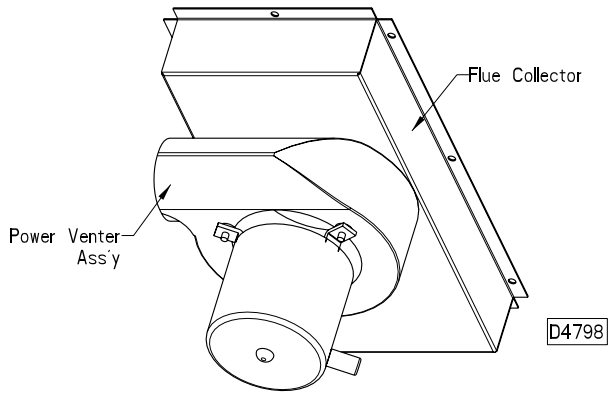

Figure 14 - Electrical Control Panel



**Figure 15 - Power Venter Assembly  
(100/250 Unit Sizes Shown)**



**Figure 16 - Power Venter Assembly  
(300/400 Unit Sizes Shown)**

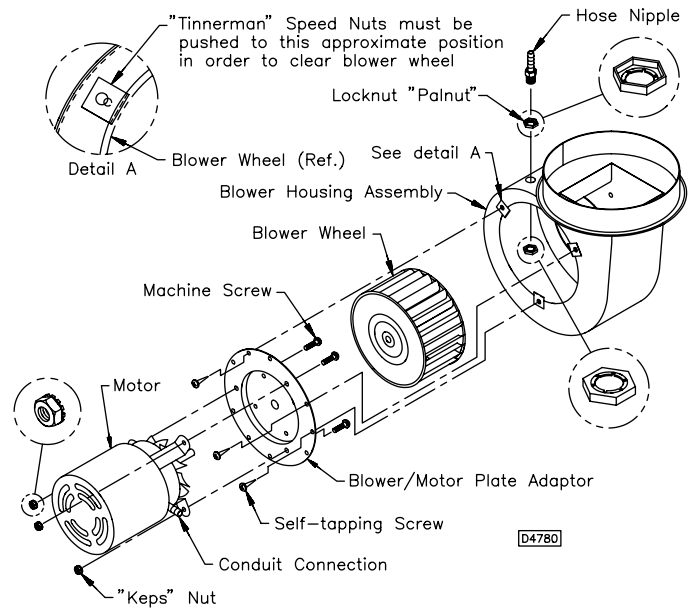

**Figure 17 - Turbulator/High Limit Location**

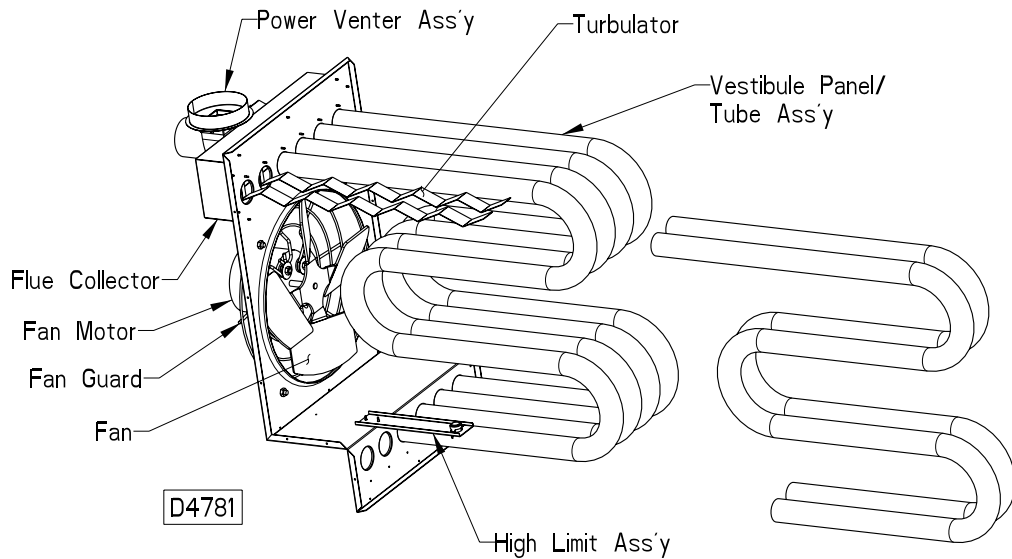

## HOW TO ORDER REPLACEMENT PARTS

Please send the following information to your local representative: if further assistance is needed, contact the manufacturer's customer service department.

- Model Number
- Serial Number (if any)
- Part Description and Number as shown in Replacement parts Catalog

# GAS EQUIPMENT START-UP

Customer \_\_\_\_\_ Job Name & Number \_\_\_\_\_

## PRE-INSPECTION INFORMATION With power and gas off.

Type of Equip: Unit Heater

Serial Number \_\_\_\_\_ Model Number \_\_\_\_\_

Name Plate Voltage: \_\_\_\_\_ Name Plate Amperage: \_\_\_\_\_

Type of Gas: Natural LP Tank Capacity \_\_\_\_\_ lbs. Rating: \_\_\_\_\_ BTU @ \_\_\_\_\_ °F  
\_\_\_\_\_ kg \_\_\_\_\_ kw @ \_\_\_\_\_ °C

- Are all panels, doors, vent caps in place?
- Has the unit suffered any external damage? Damage \_\_\_\_\_
- Does the gas piping and electric wiring appear to be installed in a professional manner?
- Has the gas and electric been inspected by the local authority having jurisdiction?
- Is the gas supply properly sized for the equipment?
- Were the installation instructions followed when the equipment was installed?
- Have all field installed controls been installed?
- Do you understand all the controls on this equipment? ***If not, contact your wholesaler or rep.***  
***(DO NOT START this equipment unless you fully understand the controls.)***

### GENERAL

#### With power and gas off.

- Make certain all packing has been removed.
- Tighten all electrical terminals and connections.
- Check damper linkages for tightness.
- Check all fans & blowers for free movement.
- Check all controls for proper settings.

### GAS HEATING

#### With power and gas on.

- Inlet gas pressure. \_\_\_\_\_ in. W.C. or \_\_\_\_\_ kPa
- Pilot & main burner ignition.
- Manifold gas pressure. \_\_\_\_\_ in. W.C. or \_\_\_\_\_ kPa
- Cycle on HIGH LIMIT.
- Cycle firestat and/or freezestat.
- Check electronic modulation. Set at: \_\_\_\_\_
- Check mechanical modulation. Set at: \_\_\_\_\_
- Cycle and check all other controls not listed.
- Check operation of remote panel.
- Entering air temp. \_\_\_\_\_ °F or \_\_\_\_\_ °C
- Discharge air temp. (high fire) \_\_\_\_\_ °F. or \_\_\_\_\_ °C
- External static pressure \_\_\_\_\_ in. W.C.
- Cycle by thermostat or operating control.

Remarks: \_\_\_\_\_

\_\_\_\_\_

\_\_\_\_\_