

COMBUSTION RESEARCH CORPORATION

FOR YOUR SAFETY

If you smell gas:

1. Open windows
2. **DO NOT** try to light any appliance
3. **DO NOT** use electrical switches
4. **DO NOT** use any telephone in your building
5. Leave the Building
6. Immediately call your local gas supplier after leaving the building. Follow gas supplier's instructions.
7. If you cannot reach your gas supplier, call the fire department.

WARNING



Fire Hazard

Do not store or use gasoline or other flammable vapors and liquids in the vicinity of this or any other appliance.

Some objects will catch fire or explode when placed near this heater.

Failure to follow these instructions can result in death, injury or property damage.

Omega II®

Pre Engineered Packages

Gas fired, Low Intensity Infrared Unitary Infrared Heating Systems Installation, Operating, Maintenance and Parts Manual

WARNING



Read and understand these installation, operating and maintenance instructions thoroughly before installing or servicing this equipment. Only trained, qualified gas installation and service personnel may install or service this equipment.



A gas-fired appliance could expose you to substances in fuel or fuel combustion, which has been determined by the State of California to cause cancer, birth defects, or other reproductive harm. Contact factory for further information.

Installer

Please take time to read and understand these instructions prior to any installation. Installer must give a copy of this manual to the owner

Owner

Keep this manual in a safe place in order to provide your serviceman with the necessary information.

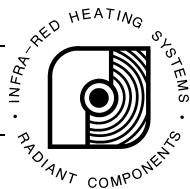

Combustion Research Corp.
2516 Leach Rd.
Rochester Hills, MI 48309-3555
Telephone: 248.852.3611
Fax: 248.852.9165

www.combustionresearch.com



! WARNING



FIRE OR EXPLOSION HAZARD

Can cause death, severe injury and/or property damage.

1. Read this manual carefully before installing or servicing this equipment. Improper installation, service or maintenance can cause death, injury and/or property damage.
2. Check clearances given on the outside of each burner to make sure the product is suitable for your application.
3. Installer must be a trained, experienced service technician.
4. All service must be performed only by a trained service technician or representative
5. After installation is complete, check system operation as provided in these instructions.

Combustibles: Failure to maintain the specified minimum clearances to combustibles could result in a serious fire hazard. Do not locate flammable or combustible materials within this distance. Signs must be posted near thermostat and in storage areas to specify maximum stacking height to maintain required clearances to combustibles. Do not locate in hazardous atmospheres containing flammable vapors or combustible dust.

United States: Installations in public garages or airplane hangars are permitted when in accordance with NFPA-88 (latest edition) and NFPA-409 (latest edition) Codes.

Canada: Installation in public garages and airplane hangars is permitted when in accordance with CAN/CGA B.149.1 & CAN/CGA B149.2.

Vehicles: Minimum clearances must be maintained from vehicles parked, below the heater. Ensure that adequate clearance is maintained where vehicles are in operation or being serviced.

Gas Connection: There is an expansion of the radiant pipe With each firing cycle, and this will cause the burner to move with respect to the gas line. This can cause a gas leak resulting in an unsafe condition if the gas connection in not made strictly in accordance with page 13 of these instructions.

Ignition: This appliance does not have a pilot. It is equipped with an ignition device, which automatically lights the burner. Do not try to light the burner by hand.

Mechanical Hazard - Vacuum Exhauster: High speed rotating vacuum exhauster impeller/wheel can cause severe injury. Do not operate the vacuum exhauster without impeller. Loose clothing can be drawn into unguarded inlet and entangle with impeller wheel. Keep hands and fingers away from inlet and outlet. Install exhaust duct with "bird screen" or approved vent cap on vacuum exhauster outlet.

Mechanical Hazard - Suspension: Use appropriate suspension hardware, beam clamps (rod or perforated strap) and turnbuckles at predetermined locations. The weight and normal movement of the heating system may cause support failure if the following minimum suspension requirements are not met: Distance between combination hangers must be 10-ft. (3 M) or less; chain size must be 3/0 minimum or equivalent.

NOTICE

Failure to follow these instructions can cause personal injury or property damage:

Caution must be used when running the system near combustible materials such as wood, paper, rubber, etc. Consideration should be given to partitions, storage racks, hoists, building construction, etc. Page 16 & 17 outlines minimum acceptable clearances to combustibles.

If the building has a slight negative pressure or contaminants are present in the air, an outside combustion air supply to the heaters is strongly recommended.

Do not use in an atmosphere containing halogenated hydrocarbons or other corrosive chemicals. Some compounds in the air can be drawn into the equipment and can cause an accelerated rate of corrosion of some parts of the radiant heat exchanger. The use of such chemical compounds in or near the enclosure should be avoided where a longer life of the burner, tubing and other parts is desirable.



CAUTION

Failure to follow these instructions can cause damage to the system components:

DO NOT high-pressure test the gas piping with the burners connected. Failure to follow this procedure will exceed the pressure rating of burner gas controls and this will **require complete replacement of these parts.**

DO NOT operate a blower with an unrestricted inlet. An unrestricted airflow will overload the motor, which can cause burnout or failure.

This heater is designed for heating nonresidential indoor spaces. These instructions, the layout drawing, local codes and ordinances, and applicable standards that apply to gas piping, electrical wiring, venting, etc. must be thoroughly understood before proceeding with the installation.

INSTALLER

PLEASE TAKE TIME TO READ AND UNDERSTAND THESE INSTRUCTIONS PRIOR TO ANY INSTALLATION. Contact your representative or the factory if you have any questions

OWNER

Retain this manual in a safe place to provide your serviceman with information if the situation arises.

TABLE OF CONTENTS

	PAGE(S)
Heater Safety & Burner Label Placement	1 & 2
Warning Symbols	3
Standards, Certifications and Codes	3 & 4
Installer Qualifications & Responsibility	4
Assembly – Tube and Reflectors	5 - 7
Suspension Methods	8
Combustion Tube Installation	9
Reflector Mounting	9
Customizing System	9
Seismic Restraint Suspension	10
Burner Connection & Installation	11
Gas Supply	12
Flexible gas Connector Installation	13
Technical Data	14
System Dimensions	15
Clearance To Combustibles	16 & 17
Side Shield Installation	18
Combustion Air	19 & 20
Venting	22 – 24
Electrical Information	25
Thermostat Wiring	27
System Start-Up	28 & 29
Sequence Of Operation	29
Service & Maintenance	29 – 33
Trouble Shooting Flow Chart	34 & 35
Burner Parts List	36 & 37
Accessories & Optional Equipment	38 – 40
Warranty Statement and Terms and Conditions	41 & 42
Sample Clearance To Combustible Warning Sign	43

Omega II® heating systems DO NOT qualify for use in explosion proof installations. Heaters SHALL NOT be used in living/sleeping areas.

2016 COMBUSTION RESEARCH CORPORATION, INC.

All rights reserved. No part of this work covered by the copyrights hereon in may be reproduced or copied in any form or by any means - graphic, electronic, or mechanical, including photocopying, recording, taping, or information storage and retrieval systems - without written permission of COMBUSTION RESEARCH CORPORATION, Inc.

This Page Intentionally Left Blank

HEATER SAFETY



Please take time to familiarize yourself this manual as your safety is important is important to us. This symbol is used throughout this manual to notify you of possible fire, electrical, burn hazards or other safety issues. Pay special attention when reading this manual and

follow the warnings.

Read this manual carefully before installation, operation or service of this equipment.

Protective gear (including safety glasses) is to be worn during installation, set up and service. Sheet metal components, including the aluminum reflectors and field cut radiant tubes used on this system as well as various venting components have sharp edges. The use of gloves

will also help in reducing the transfer of dirt and oils to the surface of the reflectors.

If additional Installation, Operation and Service Manuals are needed, contact your Combustion Research Corporation independent representative or Combustion Research Corporation. The IOM's can also be found at www.combustionresearch.com.

In order to help prevent personal injury and damage to the heater components, at least two persons will be required for installation.

SAFETY LABELS AND THEIR LOCATION

Product safety signs or labels should be replaced by the end user or servicing contractor when they are no longer legible or have been damaged. Please contact Combustion Research Corp. or your Combustion Research Corp. independent representative to obtain signs or labels.



Bottom Panel



Logo Label
P/N 900.2708

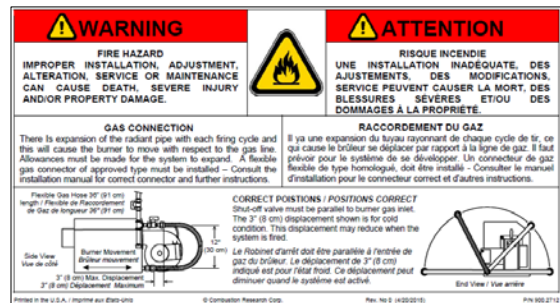

Gas Connector Label
P/N 900.2712

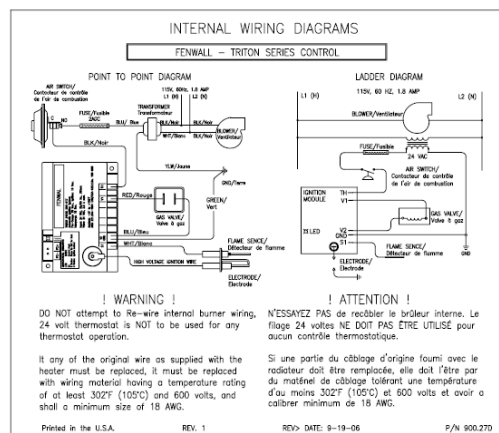

Wiring Schematic located inside Bottom Panel
P/N 900.27D

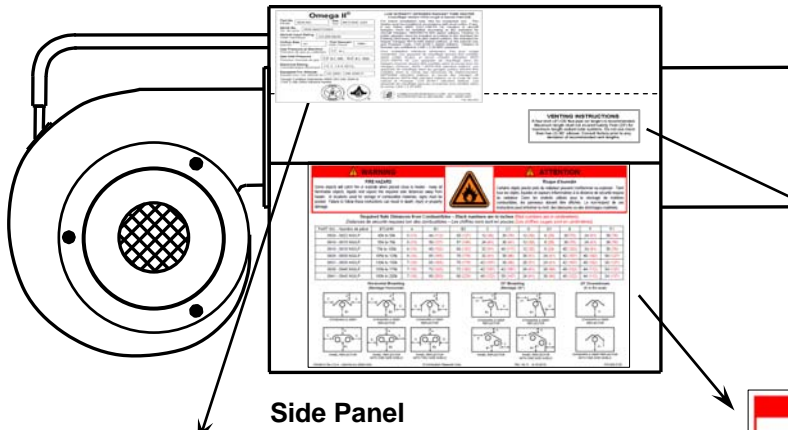

Side Panel

VENTING INSTRUCTIONS
A four-inch (4") OD fue pipe (or larger) is recommended. Maximum length shall not exceed twenty feet (20') for maximum length radiant tube systems. Do not use more than two (2) 90° elbows. Consult factory prior to any deviation of recommended vent lengths.

Venting Instructions Label

Omega II®
LOW INTENSITY INFRARED RADIANT TUBE HEATER
Chauffage radiant infra-rouge à basse-intensité

Part No. 0900 NG Gas NATURAL GAS
Model No. 0900 NA0730001
Normal Input Rating 125,000 Btu/hr
Orifice Size .81 "Hot Vacuum" .036 "Cold"
Gas Pressure at Manifold 5.0" w.c. max. 14.0" w.c. max.
Electrical Rating 115 V, 1.8 A, 60 Hz
Equipped For Altitude 10,000' / CAN 2100' FT
Design Certified Standards ANSI Z39.2-2004 & CSA 2.34-2004 Infrared Heater

For indoor installation only. Not for residential use. This heater must be installed in accordance with local codes, if any, if not, follow ANSI Z223.1 NFPA 54 Heaters in Aircraft Hangars, ANSI NFPA 409 (latest edition). Heaters in public garages must be installed according to the standard for Parking Structures, NFPA 88A (latest edition), the standard for Repair Garages NFPA 489 (latest edition), or the national Gas and Piping Code, CSA B149.1 (latest edition). Heaters in Brooder are certified to CAN 12.20 MRS standard.

Placard information (read before use) must be installed on the heater. The heater must be installed in accordance with local codes, if any, if not, follow ANSI Z223.1 NFPA 54 Heaters in Aircraft Hangars, ANSI NFPA 409 (latest edition), the standard for Parking Structures, NFPA 88A (latest edition), the standard for Repair Garages NFPA 489 (latest edition), or the national Gas and Piping Code, CSA B149.1 (latest edition). Heaters in Brooder are certified to CAN 12.20 MRS standard.

COMBUSTION RESEARCH CORP. 2518 LEACH RD. ROCHESTER HILLS, MICHIGAN, USA 48063-2000 P/N 900.2601

Rating Plate Label
P/N 900.2601

WARNING FIRE HAZARD
Some objects will catch fire or explode when placed close to heater. Keep all flammable objects, liquids and vapors the required safe distance away from heater. In locations used for storage of combustible materials, signs must be posted. Failure to follow these instructions can result in injury, death or property damage.

ATTENTION Risque d'incendie
Certains objets placés près du radiateur peuvent s'enflammer ou exploser. Tenez les objets, liquides et vapeurs inflammables à la distance de sécurité requise du radiateur. Dans les endroits utilisés pour le stockage de matériaux combustibles, les panneaux doivent être affichés. Le non-respect de ces instructions peut entraîner un mort, des blessures ou des dommages matériels.

Required Safe Distances from Combustibles - Black numbers are in inches (Red numbers are in centimeters)
Distances de sécurité requises loin des combustibles - Les chiffres noirs sont en pouces (Les chiffres rouges sont en centimètres)

PART NO. - Numéro de pièce	BTU/HOUR	A	B1	B2	C	C1	D	E	F	F1
0900-0900 NGSLP	400 to 700	5 (13)	50 (127)	50 (127)	12 (30)	6 (20)	30 (76)	24 (61)	30 (76)	
0910-0910 NGSLP	750 to 1000	8 (16)	60 (152)	60 (152)	32 (81)	48 (117)	42 (107)	48 (122)	24 (61)	30 (76)
0920-0920 NGSLP	1050 to 1200	8 (16)	65 (165)	70 (178)	32 (81)	36 (91)	20 (51)	24 (61)	40 (102)	50 (127)
0931-0931 NGSLP	1300 to 1500	7 (18)	65 (165)	70 (178)	42 (107)	36 (91)	20 (51)	24 (61)	42 (107)	50 (127)
0930-0940 NGSLP	1550 to 1750	7 (18)	72 (183)	72 (183)	42 (107)	24 (61)	30 (76)	48 (122)	44 (112)	54 (137)
0941-0945 NGSLP	1800 to 2000	7 (18)	80 (203)	80 (203)	42 (107)	24 (61)	30 (76)	48 (122)	44 (112)	54 (137)

Horizontal Mounting (Montage Horizontal)
3P Mounting (Montage 3P)
2P Downstream (2P en aval)

Panel Reflector, Panel Reflector with 90° Bend, Panel Reflector with 90° Bend

Made in the U.S.A. - Fabriqué aux États-Unis
© Combustion Research Corp.
P/N 900.2730

Clearance to Combustibles Label
P/N 900.2730

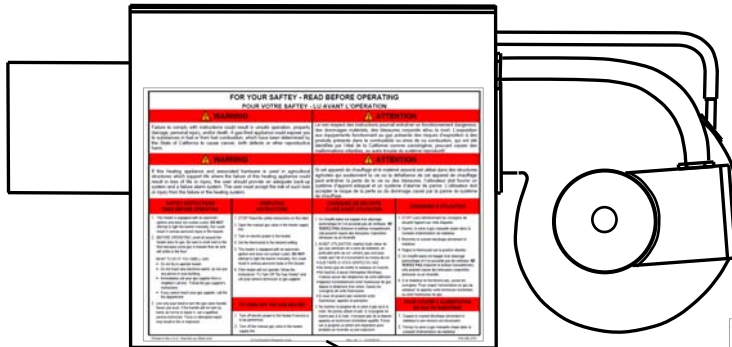

Side Panel

FOR YOUR SAFETY - READ BEFORE OPERATING
POUR VOTRE SÉCURITÉ - LU AVANT L'OPÉRATION

WARNING Failure to comply with instructions could result in unsafe operation, property damage, personal injury, and/or death. A gas-fired appliance could explode due to substances in fuel or from fuel combustion, which have been determined by the State of California to cause cancer, birth defects or other reproductive harm.

ATTENTION Le non-respect des instructions pourrait entraîner un fonctionnement dangereux, des dommages matériels, des blessures corporelles et/ou la mort. L'explosion des équipements fonctionnant au gaz présente des risques d'explosion à des produits présents dans le combustible ou émis de sa combustion, qui ont été identifiés par l'état de la Californie comme cancérigènes, pouvant causer des malformations congénitales, ou des troubles de développement reproductif.

WARNING If this heating appliance and associated hardware is used in agricultural structures which support life where the failure of this heating appliance could result in loss of life or injury, the user should provide an adequate back-up system and a failure alarm system. The user must accept the risk of such loss or injury from the failure of the heating system.

ATTENTION Si cet appareil de chauffage et le matériel associé est utilisé dans des structures agricoles qui soutiennent la vie où la défaillance de cet appareil de chauffage peut entraîner la perte de la vie ou des blessures, l'utilisateur doit fournir un système d'appoint adéquat et un système d'alarme de panne. L'utilisateur doit accepter le risque de la perte ou du dommage causé par la panne du système de chauffage.

WARNING 1. This heater is resistant with an automatic ignition and will continue to fire 600 MEG before it shuts the burner normally. Do not touch any electrical parts of the heater. 2. BEFORE OPERATING, check all around the heater area for gas. Do not be sure to read the label on the front. 3. Do not try to operate heater. 4. Do not try to operate heater. 5. Do not touch any electrical parts, or do not use any phone in your building. 6. Immediately call your gas supplier from a neighbor's phone. Follow the gas supplier's instructions. 7. If you cannot reach your gas supplier call the fire department. 8. Use only your hand to turn the gas valve handle. Do not use tools. Do not touch the handle of the gas valve if it is hot. Do not touch the handle of the gas valve if it is hot. Do not touch the handle of the gas valve if it is hot. Do not touch the handle of the gas valve if it is hot.

ATTENTION 1. Ce chauffe-bain est équipé d'un allumage automatique et continuera de fonctionner pendant 600 mégajoules avant que le brûleur ne s'éteigne normalement. 2. AVANT L'UTILISATION, vérifiez toute zone au gaz dans tout l'espace de la zone de destination. 3. Ne touchez aucune partie électrique de ce chauffe-bain. 4. Avant de fonctionner, vérifiez toute zone au gaz dans tout l'espace de la zone de destination. 5. Ne touchez aucune partie électrique de ce chauffe-bain. 6. Appelez immédiatement votre fournisseur de gaz dès que vous ne pouvez pas contacter votre fournisseur de gaz. 7. Si vous ne pouvez pas contacter votre fournisseur de gaz, appelez le département des pompiers. 8. Utilisez uniquement votre main pour tourner la poignée de la vanne à gaz. Ne touchez pas la poignée de la vanne à gaz si elle est chaude. Ne touchez pas la poignée de la vanne à gaz si elle est chaude. Ne touchez pas la poignée de la vanne à gaz si elle est chaude. Ne touchez pas la poignée de la vanne à gaz si elle est chaude.

WARNING 1. STOP: Read the safety instructions on this label. 2. Open the manual gas valve in the heater safety line. 3. Turn on electric power to the heater. 4. Use the thermostat to the desired setting. 5. The heater is equipped with an automatic ignition and will continue to fire 600 MEG before it shuts the burner normally. Do not touch any electrical parts of the heater. 6. Immediately call your gas supplier from a neighbor's phone. Follow the gas supplier's instructions. 7. If you cannot reach your gas supplier call the fire department. 8. Use only your hand to turn the gas valve handle. Do not use tools. Do not touch the handle of the gas valve if it is hot. Do not touch the handle of the gas valve if it is hot. Do not touch the handle of the gas valve if it is hot. Do not touch the handle of the gas valve if it is hot.

ATTENTION 1. Arrêtez-vous et lisez attentivement les instructions de sécurité sur cette étiquette. 2. Ouvrez la vanne à gaz manuelle située dans la conduite d'alimentation du radiateur. 3. Branchez le courant électrique alimentant le radiateur. 4. Réglez le thermostat sur le position désiré. 5. Ce chauffe-bain est équipé d'un allumage automatique et continuera de fonctionner pendant 600 mégajoules avant que le brûleur ne s'éteigne normalement. 6. Ne touchez aucune partie électrique de ce chauffe-bain. 7. Appelez immédiatement votre fournisseur de gaz dès que vous ne pouvez pas contacter votre fournisseur de gaz. 8. Utilisez uniquement votre main pour tourner la poignée de la vanne à gaz. Ne touchez pas la poignée de la vanne à gaz si elle est chaude. Ne touchez pas la poignée de la vanne à gaz si elle est chaude. Ne touchez pas la poignée de la vanne à gaz si elle est chaude. Ne touchez pas la poignée de la vanne à gaz si elle est chaude.

WARNING 1. Turn off electric power to the heater. 2. Turn off manual gas valve in the heater safety line. 3. Turn off the manual gas valve in the heater safety line. 4. Turn off the manual gas valve in the heater safety line. 5. Turn off the manual gas valve in the heater safety line. 6. Turn off the manual gas valve in the heater safety line. 7. Turn off the manual gas valve in the heater safety line. 8. Turn off the manual gas valve in the heater safety line.

ATTENTION 1. Coupez le courant électrique alimentant le radiateur. 2. Fermez la vanne à gaz manuelle située dans la conduite d'alimentation du radiateur. 3. Fermez la vanne à gaz manuelle située dans la conduite d'alimentation du radiateur. 4. Fermez la vanne à gaz manuelle située dans la conduite d'alimentation du radiateur. 5. Fermez la vanne à gaz manuelle située dans la conduite d'alimentation du radiateur. 6. Fermez la vanne à gaz manuelle située dans la conduite d'alimentation du radiateur. 7. Fermez la vanne à gaz manuelle située dans la conduite d'alimentation du radiateur. 8. Fermez la vanne à gaz manuelle située dans la conduite d'alimentation du radiateur.

Made in the U.S.A. - Fabriqué aux États-Unis
© Combustion Research Corp.
P/N 900.2701

Operating Instructions Label
P/N 900.2701

WARNING SYMBOLS



Warning indicates a potentially hazardous situation which, if not avoided, could result in death or injury.



Caution indicates a potentially hazardous situation which, if not avoided, could result in minor or moderate injury.



Notice indicates a potentially hazardous situation which, if not avoided, could result in property damage.

CHECKING SHIPMENT

Upon receipt of shipment, check shipment against Bill of Lading for shortages. Also check for external damage to cartons or tube bundles. Shortages and/or external damage to cartons or tubes must be noted on the Bill of Lading in the presence of delivery trucker. The delivery trucker should acknowledge any shortages or damage by initialing this "noted" Bill of Lading.

Claims for damaged material, or shortages that were not evident upon receipt of shipment must be reported to carrier and Combustion Research Corporation Sales Representatives within 72 hours.

Before starting to assemble the heater, make sure that all optional and accessory items are accounted for and are available for assembly. It is also important to verify that the correct gas burner is supplied for the gas service, i.e., natural gas burner for natural gas supply.

IMPORTANT



IMPROPER INSTALLATION CAN CAUSE DEATH, SEVERE INJURY AND/OR PROPERTY DAMAGE.

Read and understand these installation, operating and maintenance instructions thoroughly before installing or servicing this equipment. Only trained, qualified gas installation and service personnel may install or service this equipment.

These instructions, the layout drawing, local codes and ordinances, and applicable standards such as apply to gas piping and electrical wiring must be thoroughly understood before proceeding with the installation.

TESTED UNDER STANDARDS

AMERICAN STANDARDS – Z83.20 (current standard)
CANADIAN STANDARDS – CSA 2.34 (current standard)
GAS FIRED BROODERS - CAN 1-2.20-M85

BUILDING CODES

In the absence of local codes, the installation must conform to the latest edition of:

United States: National Fuel Gas Code, ANSI Z223.1 (NFPA 54).

Canada: CAN/CGA B149.1 and .2, Canadian Electrical Code C22.1

AIRCRAFT HANGERS

Heaters for use in aircraft hangers must be installed in accordance with;

United States: Refer to Standard for Aircraft Hangars, ANSI/NFPA 409 (latest edition).

In Canada: Refer to Standard CAN/CGA B149.1 and B149.2 and applicable Standards for Aircraft Hangars.

Basic guidelines are as follows:

1. Suspended heaters in aircraft storage or service areas shall be installed at least ten feet (10') above the upper surface of wings or engine enclosures of the highest aircraft which may be housed in the hanger. This should be measured from the bottom of the heater to the wing or engine enclosure; whichever is highest from the floor.
2. In other sections of aircraft hangers, such as shops or offices communicating with airplane storage or servicing area, heaters shall be installed in accordance with their listings and mounted not less than eight feet (8') above the floor.
3. Heaters installed in aircraft hangers shall be located so as not to be subject to injury by aircraft, cranes, moveable scaffolding or other objects. Provisions shall be made to ensure accessibility to suspended heaters for recurrent maintenance purposes.

PUBLIC GARAGES

Heaters for use in public garages must be installed in accordance with:

United States: Standard for Parking Structures NFPA 88A (latest edition) or the Code for Motor Fuel Dispensing Facilities and Repair Garages NFPA 30A (latest edition).

Canada: Refer to CAN/CGA B149.1 and B149.2: Installation Codes for Gas Burning Appliances and applicable Standards for Public Garages.:

Basic guidelines are as follows:

1. Heaters shall be installed in accordance with their listings and not be mounted less than eight feet (8') above the floor. Minimum clearances to combustibles must be maintained from vehicles parked below the heater.
2. When installed over hoists, clearance to combustible material must be maintained from upper most point of the hoist, or provided as insulating or reflective barrier on the hoist (consult representative or factory for guidance).

ELECTRICAL GROUNDING

The burner and blower unit must be electrically grounded in accordance with the following codes:

United States: Refer to National Electrical Code®, ANSI/NFPA 70 (latest edition). Wiring must conform to the latest edition of National Electrical Code®, local ordinances, and any special diagrams furnished.

Canada: Refer to Canadian Electrical Code CSA C22.1 Part 1 (latest edition).

GAS INPUT LINES

The method of pipe sizing must conform to the U.S. National Standards: ANSI Z223.1 (current standard) National Fuel Gas Code or CAN 1-B149.1 Installation Code, and should be installed in accordance with all National and Local Codes and ordinances.

CLEARANCES AND ACCESSIBILITY

Inlet air assemblies are to be installed with the air opening pointing toward the ground to protect against rain and snow. Inlet is provided with a bird screen. Adequate clearance must be provided around the inlet air assembly opening to provide an unobstructed entry for the combustion air. The air should be taken from outside the building. Clearances must be sufficient to provide accessibility for servicing. The air inlets must be a minimum of six feet (6') from the exhaust port.

AGRICULTURAL INSTALLATIONS

In agricultural installations *Omega II*® heating systems must be installed as vented systems only.

HAZARDOUS LOCATIONS

Where there is the possibility of exposure to combustible airborne materials or vapor, consult the local Fire Marshal, the fire insurance carrier, or other authorities for approval of the proposed installation. ***Omega II*® heating systems DO NOT qualify for use in explosion proof installations.**

INSTALLER QUALIFICATIONS

Only firms or individuals qualified to perform work in accordance with the applicable specifications should be engaged to install a *Omega II*® system. Consult local Building Inspectors, Fire Marshals, or the local applicable Combustion Research Corporation representative for guidance.

INSTALLER RESPONSIBILITY

Omega II® systems are installed on the basis of information given in a layout drawing. Together with these instructions and the cited codes and regulations comprise the information needed to complete the installation. The installer must furnish all needed material that is not furnished as standard *Omega II*® equipment, and it is his responsibility to see that such materials, as well as the installation methods he uses result in a job that is workman like and in keeping with all applicable codes.

In storage areas where stacking of materials may occur, the installer must provide signs that specify the maximum stacking height so as to maintain the

required clearance to combustibles. A temporary sample sign can be found at the end of the manual.

GENERAL CONSIDERATIONS

Combustion Research Corporation Factory Representatives are experienced in the application of this equipment and can be called on for suggestions about installation which can give the owner of the building a more satisfactory and economical installation.

When installing the *Omega II*® system, take maximum advantage of the building upper structure, beams, Joists, purlins etc. from which to suspend the system. Mount units at minimum height for ease of installation and maintenance but of specified height to fully utilize the building.

The general lay out of the *Omega II*® heating system has been established by the engineering drawing. The *Omega II*® heaters are used to heat building structures as well as localized areas that would include doors, loading docks and isolated workstations throughout the building. The location of the *Omega II*® heaters should be such that the area is covered uniformly, in that the heat is positioned on the perimeter or to each side of the area to be heated, rather than directly overhead. This will give a better comfort condition for workers who would be in these areas. Consult with your representative or the factory for additional guidance in designing the optimum layout for your project.

Omega II® is a suspended system, which requires that consideration be given to the factors that determine its stability, flexibility, safety, and satisfactory operation. Before installation, the contractor should inspect the building along with the owner (or engineer) responsible for the building to check on the use of the building. Inspection of the building including the use of floor space for storage and height of materials stored in the building must be noted so that there are no problems with clearances to combustibles. Particular care should be taken over doors and high objects such as busses, trucks, cranes, car lifts, etc. Whenever possible use side wall penetrations for combustion air inlets to burners and exhaust venting.

DO -

- **Maintain specified clearances to combustibles, and to heat sensitive material, equipment, and workstations.**
 - **Provide approved heat radiation shielding or barriers if needed. Refer to the National Fuel Gas Code for guidance.**
 - **Provide access for general servicing; provide easy access for complete removal of burner and blower.**
 - **Familiarize yourself with local and national codes. Develop a planned installation procedure, which will conserve material and labor on the job. Check to see that all material and equipment is on the job before starting installation. Be sure to accommodate thermal expansion of the hot tube.**
 - **Use the gas connector ONLY as shown in the instructions.**
- Provide end clearance so tubing won't expand and touch a wall or a structural member.**

STRAIGHT & "U" TUBE ASSEMBLY

⚠ CAUTION

CUT HAZARD - SHARP EDGES.

Wear protective gloves when installing and handling and cutting radiant tubes. Failure to follow these instructions will result in personal injury.

1. Remove the Reflector(s), tubes and hanger from the shipping carton. Inspect for shortages and damages as well as correct gas service for burners.
2. Assemble the tubes as illustrated making sure to apply one to two tablespoons (15 – 30 ml) of sealer to the inside edge of the spiral radiant tube. Use a 1" (25.4 mm) dowel or plastic tube to evenly spread the sealer around the inside edge of the spiral radiant tube before sliding the coupler/tube together. **INSTALL COMBUSTION TUBE WITH WELD SEAM ON BOTTOM AND MAKE SURE THAT THE TUBE WITH THE INTERNAL TURBULATOR IS ASSEMBLED IN TUBES AS ILLUSTRATED ON THE FOLLOWING PAGES.**

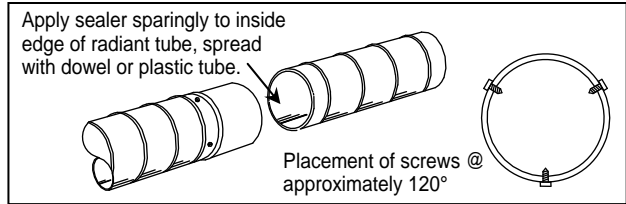
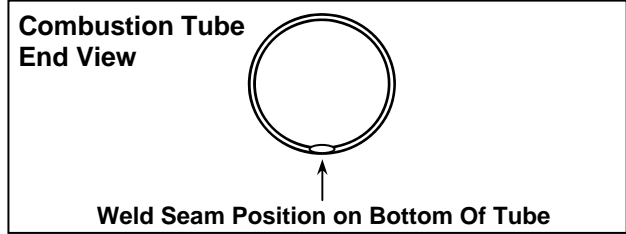

3. Next secure joints with the self drilling and taping screws provided (use three per joint). Clean off excess sealer with a damp cloth.
4. Next install hangers supports by sliding them into place and position them as illustrated. **REFER TO PAGES 6 & 7 FOR PROPER LOCATION. NOTE:** Do not vary the location of the hangers anymore than +/- 4" from the recommendations.

IMPORTANT: Slide the reflectors into place (inside hangers) and overlap them approximately 1" to 2" and secure no more than two together with sheet metal screws. A reflector expansion joint (unsecured reflectors) at every other overlap is required for expansion and contraction of the system.

STRAIGHT TUBE SYSTEMS

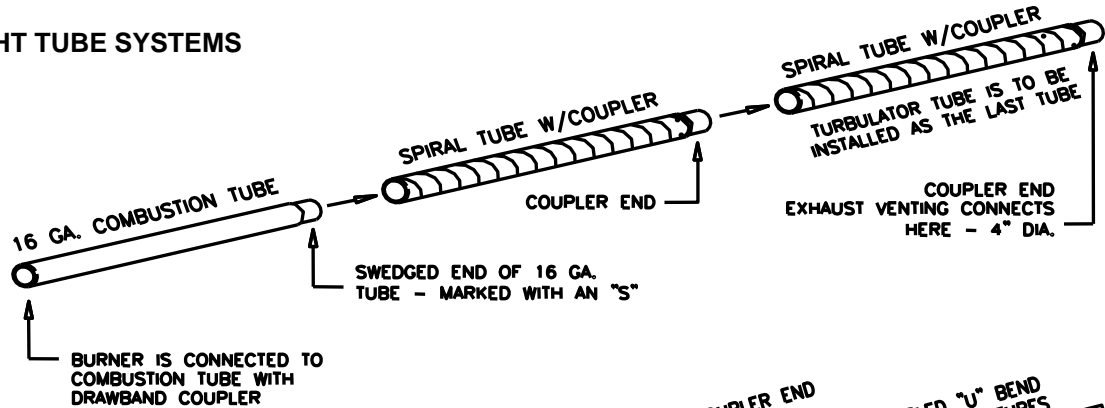



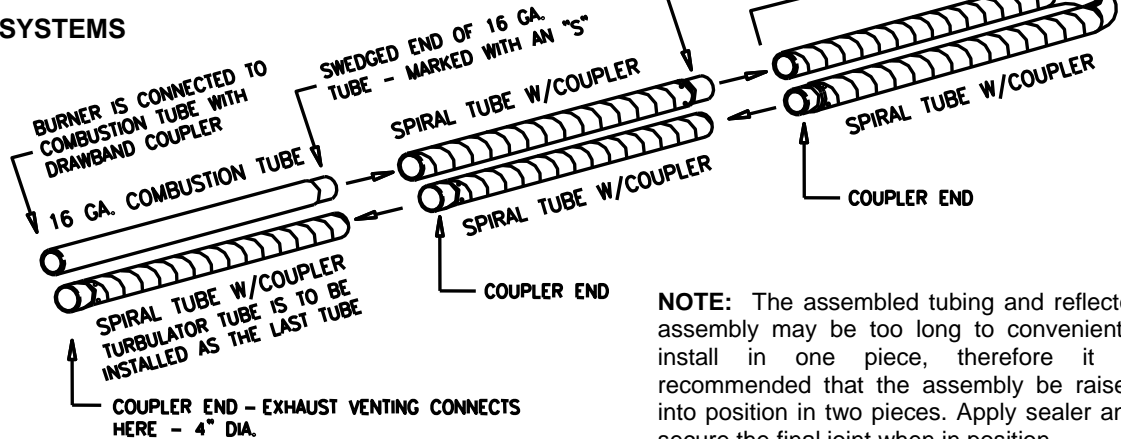

"U" TUBE SYSTEMS



NOTE: The assembled tubing and reflector assembly may be too long to conveniently install in one piece, therefore it is recommended that the assembly be raised into position in two pieces. Apply sealer and secure the final joint when in position.

3.5" STRAIGHT TUBE SYSTEM

-  - TURBULATOR
-  - BURNER END
-  - HANGER
-  - REFLECTOR SUPPORT
-  - REFLECTOR EXPANSION JOINT

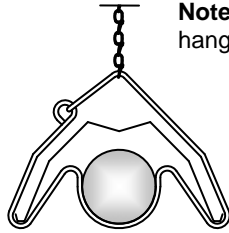

Note: Install Reflector inside hanger as shown.

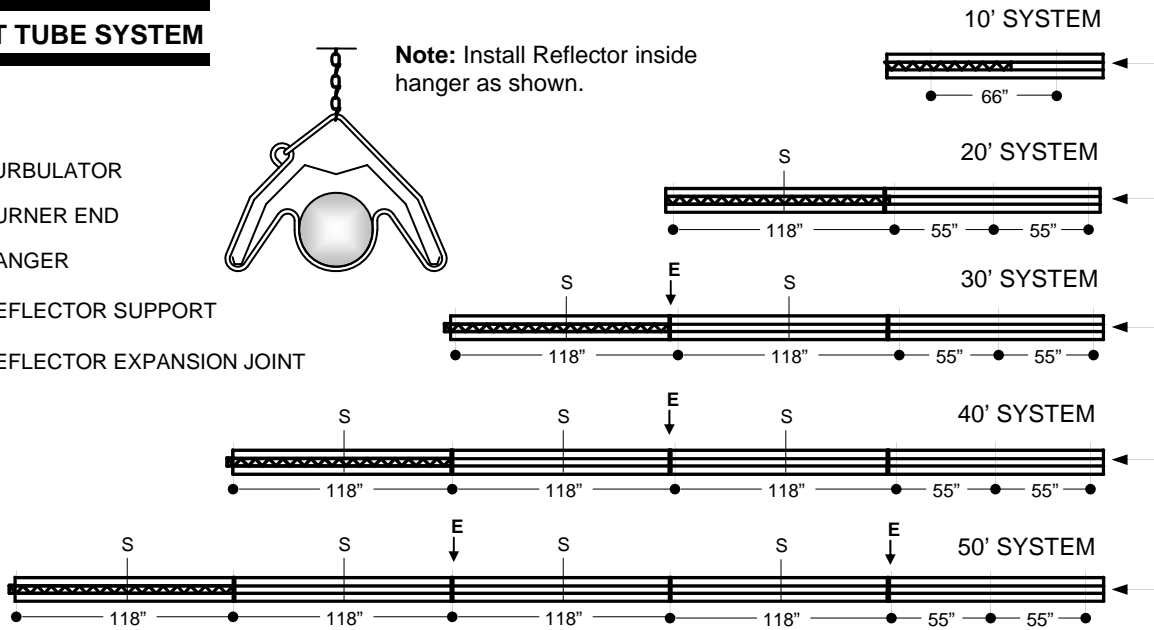

4.0" STRAIGHT TUBE SYSTEM

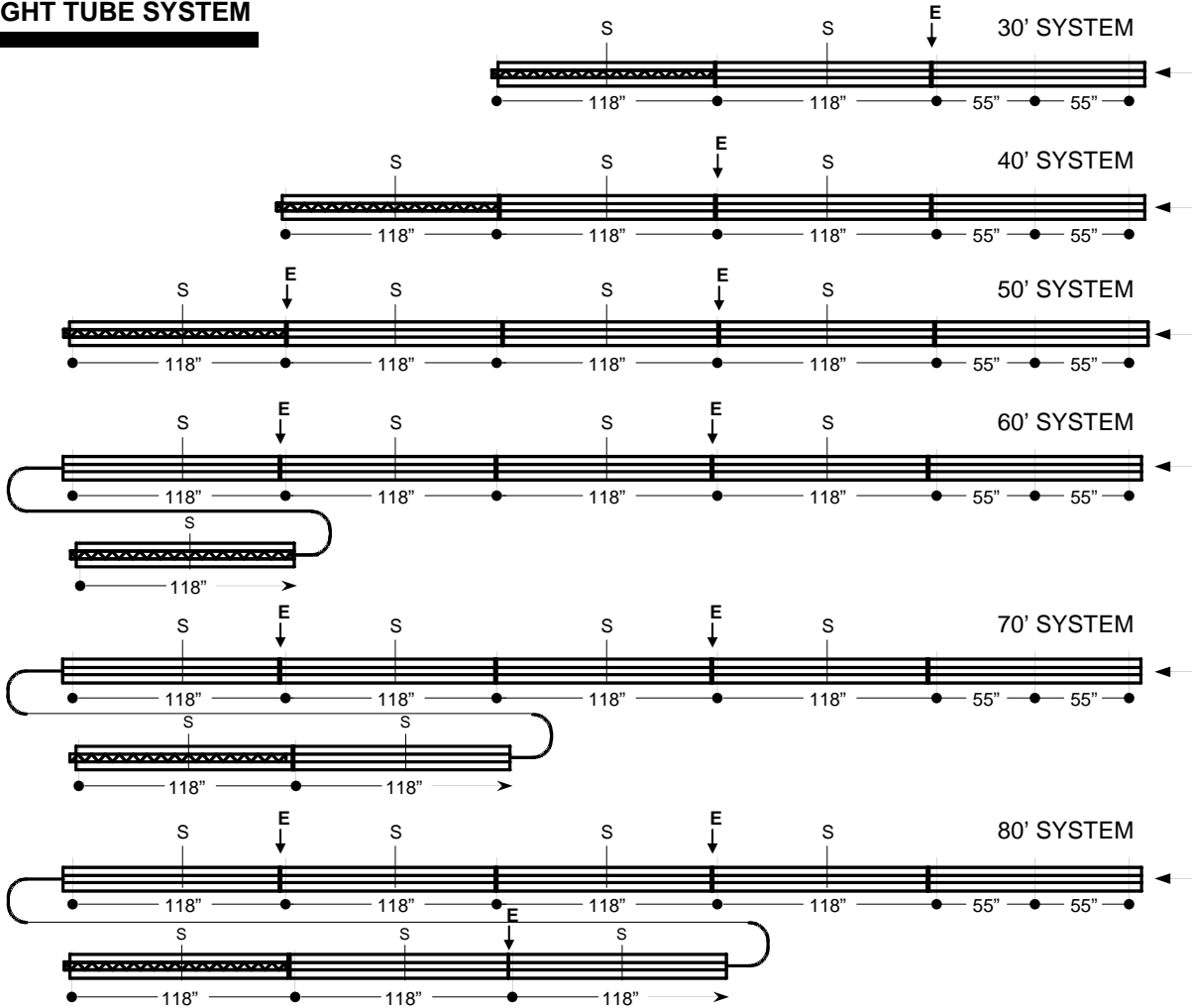

IMPORTANT: A reflector expansion joint (unsecured reflectors) at every other overlap is required for expansion and contraction of the system. Failure to do so will result in reflectors buckling and system noise!

3.5" "U" TUBE SYSTEM

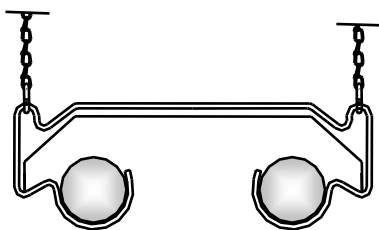
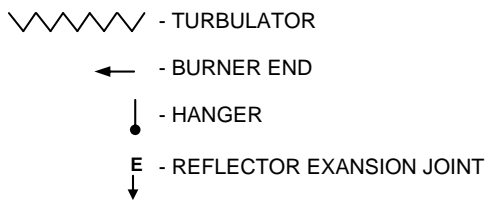

Note: Install Reflector inside hanger as shown.

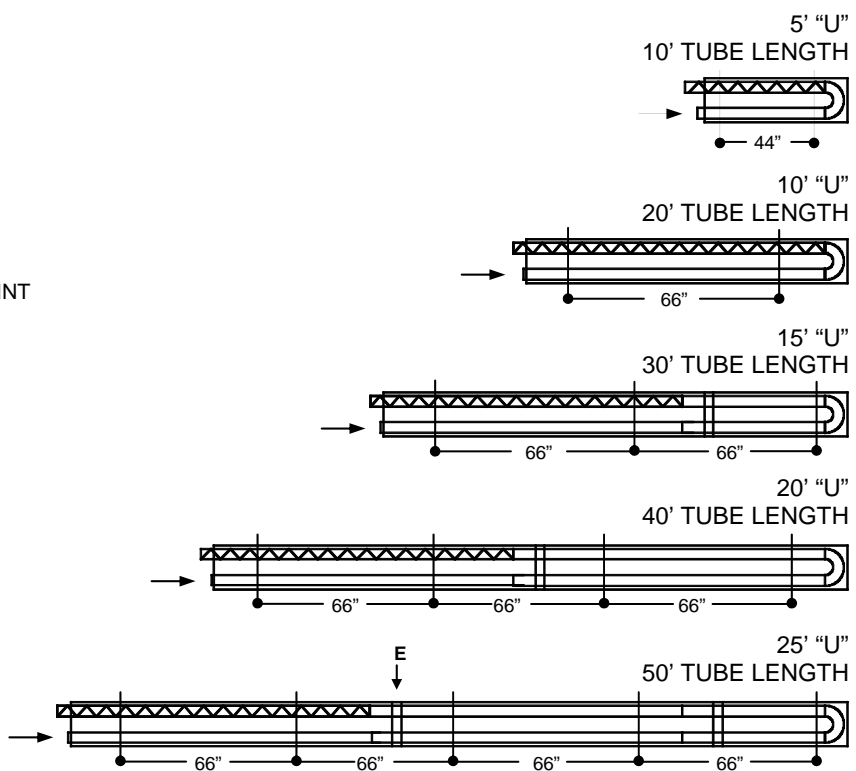

4.0" "U" TUBE SYSTEM

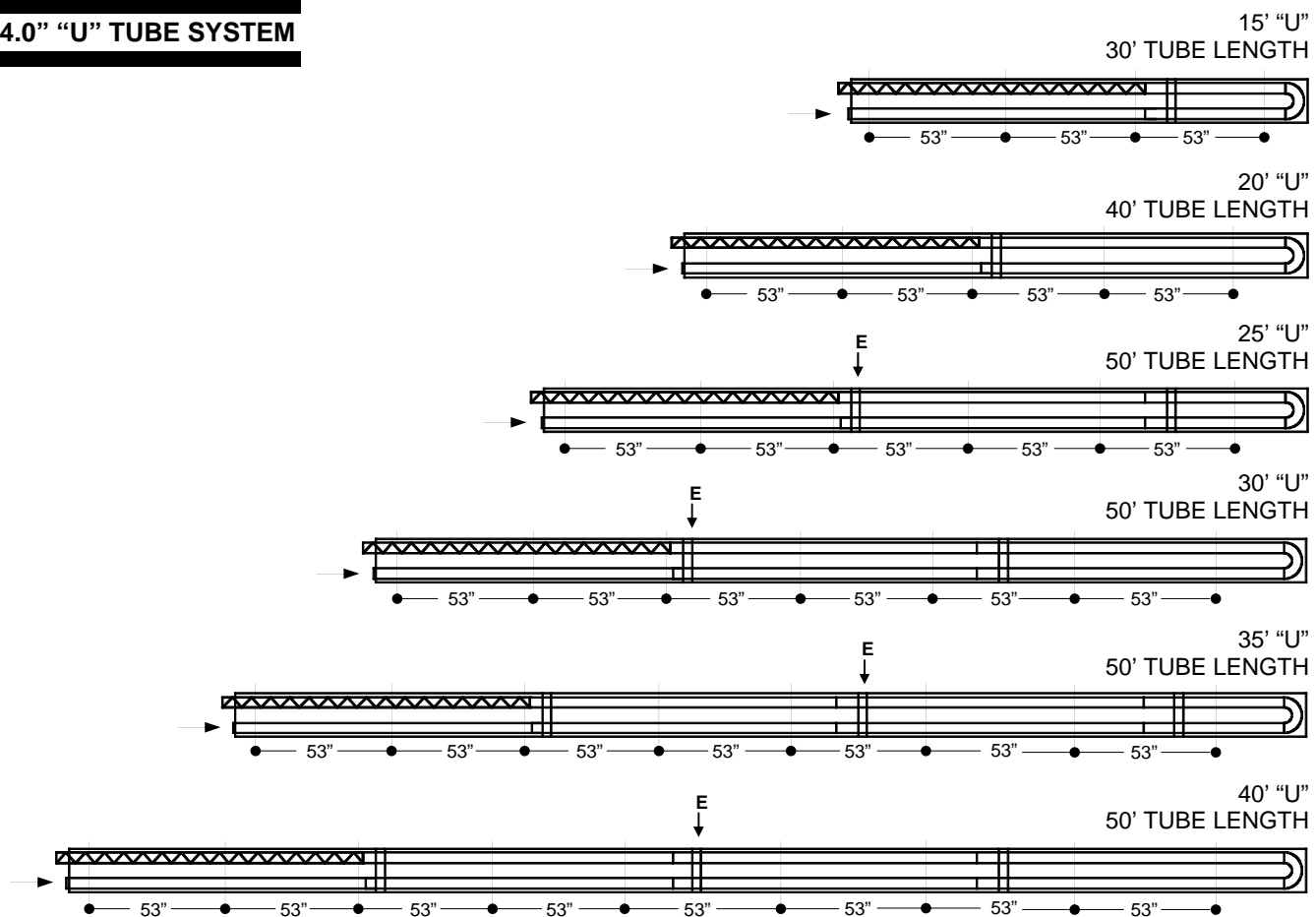

IMPORTANT: A reflector expansion joint (unsecured reflectors) at every other overlap is required for expansion and contraction of the system. Failure to do so will result in reflectors buckling and system noise!

SUSPENSION

! WARNING

COLLAPSE, FIRE AND EXPLOSION HAZARD



Improper suspension of the tube heater may result in collapse and being crushed. Always suspend from a permanent and secure part of the building structure that can evenly support the total force and weight of entire the heating system.

Failure to maintain minimum clearance to combustibles may result in fire and/or explosion, property damage, serious injury or death. Always maintain minimum clearances and post clearance signs where needed.

Combustion Research Corporation recommends that *Omega II*® systems are hung by means of chain. Chain and "S" hooks are supplied as an option. **DO NOT**

STRETCH OR INSTALL CHAIN OTHER THAN IN A VERTICAL FASHION WHEN INITIALLY INSTALLED (BURNER NOT FIRING).

If chain is not supplied by Combustion Research Corp., furnish a chain with a minimum 90 lb. workload (trade size #3 or larger). A minimum of 12" (30 cm) of hanging chain is recommended. This allows for system expansion and contraction, reducing the likelihood of reflector and radiant tube warping and/or expansion noise.

CAUTION: Infrared tube systems expand and contract upon each call for heat. System expansion of up to 4" can be expected.

Provisions must be made to limit lateral movement when systems are installed in site conditions where open doors may create a wind condition – see page 8 for guidelines.

Radiant tubes **DO NOT** require sloping.

For fine adjustment turnbuckles may be used.

NOTES:

- SECURE TURNBUCKLES SO THAT THEY WILL NOT UNWIND OR UN-SCREW.
- CRIMP "S" HOOKS CLOSED BEFORE LEAVING JOB. REFLECTORS ARE NOT TO BE INSTALLED ON TOP OF COMBINATION HANGER

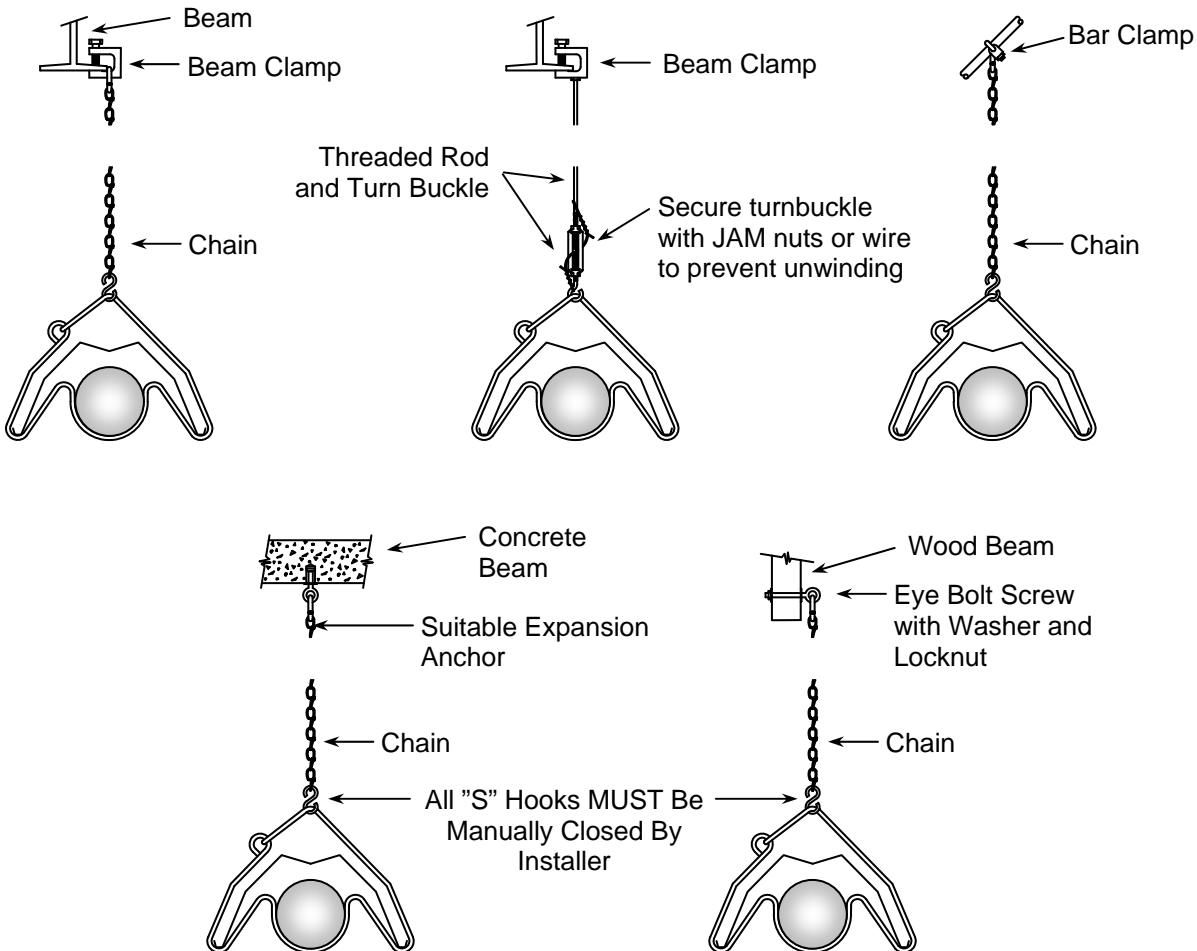

COMBUSTION TUBE INSTALLATION

The first section or radiant tube downstream of the burner is a heavy wall 16 Ga. heat-treated aluminized steel tube. This tube is referred to as the combustion tube. One end of this tube is swaged to fit inside the next spiral radiant tube. The end that is un-swaged is coupled to the burner

assembly – see page 9. It is necessary that the weld seam on this combustion tube be positioned so that it is on the bottom when installed.

This applies for both straight tube and “U” tube systems. When the systems are mounted on a 30° angle the weld seam should always be on the bottom.

Install Combustion Tube
with Weld Seam On Bottom

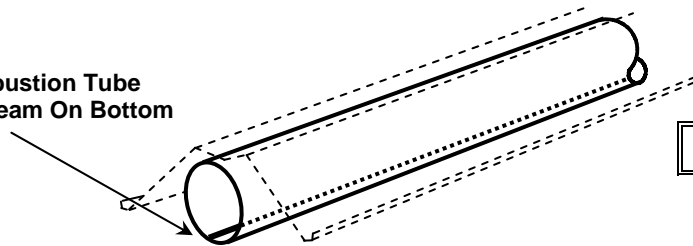

! IMPORTANT !

TUBE & REFLECTOR HANGING METHODS

The Omega II® system reflectors can be suspended horizontally or at a 30° angle. The combination hanger is designed so that the reflector angle will be horizontal when

suspended from the top loop or at a 30° angle when suspended from the offset loop – see the illustration below.

The panel hangers may also be suspended horizontally or at a 30° angle – see illustration below.

Horizontal Mounting With
“Combination” Hanger

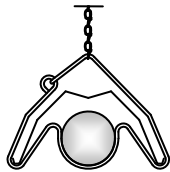

30° Mounting With
“Combination” Hanger



Horizontal Mounting With
“Panel” Hanger

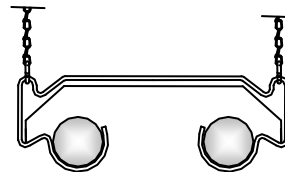

30° Mounting With “Panel”
Hanger

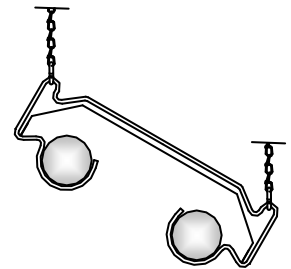

CUSTOMIZING SYSTEMS

A maximum of two 90° or four 45° elbows may be installed after THE SECOND tube. The tube couplers that have been factory installed will have to be removed to accommodate the installation of any elbows. Any additional elbows, radiant tube and reflector is optional equipment.

DO NOT INSTALL OR JAM TURBULATORS IN ELBOWS OR “U” BENDS. CONSULT YOUR REPRESENTATIVE OR THE FACTORY FOR PROPER INSTALLATION & GUIDANCE.

Reflector Elbow

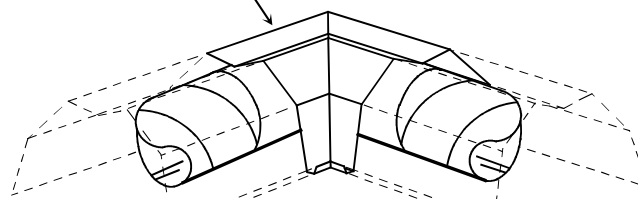

Secure To Connecting Reflector
With Sheet Metal Screws

SEISMIC RESTRAINT SUSPENSION METHODS

For standard seismic restraint such as earthquake prone areas, install seismic restraint chain or cable as shown below. If high winds can be encountered in the building, such as found in airplane hangers where opposing doors are simultaneously open, or system is installed near or below the door opening, additional support of the radiant

tube and reflector network will be required. See the "Seismic Suspension For High Wind Applications" below for details. If there are any questions regarding what method is best suited for your application consult your sales representative or contact the factory. If the system is a straight system (no elbows or tee's), apply an anti sway chain or wire rope which is parallel to the radiant tube at approximately the middle of the run.

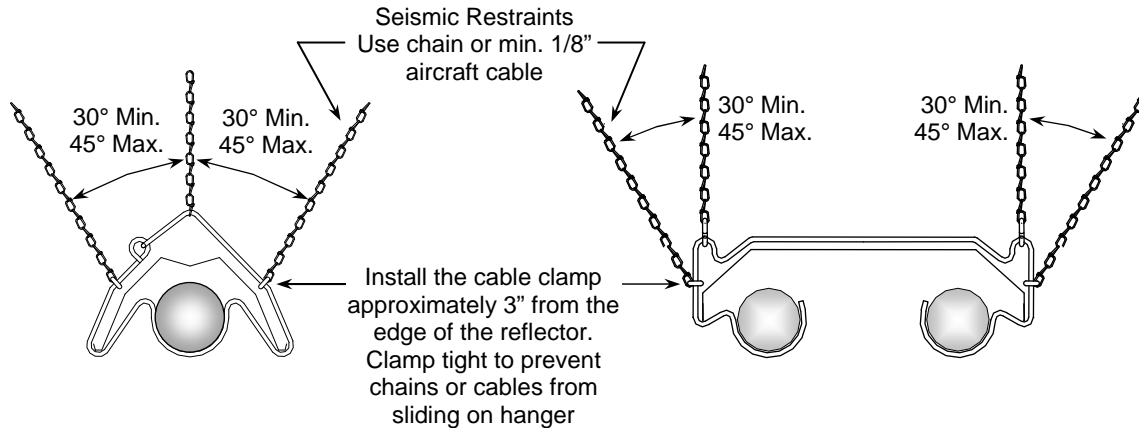

SEISMIC RESTRAINT FOR HIGH WIND APPLICATION

In high wind conditions it is recommended that seismic restraints and reflector retention wire be installed. See details below for recommended installation of seismic restraint and anti sway retention chains (wire rope). The vertical threaded rod shall be attached and suspend the reflector hangers at intervals of eight to ten feet (8' - 10'). At least one vertical threaded rod shall be placed at every elbow and/or tee connection. The threaded rod is used to

prevent the system from lifting during high wind conditions, the chain or wire rope will keep the system from swaying from side to side. When connecting threaded rod to "Z" purlin use beam clamp or drill a hole through "Z" purlin and secure with two 3/8" nuts and a lock washer. If the system is a straight system (no elbows or tee's), apply an anti sway chain or wire rope which is parallel to the radiant tube at approximately the middle of the run.

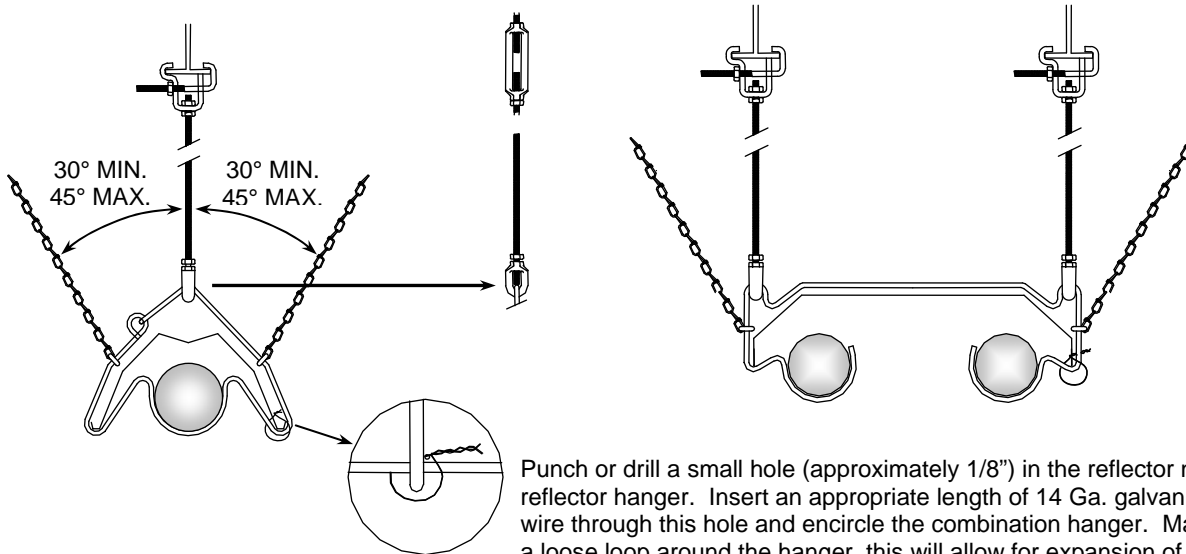

Punch or drill a small hole (approximately 1/8") in the reflector near the reflector hanger. Insert an appropriate length of 14 Ga. galvanized wire through this hole and encircle the combination hanger. Maintain a loose loop around the hanger, this will allow for expansion of the system. Twist the ends of the wire together and trim as required. This retention wire may be installed on either sides, or edges of the reflector for severe wind conditions.

CONNECTING BURNER ASSEMBLY TO RADIANT TUBE/REFLECTOR ASSEMBLY

! WARNING

FIRE OR EXPLOSION HAZARD



IMPROPER INSTALLATION, ADJUSTMENT, ALTERATION, SERVICE OR MAINTENANCE CAN CAUSE DEATH, SEVERE INJURY AND/OR PROPERTY DAMAGE.

There is expansion of the radiant pipe with each firing cycle and this will cause the burner to move with respect to the gas line. This can cause an unsafe condition if the gas pipe connection is not done in strict accordance to the instructions.

1. Remove the burner assembly from its shipping carton and using chain or threaded rod, hang the burner so that it butts up to the 16 Ga. tube of the tubing and reflector assembly, and connect the two with the draw band coupler provided. **IMPORTANT NOTE - THE WELD SEAM OF THE 16GA. TUBE MUST BE POSITIONED SO THAT IT IS ON THE BOTTOM.** Position draw band bolting assembly on the **TOP SIDE** of the tube assembly as shown - **DO NOT APPLY SEALER TO THE DRAW- BAND COUPLER.** After tightening the coupler, check to make sure the burner is lined up squarely - reposition as may be required, and re-tighten the draw band coupler. Secure with 2 sheet metal screws. See illustration below. Install reflector end cap at the burner end of the reflector. Fasten to reflector with sheet metal screws.

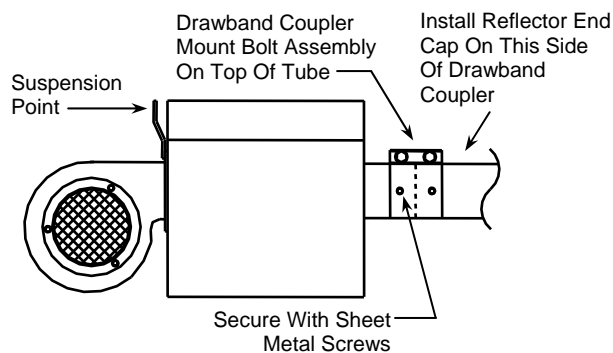

2. Connect the thermostat, gas and electrical supplies and hook up the exhaust flue and combustion air supply as it outlined in this manual.

3. The system is now ready to be fired. Refer to the START UP section of this manual.

NOTES: Heater must be independently supported and not rely on the gas or electrical line for any of its support. If there is not a convenient point for suspending the hanging chain above the heater DO NOT try to "stretch" the span by having severe angles on the chain. Rather build a bridge between the existing building structure using Angle

Iron, Uni-strut, etc. and then suspend the chain so that it hangs vertically.

! WARNING

FIRE OR EXPLOSION HAZARD



IMPROPER INSTALLATION, ADJUSTMENT, ALTERATION, SERVICE OR MAINTENANCE CAN CAUSE DEATH, SEVERE INJURY AND/OR PROPERTY DAMAGE.

To insure proper burner performance the burner head assembly **MUST** be mounted vertically even when tube and reflector assembly is angle mounted. Failure to do so may result in erratic pressure switch operation.

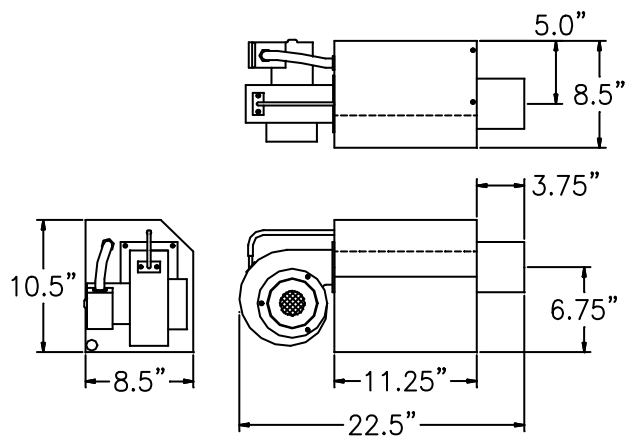

NOTE: On "U" tube systems, install exhaust end of radiant tube preferably on the motor side of burner assembly. This will allow easy access to burner controls and is necessary for proper burner operation for un-vented systems.

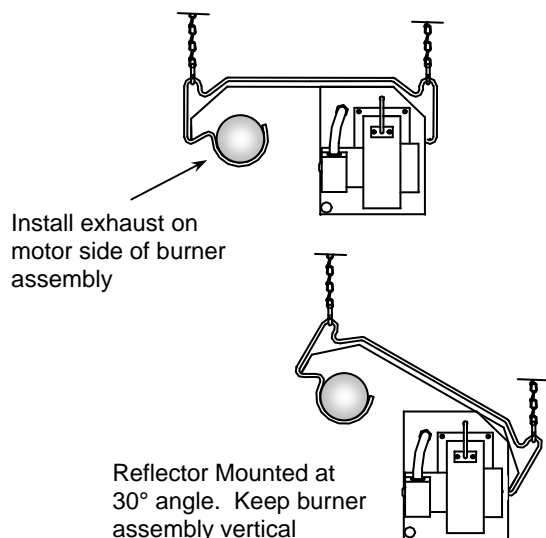

GAS SUPPLY

! WARNING

FIRE OR EXPLOSION HAZARD



IMPROPER INSTALLATION, ADJUSTMENT, ALTERATION, SERVICE OR MAINTENANCE CAN CAUSE DEATH, SEVERE INJURY AND/OR PROPERTY DAMAGE.

Follow these warnings exactly.

1. Disconnect power supply before wiring to prevent electrical shock or equipment damage.
2. To avoid dangerous accumulation of fuel gas, turn off gas supply at the appliance service valve before starting installation, and perform Gas Leak Test after completion of installation.
3. Always install sediment trap in gas supply line to prevent contamination of gas control.

Meter and service must be large enough to handle all the burners being installed plus any other connected load. When gas piping is not included in the layout drawing, the local gas supplier will usually help in planning the gas piping.

- ◆ Support all gas piping with suitable suspension materials and in accordance with local codes
- ◆ Use wrought iron or wrought steel pipe and malleable iron fittings. All pipe and fittings should be new and free from defects. Ream the pipe ends and tubing ends to remove obstructions and burrs.
- ◆ Use LP-gas resistant joint compound on all threads. Apply only to male end of piping.

Check all piping, fittings and connections for leaks before placing heating equipment into service. Use only soap and water solution for checking for gas leaks, NEVER use and open flame.

In industrial installations where the natural gas pressure at the meter is available at higher pressure than the standard 7" TO 14" W.C., it may be possible to cut down on gas piping costs (when local codes and the Fire Marshal approve) by running high pressure gas lines inside the building or on the outside of the building. In no case should the pressure exceed 10% of the service supply pressure. When using a high pressure gas distribution system each heating zone should be equipped with a pounds to inches service regulator with soft seat, positive 100% lock-up.

Allowing high gas pressure on the downstream side of the regulator will damage the control valve in the gas train. The outlet pressure of the service regulators should be set at 7" W.C. for natural gas and 11" W.C. for LP gases/propane gases. If it is not practical to regulate in "zones", each burner may be equipped with its own regulator.

To meet the requirements of 100% positive lock-up and internal relief vent must be piped to the outside of the building. It is recommended that an intermediate service regulator, such as a Maxitrol 325 Series or approved equal be used.

The typical discharge pressure on the down stream side of the gas meter furnished by the gas company is usually 5 P.S.I.G. while the discharge pressure of the regulator on the propane tank is usually set at 15 P.S.I.G.

Proper sizing of low and high pressure piping distribution systems for natural gas should be made in accordance with the National Fuel Gas Code, ANSI Z223.1 (current standard) NFPA No. 54. Consult the supplier of the propane tank and vaporizing system for the sizing of the piping system for LP gas pipe work.

When leak testing the gas piping system, the Omega II® burners must be isolated from the gas piping system. High-pressure compressed air used in the leak test will damage the control valve in the burner gas train, which will result in unsafe operation of the burner(s). For proper and safe test procedures, observe the provisions of Part #4, of the National Fuel Gas Code, ANSI Z223.1 (current standard) - *Inspection, Testing and Purging* or refer to equivalent local. In Canadian see gas code CAN/CGA-B149.1- M91.

NOTE: It is important that the entire system, up to the burner gas connection, be checked for leaks, prior to start up.

GAS PIPE SIZING CHART

NATURAL GAS							
Pipe Size	Total Length of Pipe (feet)						
	20'	40'	60'	80'	100'	150'	200'
½"	120	82	66	57	50	40	35
¾"	250	170	138	118	103	84	72
1"	465	320	260	220	195	160	135
1-¼"	848	600	517	427	380	310	268
1-½"	1316	931	801	661	588	480	416
PIPE CAPACITY - MBTU/HR							
½" W.C. P.D. WITH 7.0" SUPPLY PRESSURE							

LP / PROPANE GAS							
Pipe Size	Total Length of Pipe (feet)						
	20'	40'	60'	80'	100'	150'	200'
½"	275	129	103	89	78	63	54
¾"	567	267	217	185	162	132	112
1"	1071	504	409	346	307	252	209
1-¼"	2205	1039	834	724	630	511	439
1-½"	3307	1559	1275	1086	976	787	665
PIPE CAPACITY - MBTU/HR							
½" W.C. P.D. WITH 11.0" SUPPLY PRESSURE							

FLEXIBLE GAS CONNECTOR

⚠ WARNING

FIRE OR EXPLOSION HAZARD



IMPROPER INSTALLATION, ADJUSTMENT, ALTERATION, SERVICE OR MAINTENANCE CAN CAUSE DEATH, SEVERE INJURY AND/OR PROPERTY DAMAGE.

There is expansion of the radiant pipe with each firing cycle and this will cause the burner to move with respect to the gas line. This can cause an unsafe condition if the gas pipe connection is not done in strict accordance to the instructions.

United States - Use only the stainless steel flexible gas connector as supplied by Combustion Research Corporation.

Canada – Use approved gas connector as outlined in B149 Codes; Type 1, minimum 36” long. See chart below for sizing. This hose is to be supplied by the Installer contractor.

Install the flex connector as shown in the diagram below. This gas connector accommodates the normal expansion of the system. Before connecting the gas connector verify that all high-pressure testing has been completed.

The gas connector shut off valve must be parallel to the gas inlet on the burner. A 2” (5cm) cold displacement for initial setup is shown. This displacement may reduce when the system is fired.

- Do not high pressure test the gas piping with the burner connected. Failure to follow these instructions can result in property damage.
- Check the pipe and tubing ends for leaks before placing heating equipment into service. When checking for gas leaks, use a soap and water solution, never use an open flame. The loop of the gas flex **MUST BE** parallel or in line with the gas inlet pipe on the burner.
- The displacement as shown is for cold, non-firing condition. This displacement will vary as system heats up.
- Install drip leg in accordance with all applicable codes.
- **EXCESSIVE TORQUE ON THE BURNER GAS INLET MANIFOLD MAY CAUSE DAMAGE. ALWAYS USE TWO (2) WRENCHES WHEN MAKING PIPING CONNECTIONS TO THE BURNER. DO NOT APPLY PIPE DOPE TO FLARE NUT FITTINGS OF THE FLEXIBLE GAS CONNECTOR.**

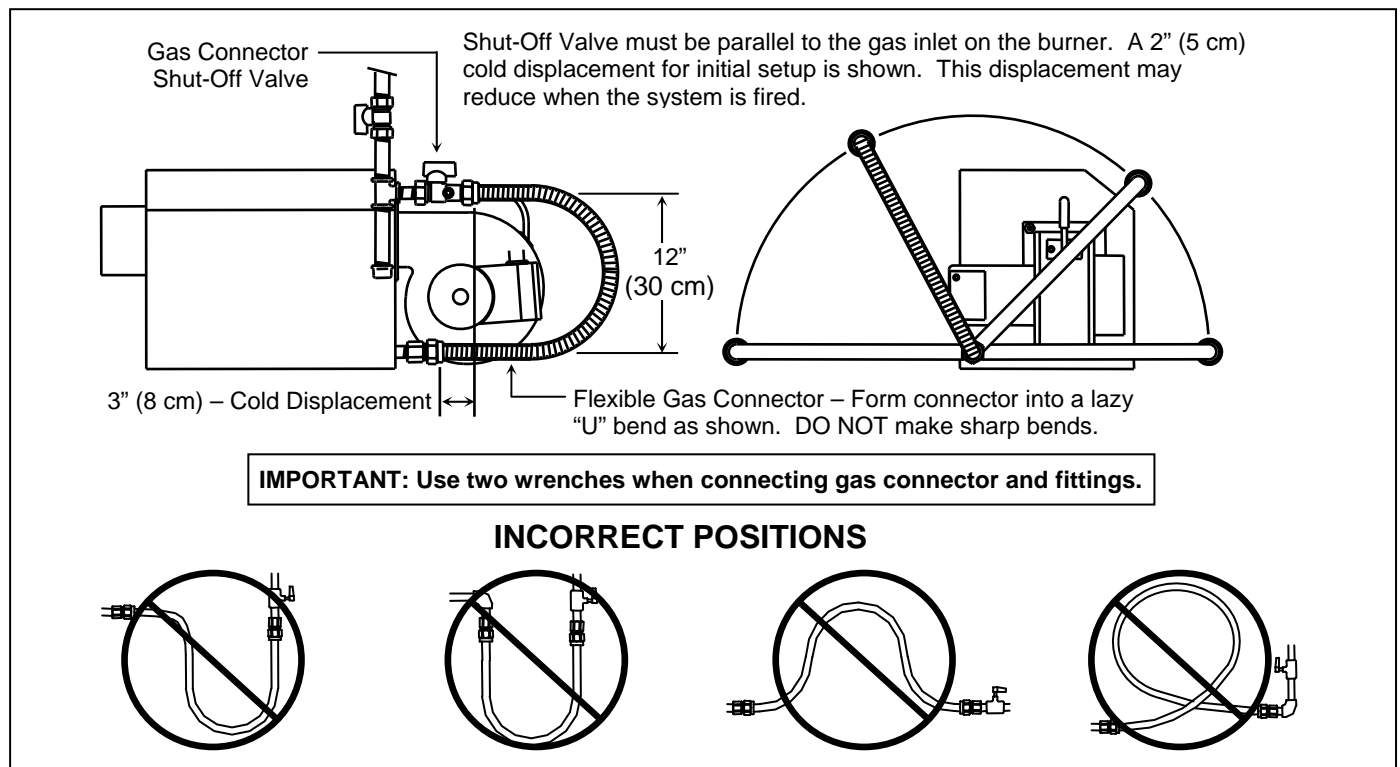

Gas Connector Description	Used With Inputs of	P/N
½” Flexible Stainless Steel Gas Connector (US Models) – 36” L	40K through 150K	0317.01
¾” Flexible Stainless Steel Gas Connector (US Models) – 36” L	155K through 200K	0417.00
½” Flexible Type 1 Rubber Hose (Canada Only) – 36” L	40K through 175K	Supplied by Installer
¾” Flexible Type 1 Rubber Hose (Canada Only) – 36” L	180K through 200K	Supplied by Installer

GAS PRESSURE AT MANIFOLD

Natural Gas: 3.5" W.C.
 LP Gas: 10.0" W.C.
 1/2" NPT Gas Connector Size

ELECTRICAL RATING

115VAC, 60 Hz., 1.8 Amp

GAS INLET PRESSURE

Natural Gas: 6.0" W.C. Minimum 14.0"W.C. Maximum
 LP Gas: 11.0" W.C. Minimum 14.0" W.C. Maximum

ALTITUDE

Systems 0922 through 0910 (40k - 100k Btu/hr input)
 0 - 4,500 Ft. **(0 - 1370 m)** No de-rating required.
 Systems 0926 through 0945 (105k - 200k Btu/hr input)
 0 - 2,000 Ft. **(0 - 610 m)** No de-rating required
 2,000 - 4,500 Ft. **(610 - 1,370m)** De-rating required.

HONEYWELL GAS VALVE

PN 5285.06 (NG) & 5285.06LP (LP)

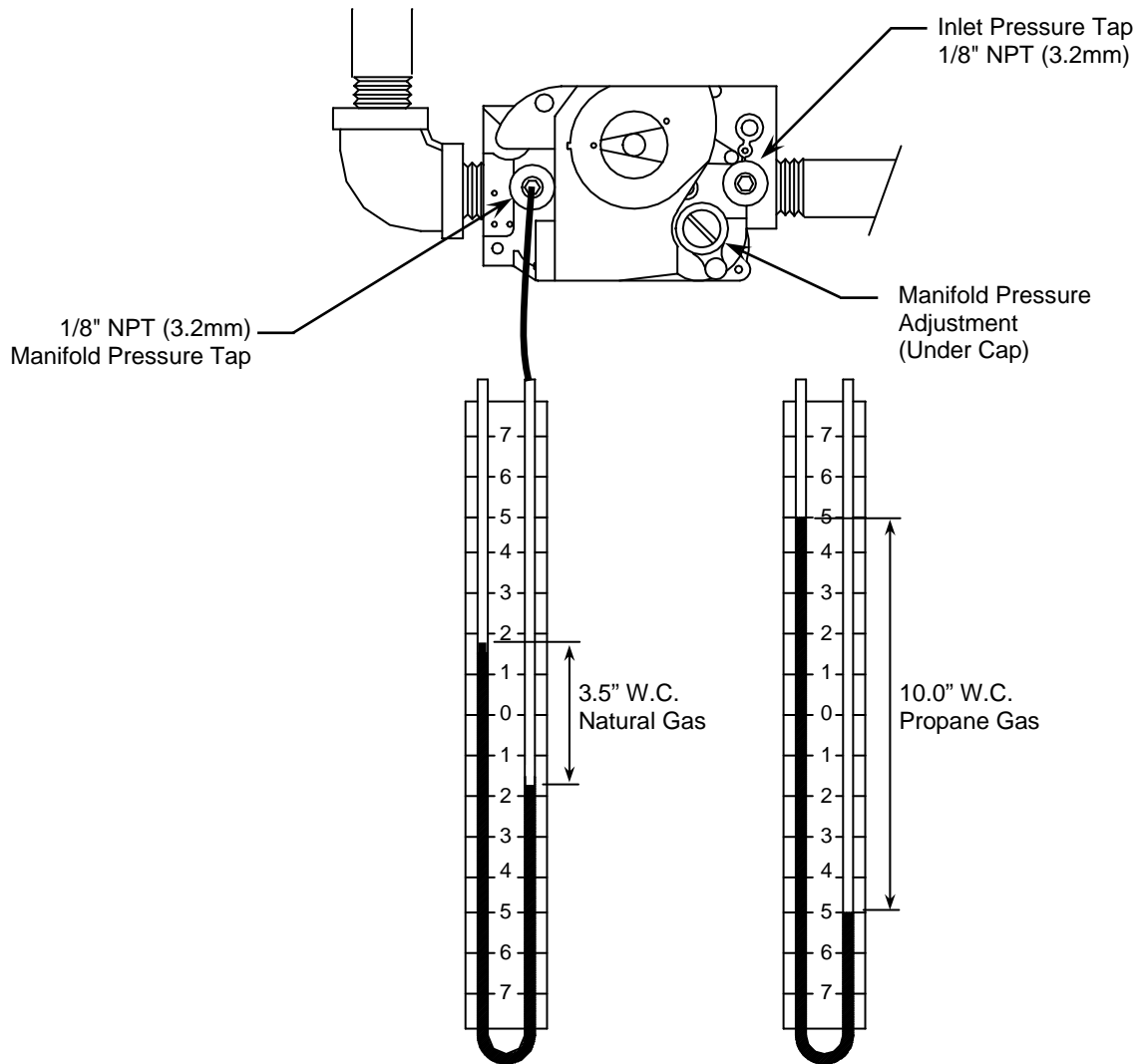

NOTE: Gas pressures must be measured with a water or red oil manometer - NOT A DIAL GAUGE. All measurements must be made when this heater and all other gas burning equipment connected to the gas supply system are operating at maximum capacity. It should be assured by test that the gas pressure at the burner inlet is not greater than the figures given above. Maximum inlet pressure is 1/2 lb. or 14.0" W.C.

The installer must provide a 1/8" N.P.T. (3.2mm) plugged tapping, accessible for test gauge connection, immediately upstream of the gas supply.

3.5" OMEGA II®

PART NUMBER	BTU/Hr INPUT	A ("U" TUBE SYSTEM)	B (STRAIGHT TUBE SYSTEM)	SQ. FT. RADIANT SURFACE AREA
0922.NG/LP	40,000	5'0"/10'0"	10'0"/19'8"	9.2 / 18.3
0921.NG/LP	45,000	5'0"/10'0"	10'0"/19'8"	9.2 / 18.3
0920.NG/LP	50,000	10'0" / 14'8"	19'8" / 29'10"	18.3 / 27.5
0919.NG/LP	55,000	10'0" / 14'8"	19'8" / 29'10"	18.3 / 27.5
0918.NG/LP	60,000	10'0" / 14'8"	19'8" / 29'10"	18.3 / 27.5
0917.NG/LP	65,000	10'0" / 14'8" / 19'11"	19'8" / 29'10" / 39'4"	18.3 / 27.5 / 36.2
0916.NG/LP	70,000	10'0" / 14'8" / 19'11"	19'8" / 29'10" / 39'4"	18.3 / 27.5 / 36.2
0915.NG/LP	75,000	10'0" / 14'8" / 19'11"	19'8" / 29'10" / 39'4"	18.3 / 27.5 / 36.2
0914.NG/LP	80,000	10'0" / 14'8" / 19'11"	19'8" / 29'10" / 39'4"	18.3 / 27.5 / 36.2
0913.NG/LP	85,000	10'0" / 14'8" / 19'11"	19'8" / 29'10" / 39'4"	18.3 / 27.5 / 36.2
0912.NG/LP	90,000	10'0" / 14'8" / 19'11"	19'8" / 29'10" / 39'4"	18.3 / 27.5 / 36.2
0911.NG/LP	95,000	14'8" / 19'8" / 24'10"	29'10" / 39'4" / 49'1"	27.5 / 36.2 / 45.1
0910.NG/LP	100,000	14'8" / 19'8" / 24'10"	29'10" / 39'4" / 49'1"	27.5 / 36.2 / 45.1

4" OMEGA II®

BURNER PART NUMBER	BTU/Hr INPUT	A ("U" TUBE SYSTEM)	B (STRAIGHT TUBE SYSTEM)	SQ. FT. RADIANT SURFACE AREA
0926.NG/LP	105,000	14'8" / 19'11" / 24'9"	29'10" / 39'4" / 49'1"	31.2 / 41.1 / 51.2
0927.NG/LP	110,000	14'8" / 19'11" / 24'9"	29'10" / 39'4" / 49'1"	31.2 / 41.1 / 51.2
0928.NG/LP	115,000	14'8" / 19'11" / 24'9"	29'10" / 39'4" / 49'1"	31.2 / 41.1 / 51.2
0929.NG/LP	120,000	19'11" / 24'9" / 29'9"	39'4" / 49'1" / 58'11"	41.1 / 51.2 / 61.7
0930.NG/LP	125,000	19'11" / 24'9" / 29'9"	39'4" / 49'1" / 58'11"	41.1 / 51.2 / 61.7
0931.NG/LP	130,000	19'11" / 24'9" / 29'9"	39'4" / 49'1" / 58'11"	41.1 / 51.2 / 61.7
0932.NG/LP	135,000	19'11" / 24'9" / 29'9"	39'4" / 49'1" / 58'11"	41.1 / 51.2 / 61.7
0933.NG/LP	140,000	19'11" / 24'9" / 29'9"	39'4" / 49'1" / 58'11"	41.1 / 51.2 / 61.7
0934.NG/LP	145,000	19'11" / 24'9" / 29'9"	39'4" / 49'1" / 58'11"	41.1 / 51.2 / 61.7
0935.NG/LP	150,000	19'11" / 24'9" / 29'9"	39'4" / 49'1" / 58'11"	41.1 / 51.2 / 61.7
0936.NG/LP	155,000	19'11" / 24'9" / 29'9" / 34'9"	39'4" / 49'1" / 58'11" / 68'8"	41.1 / 51.2 / 61.7 / 71.8
0937.NG/LP	160,000	19'11" / 24'9" / 29'9" / 34'9"	39'4" / 49'1" / 58'11" / 68'8"	41.1 / 51.2 / 61.7 / 71.8
0938.NG/LP	165,000	19'11" / 24'9" / 29'9" / 34'9"	39'4" / 49'1" / 58'11" / 68'8"	41.1 / 51.2 / 61.7 / 71.8
0939.NG/LP	170,000	19'11" / 24'9" / 29'9" / 34'9"	39'4" / 49'1" / 58'11" / 68'8"	41.1 / 51.2 / 61.7 / 71.8
0940.NG/LP	175,000	19'11" / 24'9" / 29'9" / 34'9"	39'4" / 49'1" / 58'11" / 68'8"	41.1 / 51.2 / 61.7 / 71.8
0941.NG/LP	180,000	24'9" / 29'9" / 34'9"	49'1" / 58'11" / 68'8"	51.2 / 61.7 / 71.8
0942.NG/LP	185,000	24'9" / 29'9" / 34'9"	49'1" / 58'11" / 68'8"	51.2 / 61.7 / 71.8
0943.NG/LP	190,000	24'9" / 29'9" / 34'9"	49'1" / 58'11" / 68'8"	51.2 / 61.7 / 71.8
0944.NG/LP	195,000	24'9" / 29'9" / 34'9" / 39'9"	49'1" / 58'11" / 68'8" / 78'5"	51.2 / 61.7 / 71.8 / 82
0945.NG/LP	200,000	24'9" / 29'9" / 34'9" / 39'9"	49'1" / 58'11" / 68'8" / 78'5"	51.2 / 61.7 / 71.8 / 82

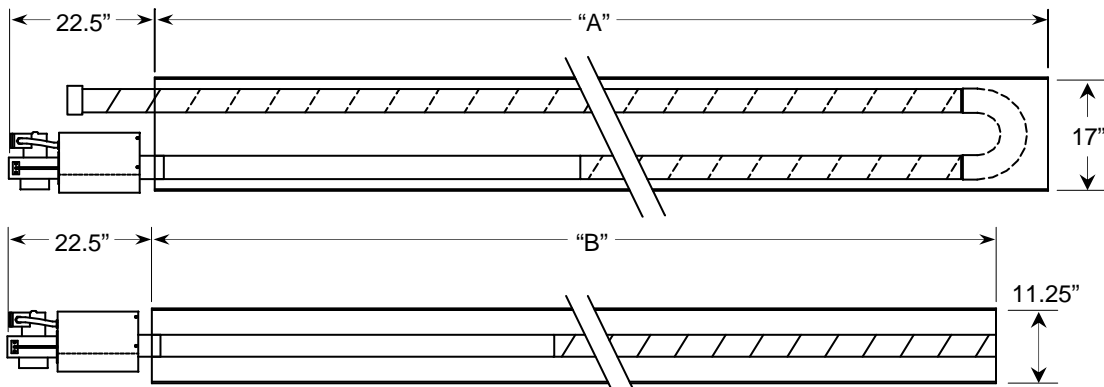

! WARNING



Placement of explosive objects, flammable objects, liquids and vapors close to the heater may result in fire, explosion, death and serious injury or property damage. Do not store or use explosive objects, liquids and vapor in the vicinity the heater.

In all situations the clearance to combustibles must be maintained. Failure to observe clearances to combustibles will result in death, serious injury, or property damage. **In storage areas where stacking of materials may occur, the installer must provide signs, which specify the maximum stacking height so as to maintain the required clearance to combustibles.** Minimum clearances must be maintained from vehicles parked, below the heater. Ensure that

adequate clearance is maintained where vehicles are in operation or being serviced. Consideration must be given when running the radiant tube next to wood, paper, storage racks, hoists, building construction, etc. For building personnel safety, the system shall not be mounted lower than 9' from the floor unless fitted with protective screens. The following illustrations and information give minimum acceptable clearance to combustibles.

Minimum clearances to combustibles must be maintained for wall, floor, ceiling temperatures. **The stated clearance to combustibles represents a surface temperature of 90°F (32°C) above room temperature. Building materials with a low heat tolerance (such as plastics, vinyl siding, canvas, tri-ply, etc.) may be subject to degradation at lower temperatures. It is the installer's responsibility to assure that adjacent materials are protected from degradation.**

Clearances must also be maintained from vehicles parked below as well as storage racks, partitions, hoists, building construction, etc

In storage areas where stacking of materials may occur, the installer must provide signs that specify the maximum stacking height so as to maintain the required clearance to combustibles. A temporary sign can be found at the end of this manual. Contact your sales representative or Combustion Research Corporation for this self adhesive label – P/N 5566.006.

UNVENTED END CLEARANCE

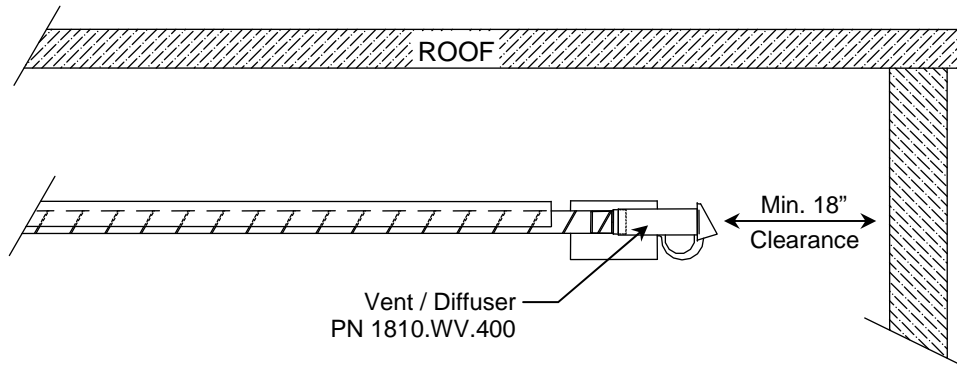

"U" BEND OR ELBOW END CLEARANCE

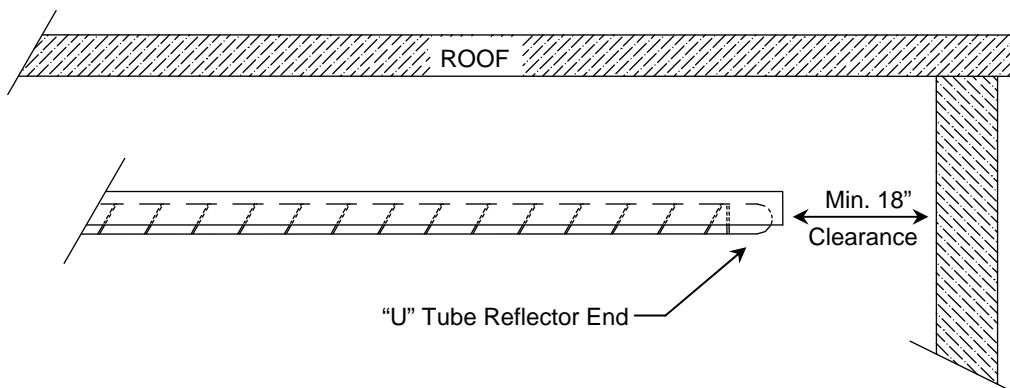

HORIZONTAL MOUNTING

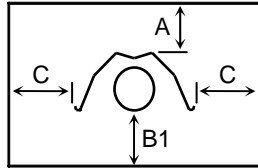

DEEP & STANDARD REFLECTOR

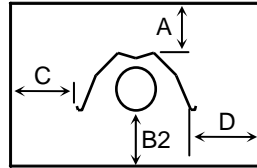

DEEP & STANDARD REFLECTOR WITH ONE SIDE SHIELD

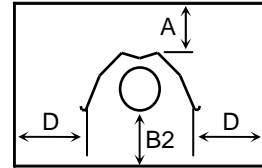

DEEP & STANDARD REFLECTOR WITH TWO SIDE SHIELD

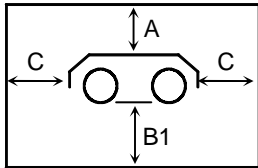

PANEL REFLECTOR

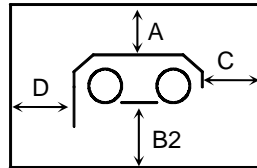

PANEL REFLECTOR WITH ONE SIDE SHIELD

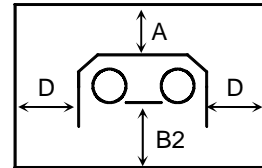

PANEL REFLECTOR WITH TWO SIDE SHIELD

30 DEGREE ANGLE MOUNTING

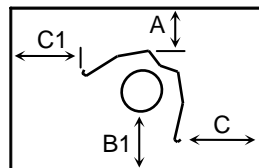

DEEP & STANDARD REFLECTOR

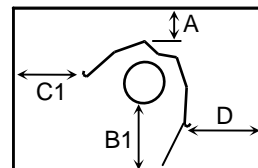

DEEP & STANDARD REFLECTOR WITH ONE SIDE SHIELD

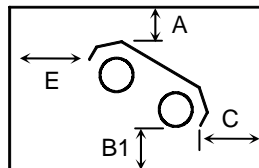

PANEL REFLECTOR

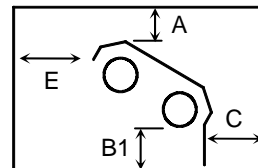

PANEL REFLECTOR WITH ONE SIDE SHIELD

20 FEET DOWN STREAM FROM BURNER

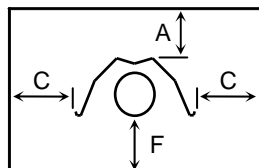

DEEP & STANDARD REFLECTOR

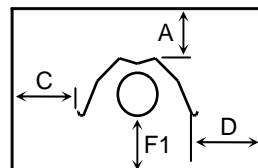

DEEP & STANDARD REFLECTOR WITH ONE SIDE SHIELD

PART NO.	BTU/HR	A	B1	B2	C	C1	D	D1	E	F	F1
0920 - 0922 NG/LP	40k to 50k	5"	44"	50"	12"	30"	12"	8"	30"	24"	30"
0919 - 0915 NG/LP	55k to 75k	5"	50"	57"	24"	36"	12"	8"	30"	24"	30"
0914 - 0910 NG/LP	80k to 100k	6"	60"	60"	32"	46"	12"	8"	40"	24"	30"
0926 - 0930 NG/LP	105k to 125k	6"	65"	70"	32"	38"	20"	24"	42"	40"	50"
0931 - 0935 NG/LP	130k to 150k	7"	65"	70"	42"	42"	20"	24"	42"	40"	50"
0936 - 0940 NG/LP	155k to 175k	7"	72"	72"	42"	42"	24"	38"	48"	44"	54"
0941 - 0945 NG/LP	180k to 200k	7"	80"	90"	48"	58"	24"	38"	48"	44"	54"

INSTALLATION PROCEDURE

The P/N 0366.00 side shield is used on the deep reflector. The PN 0367 side shield is designed for use on standard, and panel reflectors. This side shield may be installed on either side of the reflector. Refer to the layout plan and clearance to combustible chart on the preceding page for proper location.

Install one ten-foot side shield in conjunction with each ten foot section of reflector so that overlap joints align.

Cut a suitable relief notch for every reflector hanger and support.

The side shield is to be fastened to the reflector with #8 self drilling and tapping screws, one near each end and approximately one every two feet. The side shield expansion joint must match the reflector expansion joint. **DO NOT SCREW THE EXPANSION JOINTS TOGETHER.**

0363.00 REFLECTOR & 0366.00 SIDE SHIELD

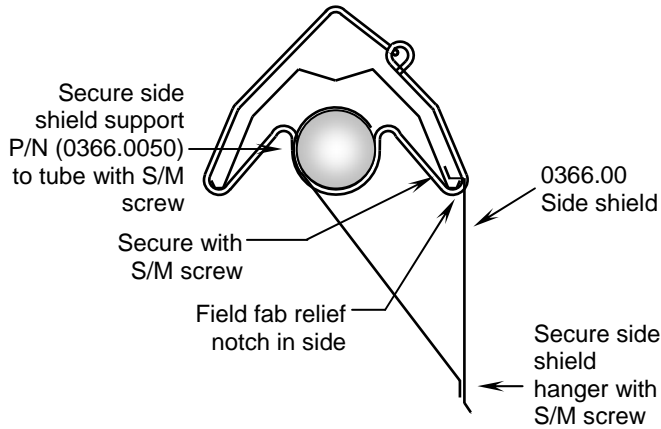

0812.00 REFLECTOR & 0367.00 SIDE SHIELD

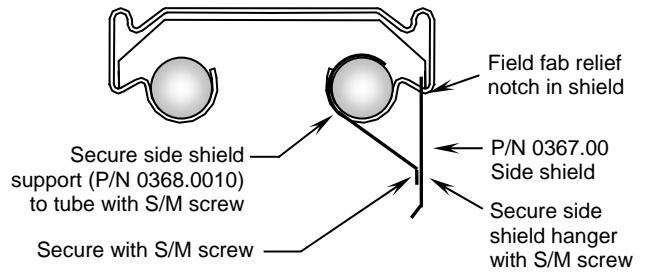

0360.00 REFLECTOR & 0367.00 SIDE SHIELD

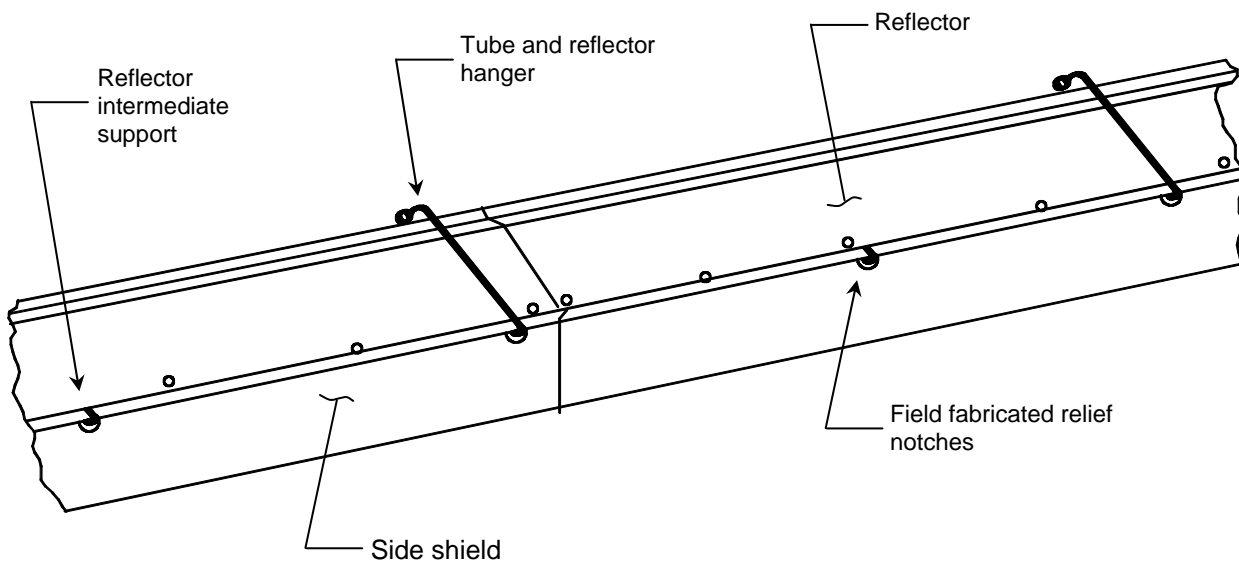
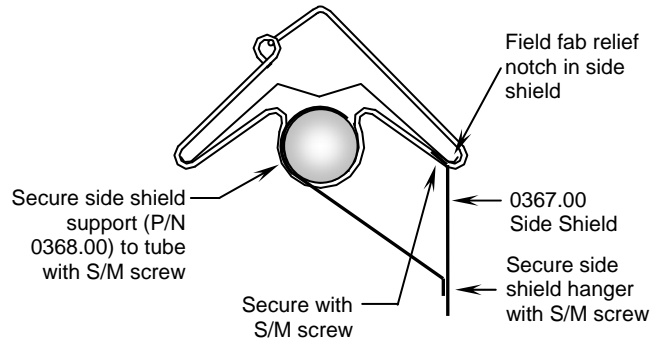

COMBUSTION AIR SUPPLY

NOTICE

Air that is not contaminated must be ducted to the heater if chlorinated or fluorinated contaminants, high humidity, other contaminants, or if negative pressure is present in the area where the heater is installed.

1. Combustion air is a factory preset opening.
2. It is recommended that outside combustion air be used. However, combustion air may be drawn from any space,

including the space that is being heated, PROVIDED the building does not have a negative pressure and the atmosphere is not contaminated with acid fumes, fluorocarbons, corrosive substances, dirt, oil, etc., which would have an adverse effect on the blower and radiant tubing. DO NOT draw combustion air be drawn from an attic space.

3. If outside air combustion air is not used and the room in which the heater is used is of a tight construction, provisions must be made for supplying combustion air. One square inch of free area opening for each 5,000 Btu/hr input is required to replenish the air used by the heating system.

SIDE WALL PENETRATION (TOP VIEW)

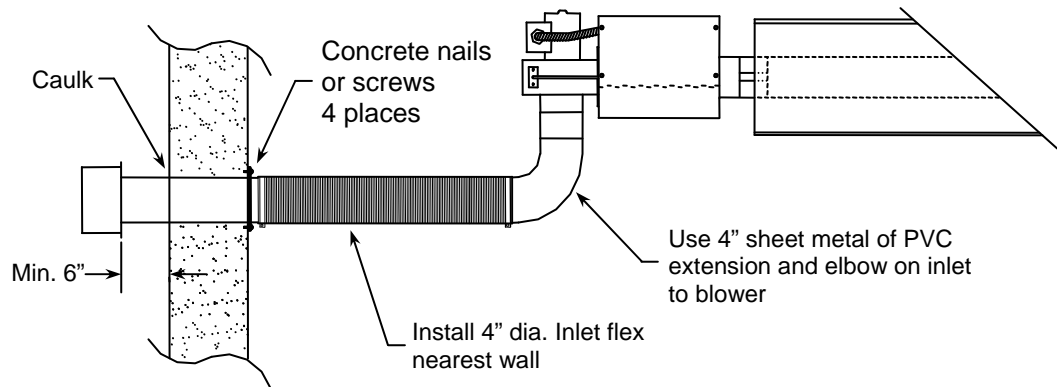

ROOF PENETRATION (SIDE VIEW)

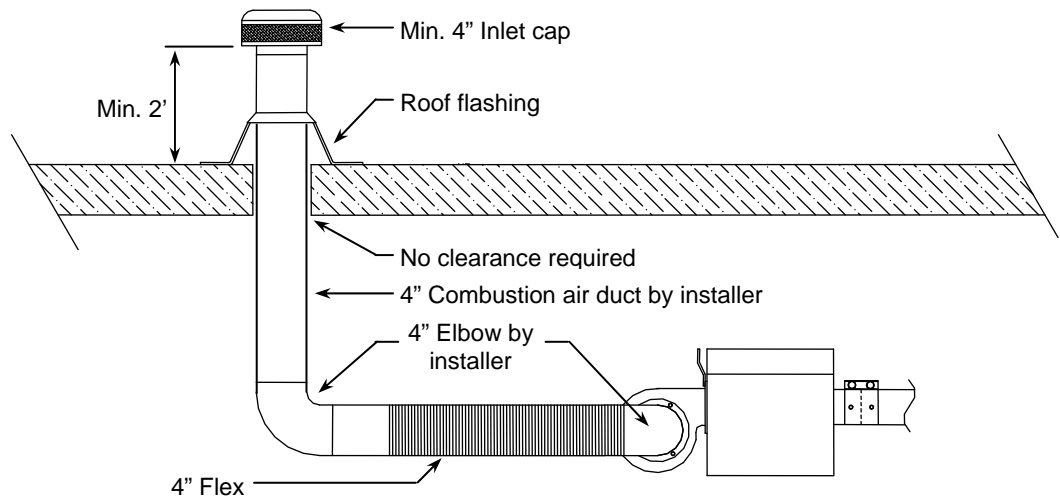

OUTSIDE AIR SUPPLY (RECOMMENDED)

1. The outside air intake assembly (PN 0314.00) consists of: 1 - 4" OD inlet hood, 1 - 4" OD 24" long inlet flex and 2 clamps.
2. The assembly may be extended by adding up to 20' of the appropriately sized ducting. A maximum of two elbows may be used. Insulating the ducting will stop condensation from forming on its exterior.
3. Air intake may be made through the roof using "mushroom" type vent cap.
4. Maintain a minimum of six (6') between the exhaust port and the fresh air inlet port.

5. Maintain a minimum of six inches (6") the inlet hood and the exterior wall.
6. DO NOT DRAW COMBUSTION AIR FROM ATTIC OR SIMILAR SPACE. DO NOT USE PLASTIC TYPE "DRYER" FLEX FOR THE COMBUSTION AIR INLET FLEX.
7. The air intake terminal must be located not less than one foot (1") above grade.

NOTE – Avoid installing inlet flex as an elbow into the blower and DO NOT install inlet flex as an elbow into the blower on burners with inputs of 155,000 Btu/hr and higher - system pulsation can occur.

OUTSIDE AIR SUPPLY

When two *OMEGA II*® systems are controlled by one thermostat a common combustion air supply can be used.

- This duct must be a minimum of six-inch (6") diameter and should not exceed fifty feet (50') in length.
- A Maximum of two (2) 90° elbows may be used.
- Maintain a minimum of six feet (6') between the exhaust port and the fresh air intake.

- Maintain a minimum of six inches (6") between the inlet hood and the exterior wall.
- Install 4" diameter flex nearest inlet trunk.
- Do not install inlet flex as an elbow into the blower on burners with inputs of 155,000 Btu/hr and higher - system pulsation can occur.

Air intake may be made through the roof using "mushroom" type vent cap.

Refer to the drawing below for a typical installation layout.

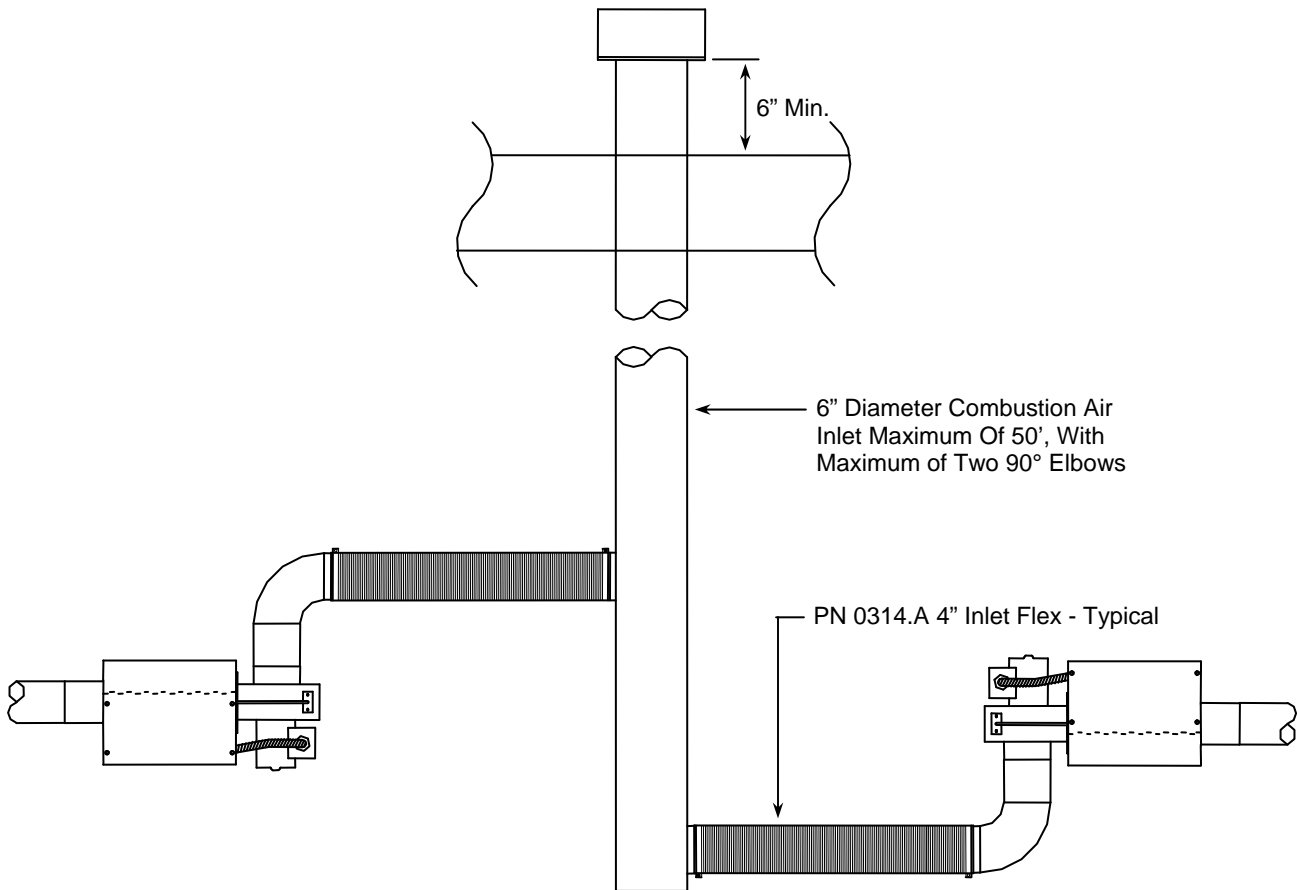

GENERAL NOTES

! WARNING



IMPROPER INSTALLATION CAN CAUSE DEATH, SEVERE INJURY AND/OR PROPERTY DAMAGE.

Improper venting and insufficient ventilation may result in health problems, carbon monoxide poisoning and death. Vent enclosed spaces and buildings according to national, state, provincial and local codes.

Heater vent must be installed in accordance with the National Fuel Gas Code, ANSI Z223.1 (current standard) (NFPA No. 54). Partial information pertaining to this specification is provided in this section with regard to size and configuration for various venting arrangements. Consult the ANSI Z223.1 (current standard) and any applicable local codes for complete information.

1. Make sure that the venting method selected is in compliance with any local codes.
 2. Heater exhaust end will receive a 4 inch diameter (single wall galvanized, aluminized or stainless steel) flue pipe.
 3. Heater may be vented to the outdoors vertically or horizontally. The vent piping shall be adequately supported to prevent sagging.
 4. Where the vent pipe passes through areas where the ambient temperature is likely to induce condensation of the flue gases the vent pipe shall be insulated.
 5. If the heater is to be vented horizontally:
 - a. Vent must terminate at least 3 feet (0.9m) above any Forced air inlet located within 10 feet (3.1m).
 - b. Vent shall terminate at least 4 feet (1.2m) below, 4 feet (1.2m) horizontally from, 1 foot (30cm) above any door, window or gravity air inlet into any building.
 - c. The bottom of the vent terminal shall be located at least 12" inches (30cm) above grade.
 6. Vent opening must be beyond any combustible overhang.
 7. Any portion of the flue pipe that passes through combustible material of the building must have a minimum 1" clearance and be dual insulated or use an approved thimble (refer to ANSI Z223.1 current standard)
- WALL THIMBLES**
 Combustion Research Corp. PN 1810.WT.400
 Hart & Cooley Metalvent PN 4RWT
8. Maximum flue length may be twenty feet (20') for all models.

9. If condensation within the flue becomes a problem, the flue should be shortened or insulated.

VENTING EQUIPMENT

VERTICAL VENTING

1. A four inch O.D. flue pipe is recommended. Maximum flue length may be twenty feet (20'). Do not use more than two (2) 90° elbows. Insulate as required to prevent condensation.
2. Use "B" vent for any roof penetration. Any vent pipe that passes through an attic or enclosed space must also be "B" vent.
3. A minimum 1" clearance around vent is required to pass through combustible materials (check local codes).
4. All Joints in the flue should be sealed. Use General Electric RTV 106 or Permatex Form-A-Gasket Red High Temperature Silicone Adhesive Sealant or equivalent.
5. Use Combustion Research Corp. P/N 1810.VT.400 (Metalbestos 4RV-RT) or P/N 1811.VT.400 (Simpson Dura Vent 4GVVTH) vent caps.

HORIZONTAL VENTING

1. For single burner horizontal venting use:
 Combustion Research Corporation P/N 1811.VT.400 (Simpson Dura Vent 4GVVTH).
2. A 4 inch O.D. flue pipe (single wall galvanized, aluminized or stainless steel) is recommended. Maximum flue length may be twenty feet (20'). Do not use more than two (2) 90° elbows. Insulate as required to prevent condensation.
3. Use "B" vent for any combustible wall penetration.
4. For multiple unit venting use:
 Combustion Research Corporation PN 1811.VT.600 (Simpson Dura Vent 6GVVTH) for side wall or roof penetrations.
 A 6 inch O.D. flue pipe (single wall galvanized, aluminized or stainless steel) is recommended. Maximum flue length may be twenty feet (20'). Do not use more than two (2) 90° elbows. Insulate as required to prevent condensation.
5. Any portion of the flue pipe that passes through combustible material of the building must use "B" vent and have a minimum 1" clearance and use an approved thimble (refer to ANSI Z223.1 current standard).
NOTE: Use ONLY the PN 1811.VT.400 or 1811.VT.600 for horizontal side wall applications. The vent cap shall extend at least 18" from the wall.
6. All Joints in the flue should be sealed. Use General Electric RTV 106 or Permatex Form-A-Gasket Red High Temperature Silicone Adhesive Sealant or equivalent.
7. Make sure that horizontal vents will not be obstructed by snow build up. It is recommended that a minimum two-foot clearance be maintained around the vent.
8. Because exhaust gases may cause degradation of building materials, the horizontal vent cap must be installed a distance from the exterior wall surface of at least 6 inches - See page 21.
9. The vent piping shall rise not less than 1/4" per foot from the start of the vent system to the vent terminal.

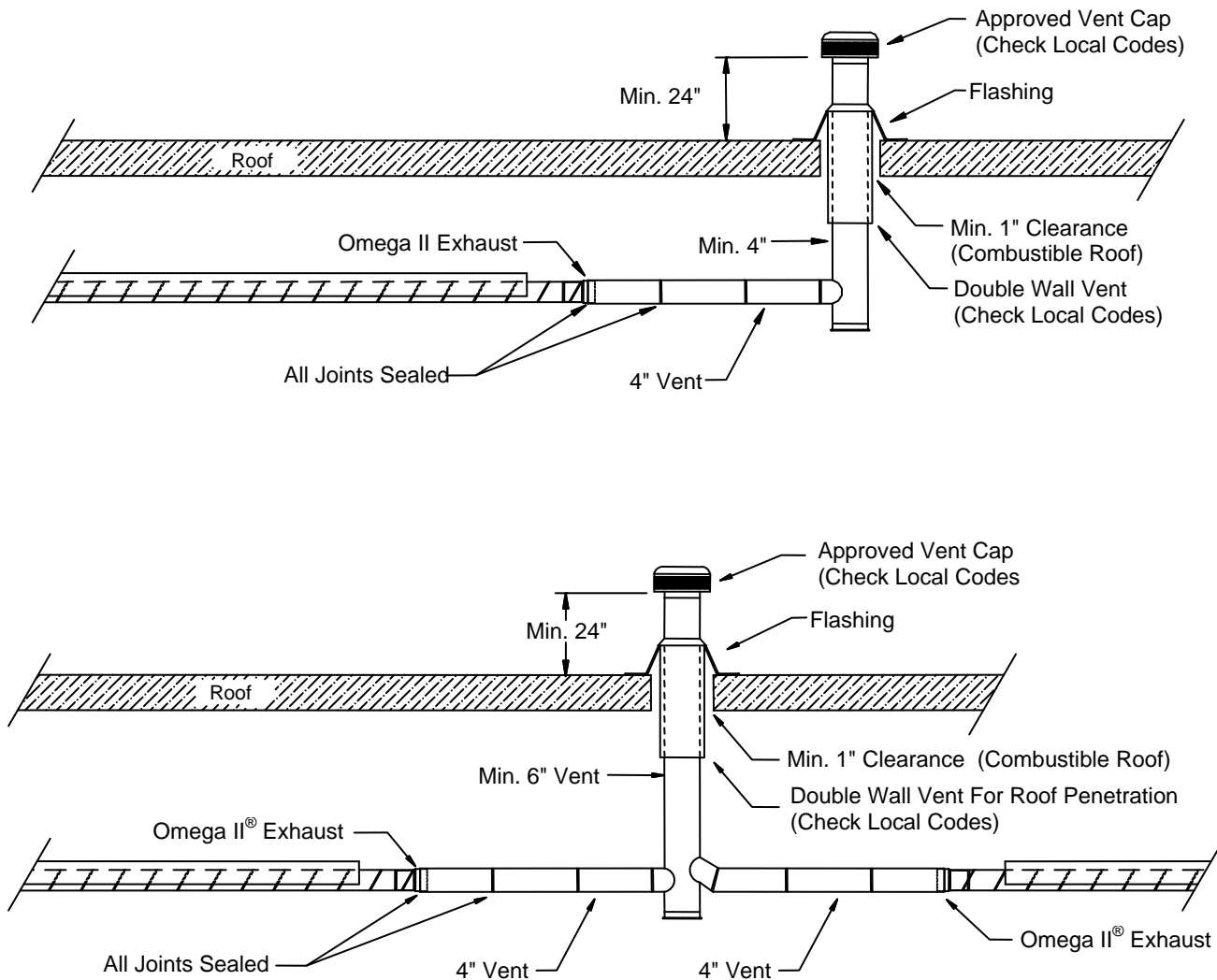

COMMON VENTING

1. The total stack length from the *OMEGA II*® exhaust to the point where it terminates should be a minimum of three feet (3') and a maximum of twenty feet (20'). The portion of flue pipe that passes through the roof (or attic space) be a double wall vent - 'B' vent (check local codes).
2. Horizontal runs to vertical vent should never exceed 75% of the vertical height of the vent stack. Open area of common exhaust must equal the sum of the open area of individual flue vents connected to it. Refer to the ANSI Z223.1 (current standard) (same as bulletin NFPA-54) for listing of various vent sizing for power vented appliances. The minimum vent height and diameter must comply with the above standard.
3. When exhausting more than one *OMEGA II*® heater into a common stack the same thermostat must control all associated heaters.
4. Connections to a common stack should be staggered so as to avoid direct opposition between streams of combustion gasses.
5. A 1" minimum clearance must be maintained around vent when passing through a combustible roof.
6. An approved Vent Cap should be used on all through the roof applications. The National Fire Protection Standards, NFPA Numbers 54 and 211, require that unless an approved Vent Cap is used the vent must extend at least two feet above the highest portion of a building within ten feet.

All Joints in the flue should be sealed. Use General Electric RTV 106 or Permatex Form-A-Gasket Red High Temperature Silicone Adhesive Sealant.

HORIZONTAL VENTING, NON-COMBUSTIBLE WALLS

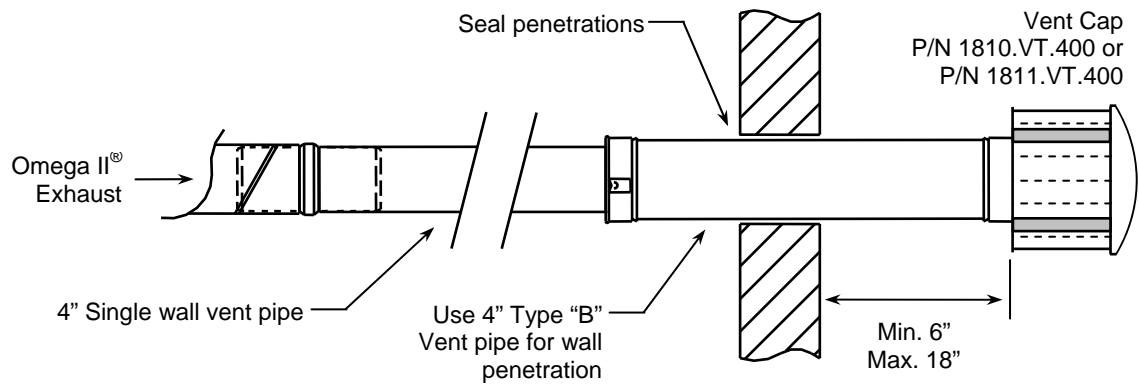

HORIZONTAL VENTING, COMBUSTIBLE WALLS

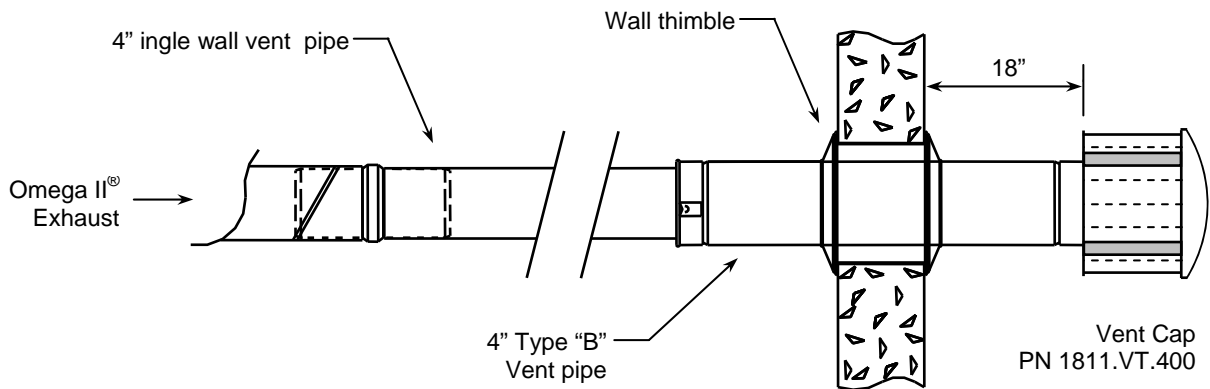

UNVENTED OPERATION

Although the *OMEGA II*® units are approved for un-vented operation, THIS IS NOT A RECOMMENDED OPTION. The reason being that when the products of combustion are discharged into the heating space, ventilation of this heating space is required. For proper ventilation, code requires that a positive air displacement of 4 CFM per 1000 BTU/Hr input of gas input be provided for insulated buildings. We recommend that 8 CFM per 1000 BTU/Hr input be used for un-insulated buildings. This air

displacement should be done mechanically and interlocked with the burners. This will insure that both the heaters and the ventilation operate simultaneously.

DO NOT USE UNVENTED SYSTEMS IN AGRICULTURAL APPLICATIONS.

NOTE:

Install exhaust vent on motor side of burner assembly. Installation on combustion air inlet side can result in burner pulsation and back firing.

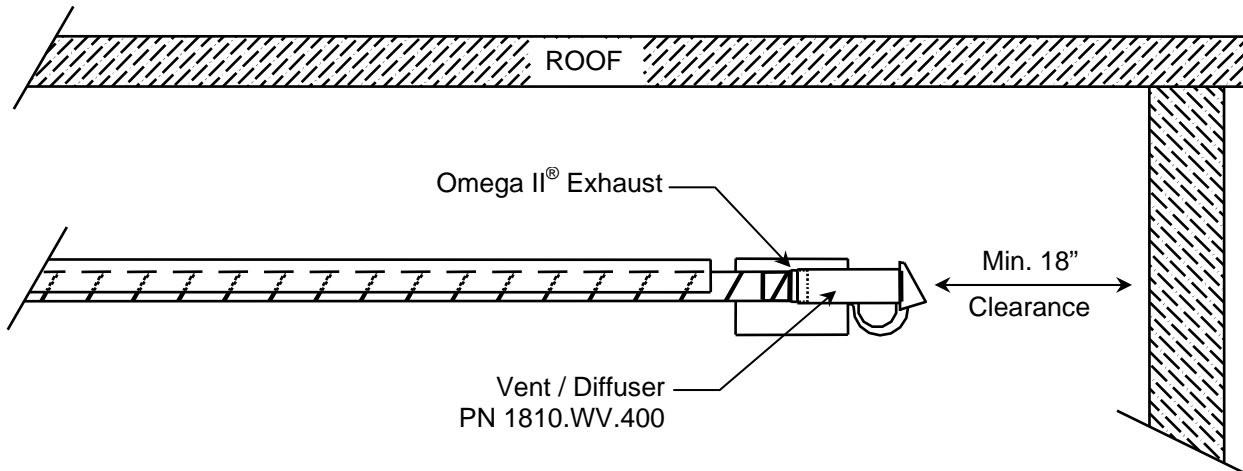

A "U" tube system is shown above. The vent terminal **MUST** be installed on the motor side of the burner assembly. **DO NOT** install the vent terminal on the combustion air inlet side. Installation on combustion air inlet side can result in burner pulsation and back firing.

NOTE: DO NOT USE UN-VENTED SYSTEMS IN AGRICULTURAL APPLICATIONS

GENERAL

The requirements and practices described below are based on the National Electrical Code ANSI/NFPA No. 70 (current standard) and the Canadian Electric Code. Although the requirements are uniform throughout the country, local electrical codes may deviate from the National Electrical Code and the Canadian Electric Code, therefore, local inspection authorities should be consulted regarding local requirements.

⚠ WARNING

ELECTRICAL SHOCK



DANGER OF SEVERE INJURY OR DEATH

Field wiring to the heater and vacuum exhauster must be connected and grounded in accordance with national, state, provincial, local codes and to the guidelines outlined in this manual. In the United States refer to the most current revisions to the ANSI/NFPA 70 Standard and in Canada refer to the most current revisions to the CSA C22.1 Part I Standard.

BURNER ASSEMBLY

Safety control circuits must be a two wire circuit with a separate earth ground, and have a nominal voltage not exceeding 125 volts. A safety control or protection device must be connected so as to interrupt the ungrounded conductor. Install a service disconnect within 3' of the **OMEGA II® Burner Assembly**.

The **OMEGA II® Burner Assembly** shall be connected to a power supply branch circuit fused at not more than the value appropriate for the rating of any control or device included in the circuit.

Each **OMEGA II® Burner Assembly** electrical requirement is 1.8 FLA amps at 115V, 60 Hz. The thermostat shall be installed on the hot (L1) side with a sufficiently fused electrical supply line. **DO NOT RUN THE ELECTRICAL SUPPLY LINES DIRECTLY ABOVE THE REFLECTOR OR BELOW THE REFLECTOR - CLEARANCE TO COMBUSTIBLES MUST BE MAINTAINED.**

NOTE: If any of the original wire as supplied with the appliance must be replaced, it must be replaced with wiring material having a temperature rating of at least 90°C.

Field wiring having a minimum rating of at least 90°C shall be used and supply circuit wiring shall have a minimum size of 14AWG.

Large enough wire must be used in connecting to the **OMEGA II® Burner Assembly**. This is necessary for two reasons: 1) carrying capacity and 2) voltage drop. The wire size necessary to provide carrying capacity without over heating is determined by electrical codes which specify a minimum wire size for the amperage used. Most

electrical supply problems are caused by voltage drop due to long runs, or low voltage supplied by the utility.

The correct size wire should be carefully selected before the installation is made. The first step is to establish what voltage will be supplied by the utility. This will vary across the country and should be verified by the utility and by actual measurement of the supply voltage prior to installation. The following chart shows maximum wire lengths which will keep the voltage drop to a minimum of 10% at various currents at 115V. Only copper wiring should be used.

WIRE LENGTH FOR 10% VOLTAGE DROP IN FEET - 115V 60HZ

AMPERES	COPPER WIRE SIZE			
	No.14	No.12	No.10	No. 8
15	150	225	350	600
20	110	175	275	450
25	90	140	225	350
30	75	125	150	300
35	-	100	135	250
40	-	85	125	225
45	-	-	110	200
50	-	-	-	175

When supplying single phase from a three phase system, use a suitably sized machine tool transformer to transform 460V or 230V three phase to 115V single phase. Under no circumstances use 277V single phase input.

WARNING: Do not use 277 volt.

INTERNAL WIRING DIAGRAMS

FENWALL – TRITON SERIES CONTROL

POINT TO POINT DIAGRAM

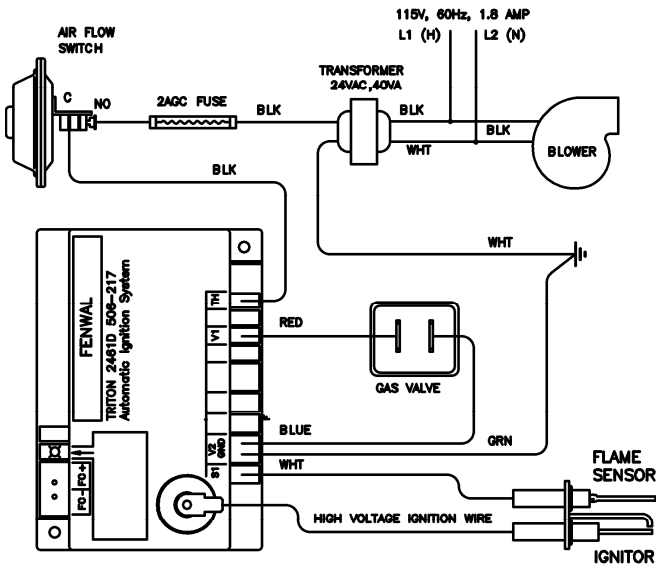

LADDER DIAGRAM

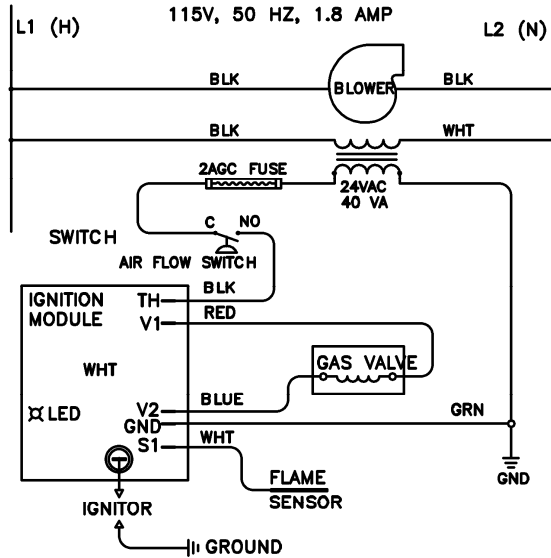

ROBERTSHAW DS 845 SERIES IGNITION CONTROL

POINT TO POINT SCHEMATIC

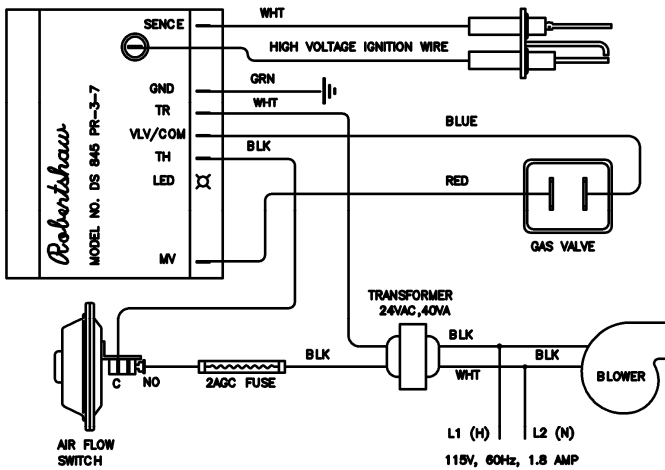

LADDER DIAGRAM

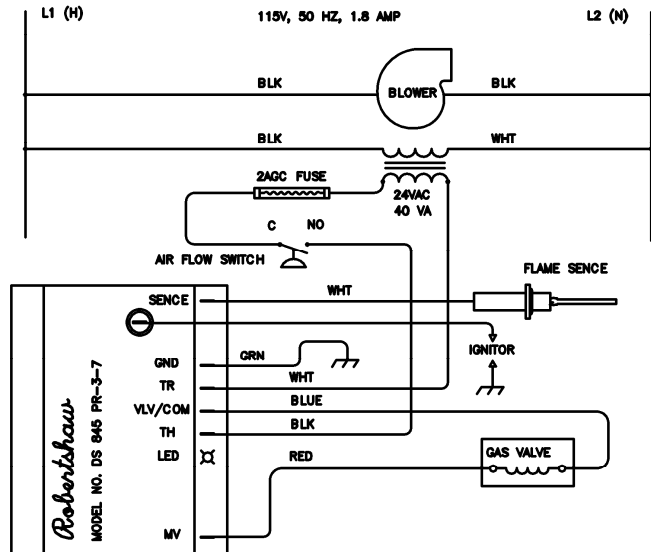

!! WARNING !!

**DO NOT ATTEMPT TO RE-WIRE INTERNAL BURNER WIRING
24 VOLT TRANSFORMER IS NOT TO BE USED FOR ANY THERMOSTAT OPERATION**

LINE VOLTAGE THERMOSTAT WIRING

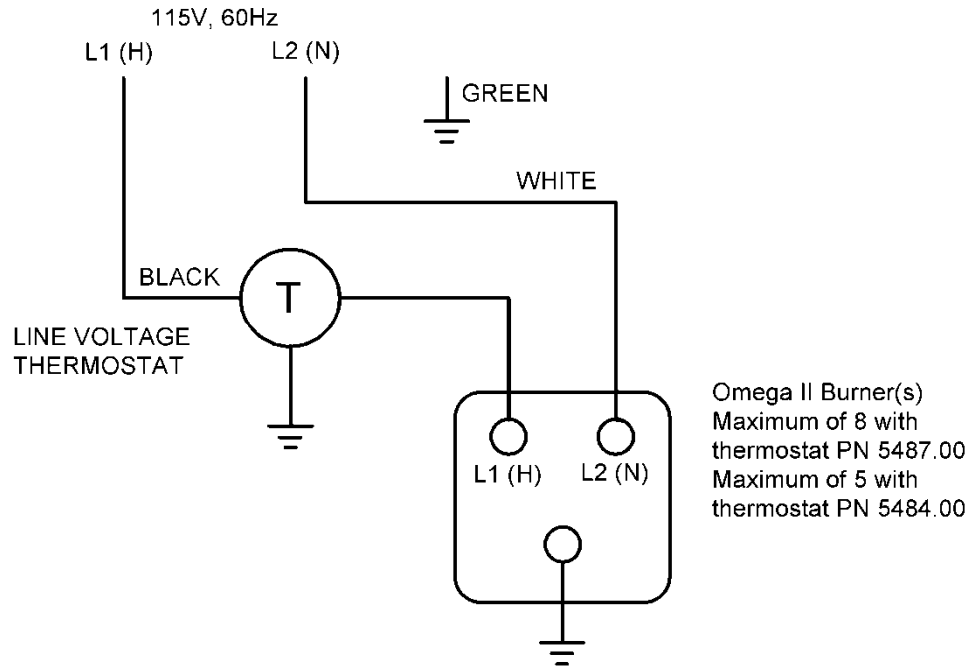

LOW VOLTAGE THERMOSTAT WIRING

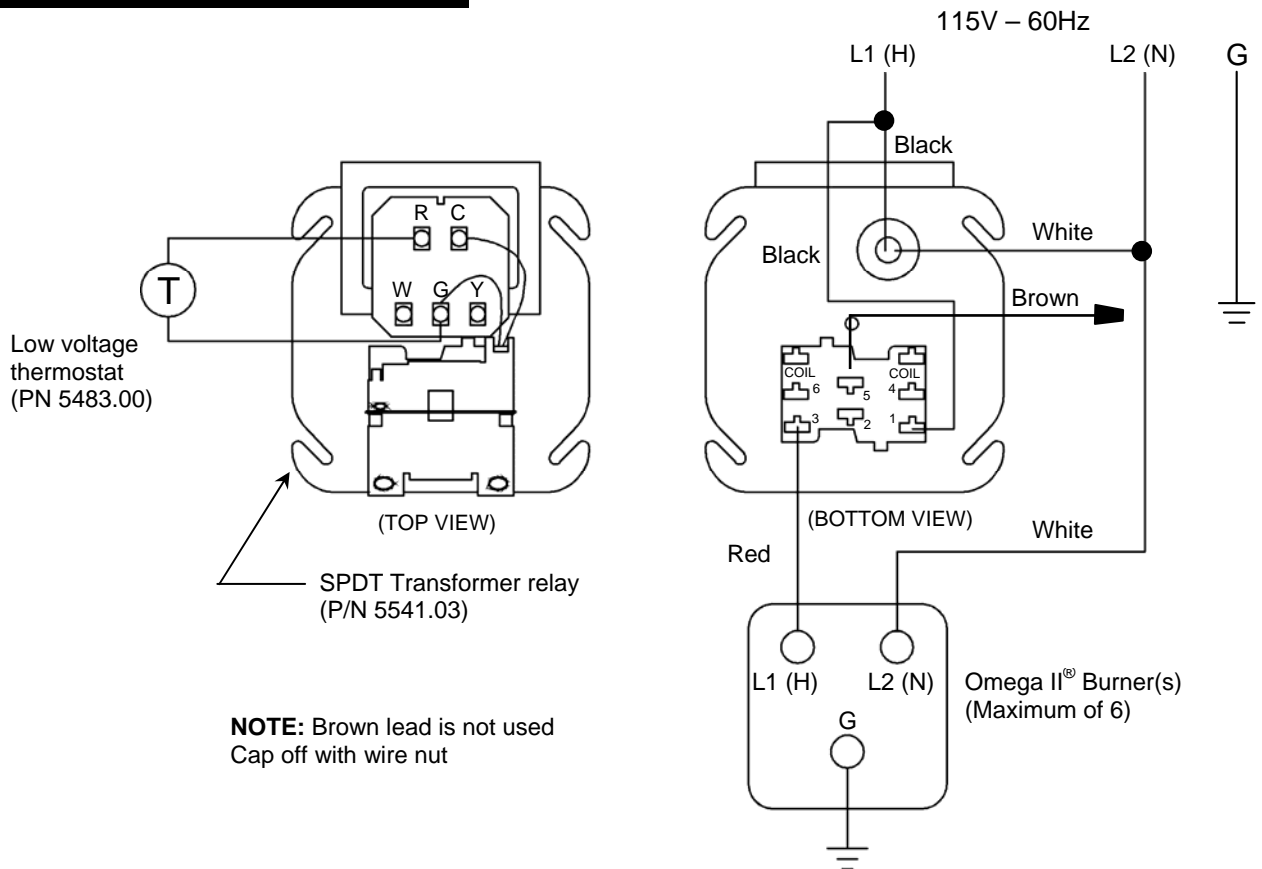

GENERAL SAFETY INFORMATION

Follow all local electrical and safety codes, as well as the National Electrical code (NEC) and the Occupational Safety and Health Act (OSHA).

1. *OMEGA II® BURNER ASSEMBLY* must be securely and adequately grounded. This can be accomplished by wiring with a grounded, metal-clad raceway system, by using a separate ground wire connected to the bare metal of the blower frame, or other suitable means.
2. Always disconnect power source before working on or near a motor to its connected load. If the power disconnect point is out of sight, lock it in the open position and tag to prevent unexpected application of power.
3. Be careful when touching the exterior of an operating motor -- it may be hot enough to be painful or cause injury. With modern motors, this condition is normal when operating at rated load and voltages -- modern motors are built to operate at higher temperatures.
4. Protect the power cable from coming in contact with sharp objects.
5. Do not kink the power cable and never allow the cable to come in contact with oil, grease, hot surfaces, or chemicals.
6. Make certain that the power source conforms to the requirements of your equipment.
7. When cleaning electrical or electronic equipment, always use an approved cleaning agent such as dry cleaning solvent.
8. This is not an explosion proof blower. Do not use where explosive fumes or gases are present.

OPERATION

Before connecting the system to the electric supply, check the electrical characteristics as indicated on the Rating/Nameplate to insure proper voltage.

With the air system in full operation and all ducts attached, measure current input to the motor and compare with the nameplate rating to determine if the motor is operating at safe load conditions and not overloaded.

RADIANT TUBING CHECK

1. Inspect entire network of radiant tubing to insure that all fittings are securely screwed together.
2. Inspect entire network of radiant tubing to insure that system is straight and assembled in a good workmanship manner.

PRECONDITIONS TO BE CHECKED BEFORE BURNER SYSTEM STARTUP

1. System has been installed to Combustion Research Corporation recommendations in Installation Manual and nameplate data.
2. the system must be installed with adequate clearance to combustibles as outlined in this manual. In storage areas where stacking of materials may occur, the

installer must provide signs which specify the maximum stacking height so as to maintain the required clearance to combustibles.

3. Electrical input to building. It must provide a minimum service requirement for each heating zone as follows: 15 amp service, 115V AC/60 Hz (1-ph.). Check total system amperage requirements for proper service requirements
4. NATURAL GAS SERVICE
 - a. Meter and pipe work to be adequate size for total building requirements
 - b. 1030 Btu/ft³ at minimum of six inches (6") or seven inches (7"), as outlined in the technical data section of this manual, W.C. at input side of burner regulator during full operational load. (Manifold pressure is 3.5" W.C.).
5. Propane Service
 - a. Storage tanks should be large enough to vaporize required maximum load of the installed heating equipment.
 - b. Vaporizer system and high pressure regulators system installed as required and set at 13.5 W.C. outlet.
 - c. 2500 Btu/ft³ at minimum of 11.0" at input side of regulator on burner during operation. (Manifold pressure is 10.0" W.C.)
6. All gas valves in meter house and service cocks open. All feed lines have been purged of air.
7. When high pressure gas supplies are used, make sure the proper regulators, manual valves and flexes have been installed properly.
8. Combustion air and exhaust connections have been installed and are secure.

TO START SYSTEM

WARNING

FIRE OR EXPLOSION HAZARD



FIRE OR EXPLOSION HAZARD. CAN CAUSE DEATH, SEVERE INJURY AND/OR PROPERTY DAMAGE.

It is the installer's final responsibility to verify correct gas usage.

Do not use a gas control set for natural gas on LP as or a gas control set for LP Gas on Natural Gas.

1. Check to insure that main gas cock from meter is open. Check burner to insure that gas cock is open.
2. Turn the main power switch ON and check fuse.
3. Set the thermostat higher than the existing temperature of the area to be heated. The following step should take place automatically:

The blower is powered and will start. The air flow switch is then powered and supplies power to the burner control. The ignition control will produce the spark ignition as well as opening the gas valve and allowing gas flow. The gas will then ignite.

4. Check burner to see that it is operating.
5. At this time, manually shut off the gas and verify that the "flame failure shutdown" occurs. Open the manual gas valve and turn off the power to the **OMEGA II® BURNER ASSEMBLY** to reset the control.
6. Set the thermostat down to the desired temperature.

NOTE - When the heater is initially fired, solvents or any oil that is on the pipe work and fittings will burn off and form a light haze in the building which can best be removed by the ventilation system in the building, or by opening the doors. This is a one time problem and will not recur.

SEQUENCE OF OPERATION

1. Thermostat calls for heat.
2. Combustion air blower is energized.
3. The differential air flow switch proves operation of the blower and the ignition control is energized.
4. After pre-purge timing, the spark ignition and gas valve are energized.
5. The ignition control senses the flame (flame rectification) and turns off the spark ignition.
6. After the thermostat is satisfied, the power is removed from the burner assembly causing the ignition control and gas valve to turn off and the blower shuts down.
7. System waits for the next call for heat.

RESETTING THE IGNITION CONTROL

The **OMEGA II® BURNER ASSEMBLY** is equipped with an automatic lockout control which is activated after 60 seconds if a burner should fail to ignite. If your burner should lock out, it should be reset by the following method:

1. Turn off the disconnect switch located near the burner or turn down the thermostat to stop the entire system.
2. Wait 5 minutes for the ignition timer switch to cool and automatically reset.
3. Turn the power back on and/or turn the thermostat back up.
4. The system will now automatically recycle on the thermostat to maintain desired room temperature.

IF THE BURNER WILL NOT LIGHT AFTER TWO RESET TRIALS, CONTACT YOUR INSTALLER FOR SERVICE.

GAS CONTROL KNOB SETTING:

The gas control knob has two settings.

OFF (knob turned ↻ clockwise) prevents main burner gas flow.

ON (knob turned ↺ counter clockwise) permits main burner gas flow. Under control of the thermostat and direct ignition module, gas can flow to the main burner.

NOTE: Controls are shipped with the gas control knob in the ON position.

WARNING

FIRE OR EXPLOSION HAZARD



FIRE OR EXPLOSION HAZARD. CAN CAUSE DEATH, SEVERE INJURY AND/OR PROPERTY DAMAGE.

1. Do not force the gas control knob. Use only your hand to turn the gas control knob. Never use tools.
2. If the gas control knob will not operate by hand, a qualified service technician should replace the gas control.

STOPPING THE SYSTEM FOR SERVICE

1. For servicing an individual **OMEGA II® BURNER ASSEMBLY**, turn off the disconnect switch which should be mounted within two feet (2') of the unit. Close the gas supply to the burner at the individual burner gas cock.
2. To service the thermostat, turn off the electrical power at the main power disconnect box.
3. Before servicing any gas component, shut off the gas supply at the meter by closing the main gas valve.

CHECK SAFETY SHUTDOWN PERFORMANCE

NOTE: Read steps 1-7 below before starting safety shutdown or safety lockout tests for the direct ignition (DI) module.

1. Turn gas supply off.
2. Set the thermostat or controller above room temperature to call for heat.
3. Watch for ignition spark immediately or following prepurge. See ignition module specifications.
4. Time length of ignition operation. See DI module specifications.
5. After the module locks out, open gas control and ensure there is no gas flow to main burner.
6. Set the thermostat below room temperature and wait one minute.
7. Operate system through one complete cycle to ensure all controls operate properly.

⚠ WARNING

ELECTRICAL SHOCK



DANGER OF SEVERE INJURY OR DEATH

ALWAYS DISCONNECT POWER SUPPLY BEFORE SERVICING THE BLOWER OR WORKING WITH THE UNIT FOR ANY REASON. THIS IS ESPECIALLY IMPORTANT WITH UNITS EQUIPPED WITH AUTOMATIC THERMAL RESET PROTECTION. UNIT MAY ACTIVATE WITHOUT WARNING!

GENERAL AND YEARLY MAINTENANCE

At regular intervals or at least once a year the entire system should be inspected.

OMEGA II® BURNER ASSEMBLY:

The gas connecting flex should be inspected for any cracks or breaks. Use a soap solution on the gas flex and gas piping to verify any leaks. **DO NOT USE OPEN FLAME FOR LEAK TEST.**

Check combustion air inlets and connecting duct work for obstructions and breakage; repair as needed.

Inspect hanging hardware, such as chains, for wear. If any wear is present, the system must not be operated until the chain(s) or associated hardware has been replaced.

Look for any deterioration in the housing assembly. Replace or repair.

Radiant Tubing:

⚠ WARNING

FIRE OR EXPLOSION HAZARD



FIRE OR EXPLOSION HAZARD. CAN CAUSE DEATH, SEVERE INJURY AND/OR PROPERTY DAMAGE.

Damaged or nonconforming radiant tubing must be replaced with appropriate product as manufactured by Combustion Research Corporation.

The radiant tubing should be inspected at the beginning of every heating season. Look for cracks, holes, physical damage, etc. Replace as needed.

NOTE:

Use only approved **OMEGA II®** tube which is specifically manufactured for the **OMEGA II®** system. Use of substitute materials can result in an unsafe condition and will void any and all warranties.

DIAGNOSIS AND TESTING OMEGA II® BURNER ASSEMBLY:

IF THE BURNER DOES NOT OPERATE, A "SYSTEM CHECK" MUST BE MADE AS FOLLOWS:

SYSTEM CHECK

⚠ WARNING

FIRE OR EXPLOSION HAZARD



FIRE OR EXPLOSION HAZARD. CAN CAUSE DEATH, SEVERE INJURY AND/OR PROPERTY DAMAGE.

Perform the safety shutdown test any time work is done on a gas system.

1. Check for proper installation of unit (refer to owner's manual). If power is not present, check power supply to input terminals with AC voltmeter and check fuse in burner box.
2. Remove tube fitting from air switch and insert new fitting with short rubber hose attached. Normally open air flow switch can be operated with mouth vacuum to check performance. If air flow switch does not close, replace air flow switch.
3. Provided air flow switch is operating, listen for high voltage arc, an audible spark "ticking." **(DO NOT TOUCH IGNITION OUTPUT LEADS OR IGNITION**

ELECTRODES.) Check to see if high voltage leaks occur at porcelains and high voltage leads.

4. If ignition arc is not present or sporadic, turn off power and check gap. It should be approximately .10 inch. **(DO NOT TRY TO MEASURE HIGH VOLTAGE OUTPUT.)** High voltage wire should not touch casing as grounding can occur when wires are wet.
5. If ignition wires and electrodes are set as above, and power is shown but no ignition arc is present, the ignition assembly is defective and the electronics should be replaced.
6. Remove gas jet, inspect for possible obstruction or incorrect orifice size.
7. Disconnect power and check terminals to be sure that there are no loose spade connections or broken wires.

ELECTRONIC PROVEN SPARK IGNITION CONTROL WITH 100% LOCKOUT

APPLICATION

The solid state ignition control will ignite the gas by spark. The gas is ignited and burns during each running cycle.

Should a loss of flame occur, the main valve closes and a retry for ignition will commence. This control has an internal 100% lockout function to completely shut down the system should the gas fail to ignite within 30 seconds. To initiate a re-ignition trial when lockout occurs, the power must be interrupted for 5 minutes.

The solid state ignition control must not be subjected to temperatures below -40°F (-40°C) or above 150°F (66°C).

CAUTION: When it is necessary to replace a main gas valve used with this control, the replacement valve must have the same valve closing time as that approved on the original equipment by the recognized testing agency.

GAS SUPPLY FAILURE ON START

1. Thermostat calls for heat.
2. Air flow is proven.
3. Valve and spark are energized after pre-purge.
4. After a 30 second trial for ignition, the system will lockout to completely disarm the system.
5. In order to initiate a re-ignition trial, the power must be interrupted for 5 minutes.

POWER INTERRUPTION ON START

1. No gas will flow during power interruption.
2. Normal sequence will resume when power is restored.

POWER INTERRUPTION DURING RUNNING CYCLE:

1. Valve is de-energized.
2. Valve and spark are energized when power is restored and normal sequence will resume.

TURNING OFF THE APPLIANCE

VACATION SHUTDOWN -- Set the thermostat to the desired room temperature while you are away.

COMPLETE SHUTDOWN -- Push the gas control knob in slightly and turn clockwise ↷ to OFF. Do not force. Appliance will completely shut off. Follow the Lighting Procedures above to resume normal operation.

IF MAIN BURNER WILL NOT COME ON WITH CALL FOR HEAT:

1. Ensure gas control knob is in the ON position (rotate counter clockwise ↶).
2. Adjust thermostat several degrees above room temperature.
3. Using AC voltmeter, measure voltage across MV terminals at gas control.
4. If no voltage is present, check control circuit for proper operation.
5. If proper control system voltage is present, replace gas control.

STOP: READ ALL WARNINGS

The flame is lit automatically. If the appliance does not turn on when the thermostat is set several degrees above room temperature, follow these instructions:

1. Set the thermostat to its lowest setting to reset the safety control.
2. Disconnect all electric power to the appliance.
3. Remove the control access panel.
4. Turn gas control knob clockwise ↷ to the OFF position, DO NOT FORCE.
5. Wait 5 minutes to clear out any unburned gas. If you then smell gas, STOP! Follow Step 3 in the following Warning statement. If you do not smell gas, continue with the next step.
6. Turn the gas control knob counter clockwise ↶ to the ON position.
7. Replace the control access panel.
8. Reconnect all electric power to the appliance.
9. Set the thermostat to the desired setting.
10. If the appliance does not turn on, turn the gas control knob counter clockwise ↶ to OFF and contact a qualified service technician for assistance.

⚠ WARNING

FIRE OR EXPLOSION HAZARD



IMPROPER INSTALLATION, ADJUSTMENT, ALTERATION, SERVICE OR MAINTENANCE CAN CAUSE DEATH, SEVERE INJURY AND/OR PROPERTY DAMAGE.

1. Flame is lit automatically. Do not light the flame manually.
2. Before lighting burner flame, smell around the appliance for gas. Be sure to smell next to floor because LP gas is heavier than air.
3. IF YOU SMELL GAS:
 - ◆ Turn off the gas supply at the appliance service valve. On LP gas systems, turn off gas supply at the gas tank.
 - ◆ Do not light any appliances in the house.
 - ◆ Do not touch electrical switches or use the phone.
 - ◆ Leave the building and use a neighbor's phone to call your gas supplier.
 - ◆ If you cannot reach your gas supplier, call the fire department.
4. Do not force the gas control knob. Use only your hand to push down or turn the gas control knob. Never use any tools. If the gas control knob will not operate by hand, a qualified service technician should replace the gas control. Force or attempted repair may result in a fire or explosion.
5. The gas control must be replaced in case of any physical damage, tampering, bent terminals, missing or broken parts, stripped threads, and evidence of exposure to heat.

MAINTENANCE

Regular preventive maintenance is important in applications that place a heavy load on system controls, such as in the commercial cooking and agricultural and industrial industries because:

1. In applications where the equipment operates 100,000-200,000 cycles per year. Such heavy cycling can wear out the gas control in one to two years.
2. Exposure to water, dirt, chemicals and heat can damage the gas control and shut down the control system.

NOTICE

Do not apply a jumper across or short the valve coil terminals. Doing so may damage the ignition module.

⚠ WARNING

FIRE OR EXPLOSION HAZARD



IMPROPER INSTALLATION, ADJUSTMENT, ALTERATION, SERVICE OR MAINTENANCE CAN CAUSE DEATH, SEVERE INJURY AND/OR PROPERTY DAMAGE.

Do not disassemble the gas control. The gas control contains no replaceable components. Attempted disassembly or repair may damage the gas control.

The maintenance program should include regular checkout of the gas control. Maintenance frequency must be determined individually for each application. Some considerations are:

1. **Cycling frequency.** Appliances that may cycle 100,000 times annually should be checked monthly.
2. **Intermittent use.** Appliances that are used seasonally should be checked before shutdown and again before the next use.
3. **Consequence of unexpected shutdown.** Where the cost of an unexpected shutdown would be high, the system should be checked more often.
4. **Dusty, wet or corrosive environment.** Since these environments can cause the gas control to deteriorate more rapidly, the system should be checked more often.

The gas control should be replaced if:

1. It does not perform properly on checkout or troubleshooting.
2. The gas control knob is hard to turn or push down, or it fails to pop back up when released.
3. The gas control is likely to have operated for more than 200,000 cycles.

CHECKOUT PROCEDURE

Before leaving installation, several complete operating cycles should be observed to see that all components are functioning properly.

1. Before turning on the main electrical power switch, be sure all gas supply lines are purged of air.
2. Close main manual shutoff valve and wait for 5 minutes, then turn "A" valve to counter clockwise ↶ to "ON" position.
CAUTION: Check for positive gas seal using soap solution on valve inlet and all upstream pipe connections.
3. Turn on main electrical power switch and close thermostat contacts.
4. After the control is powered it will automatically energize the spark and the gas valve.

5. The sensing probe detects the presence of the low fire flame and the control de-energizes the spark and the valve will remain open. Check valve outlet and other downstream pipe connections with a soap solution.
6. Turn the thermostat to a low dial setting to open contacts. The main gas flame should be extinguished.
7. For 100% shutoff check, set thermostat to low dial setting (system off). Disconnect sensing probe lead at control terminal.
8. Turn thermostat to a high dial setting to energize spark ignition and valve. The gas should ignite. After 30 seconds, the system should "lockout" and burner functions are off (no gas flow, no spark). If the system does not go into "lockout," follow the installation instructions to replace the control. Repeat the 100% shutoff check. Note blower will not shut down when ignition "lockout" occurs.
9. Set thermostat again to a low dial setting (system off), connect probe lead to control terminal. Set thermostat to normal setting to put system back in service.

CHECK SAFETY SHUTDOWN PERFORMANCE

! WARNING

FIRE OR EXPLOSION HAZARD



IMPROPER INSTALLATION, ADJUSTMENT, ALTERATION, SERVICE OR MAINTENANCE CAN CAUSE DEATH, SEVERE INJURY AND/OR PROPERTY DAMAGE.

Perform the safety shutdown test anytime work is done on a gas system.

NOTE: Read steps 1-7 below before starting safety shutdown or safety lockout tests for the ignition module.

1. Turn gas supply off.
2. Set the thermostat or controller above room temperature to call for heat.
3. Watch for ignition spark immediately or following pre-purge. See ignition module specifications.
4. Time length of ignition operation. See ignition module specifications.
5. After the module locks out, open gas control and ensure there is no gas flow to main burner.
6. Set the thermostat below room temperature and wait one minute.
7. Operate system through one complete cycle to ensure all controls operate properly.

IGNITION CHECKOUT PROCEDURES

A combination voltmeter and micro-ammeter with a DC micro-ammeter range setting of 0 to 10 micro-ampere is required. Follow meter instructions for proper use. TO CHECK AC VOLTAGES:

1. Set range selection switch to 150V AC before connecting leads.
2. Connect wire leads in parallel with voltage to be measured.
3. Read voltage on AC scale.

TO CHECK CURRENT FROM FLAME SENSING PROBE:

1. Set range selector switch to 10 micro-amperes before connecting leads.
2. Turn off power supply to ignition control.
3. Disconnect sensing probe cable from sensor terminal or ignition control.
4. Connect red (positive) meter lead to sensor terminal.
5. Connect black (negative) meter lead to probe cable.
6. Turn on electrical supply to system and cycle system through the thermostat.
7. After system has ignited, the meter should read 0.7 micro-amperes or higher. If less than 0.7 micro-amperes, the control may need to be replaced. Check all wiring connections before replacing control.
8. Turn off supply voltage.
9. Disconnect meter from sensor terminal and probe cable.
10. Reconnect probe cable to sensor terminal.
11. Turn on supply voltage.

IGNITOR / FLAME SENSOR

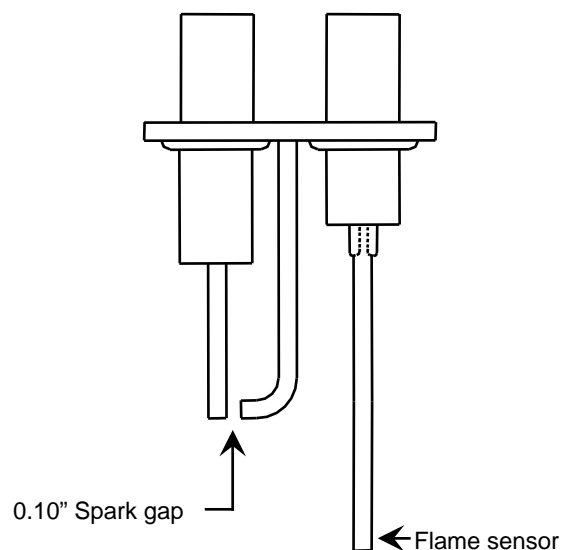

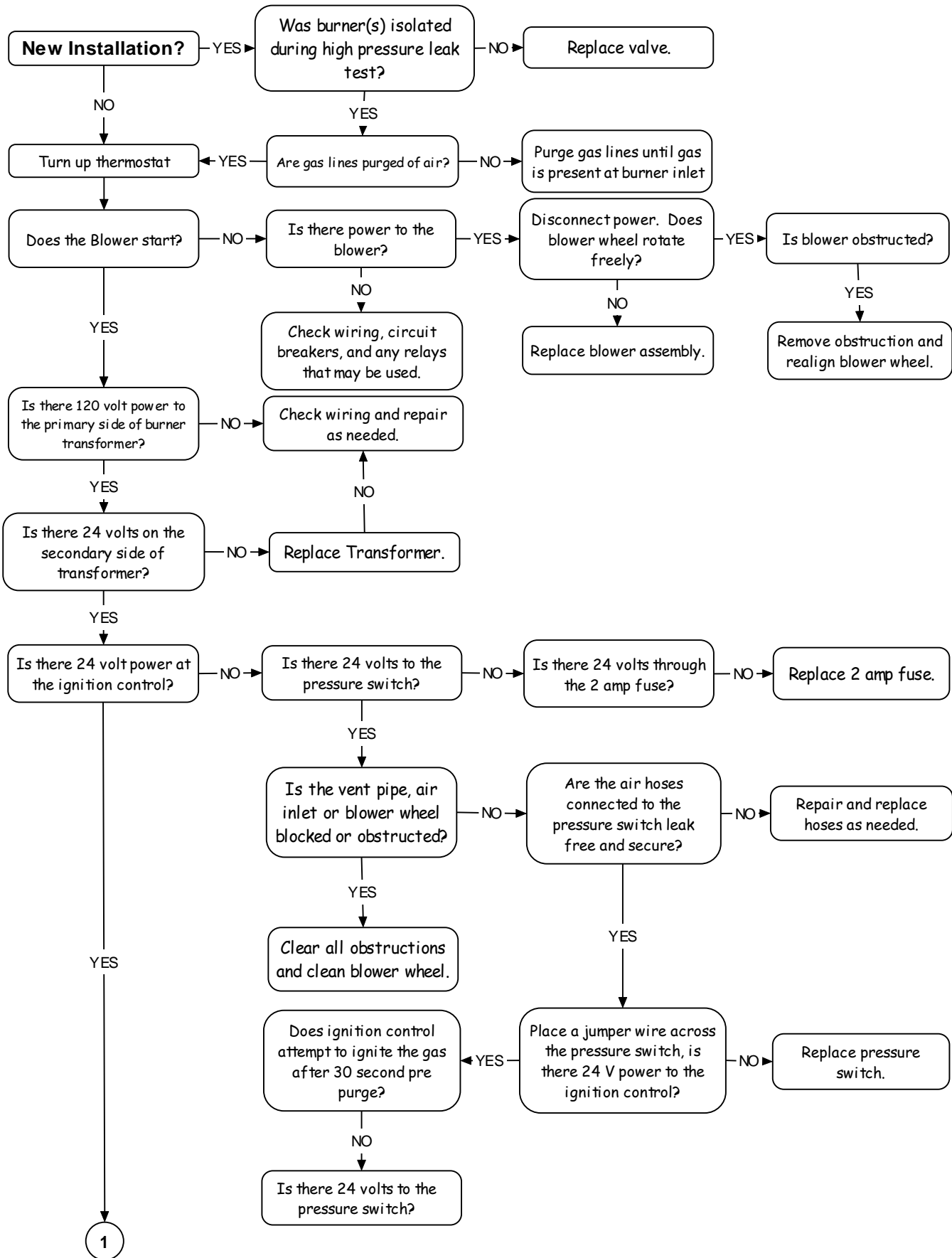

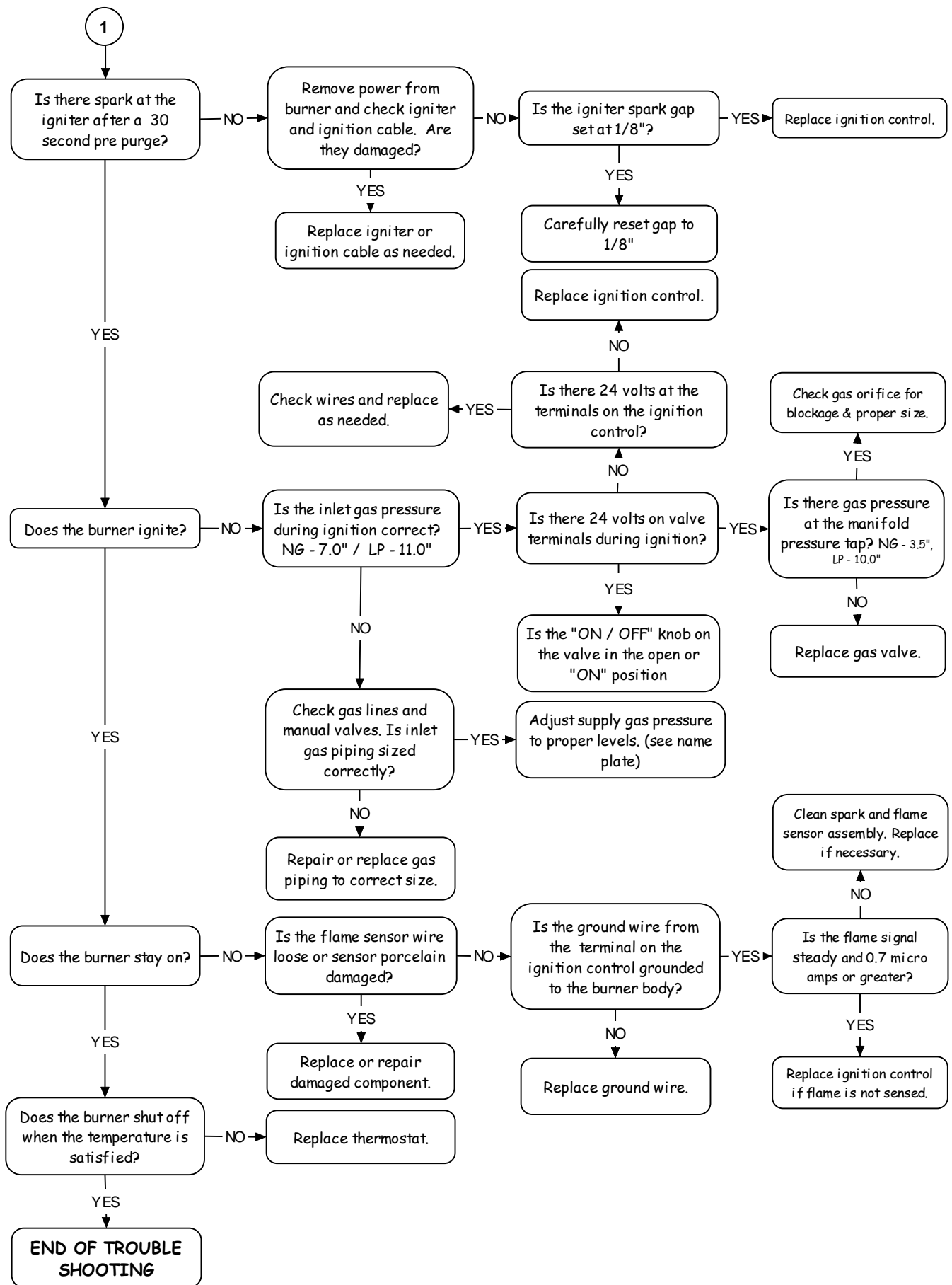

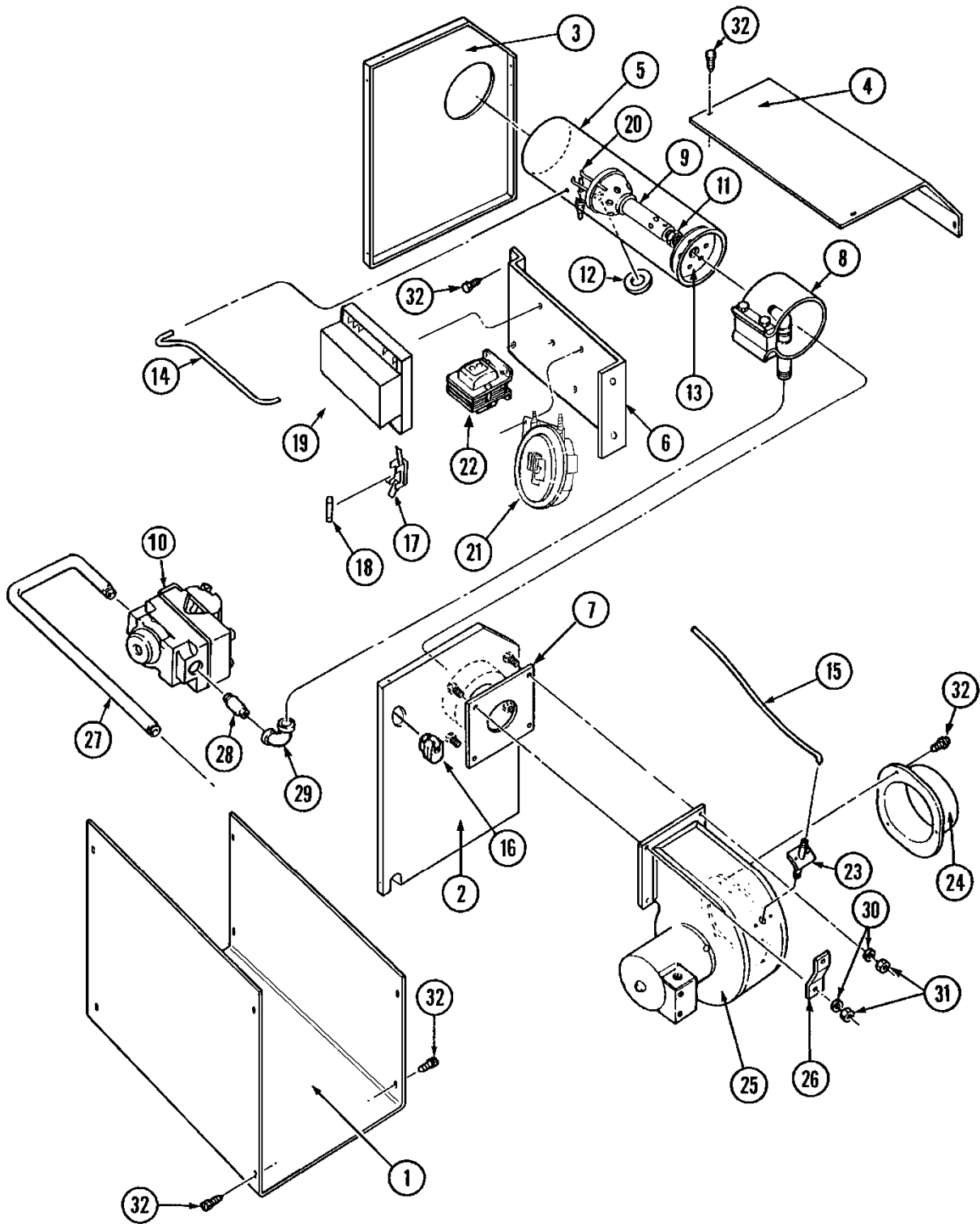



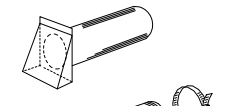
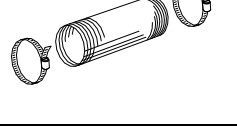
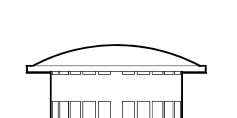
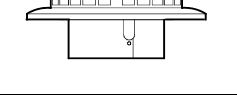
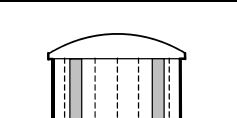
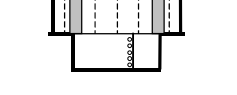
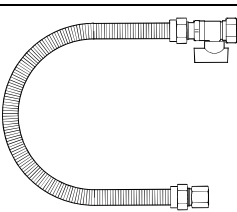
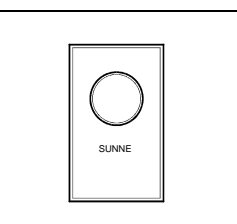
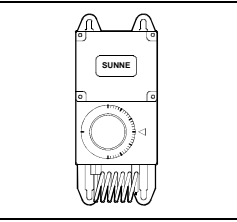
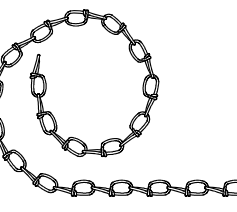
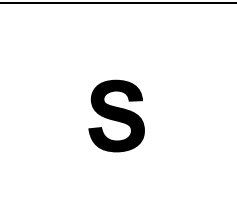

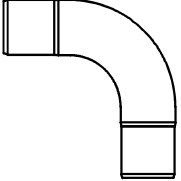
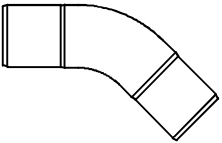
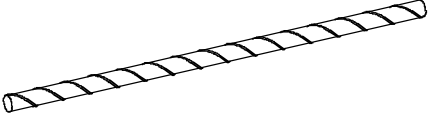
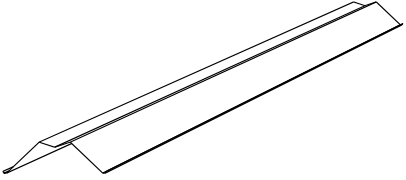
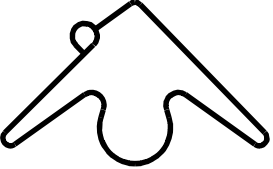

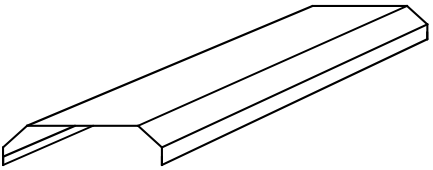
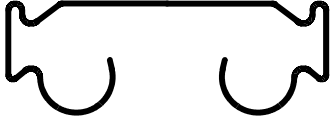
Ref. No.	Part No.	Description	Qty.
1	910.06A	Bottom Cover	1
-2	910.04AW	Back Plate - For 3.5" System	1
-2	910.04BW	Back Plate - For 4.0" System	1
3	910.03	Front Plate	1
4	910.05	Top Cover	1
-5	910.18	Burner Tube - For 3.5" System	1
-5	910.19	Burner Tube - For 4.0" System	1
6	910.16.D	Control Mounting Bracket	1
-7	910.12.A	Orifice Plate for 0910 thru 0914 (100K thru 80K)	1
-7	910.11	Orifice Plate for 0915 thru 0919 (75K thru 55K)	1
-7	910.12	Orifice Plate for 0920 through 0922) (50K thru 40K)	1
-8	910.40	Drawband Coupler / Gas Manifold for 3.5" Systems	1
-8	910.40.1	Drawband Coupler / Gas Manifold for 4.0" Systems	1
-9	925.01	Mixing Nozzle - For all systems except for 0941 thru 0945 systems	1
-9	926.00	Mixing Nozzle - For 0941 - 0945 systems	1
10	5285.XX	Gas Valve - Specify Manufacture & Manufacture Model No.	1
11	5190.NG.XXX 5190.LP.XXX	Gas Orifice - Specify Input & Gas	1
12	1300.00	Inspection Window	1
-13	910.07	Combustion Spinner (Used on 0910 - 0922 Models)	1
-13	910.07A	Combustion Spinner (Used on 0926 - 0945 Models)	1
14	1477.NY	1/4" Poly Air Flow Tube	1
15	1477.NY	1/4" Poly Air Flow Tube	1
16	1242.10	Connector - 3/8" Liquid Tight Tubing, Fitting	2
-	1242.00	Liquid Tight Tubing - 3/8" x 7.25" Long	1
17	1601.12	Fuse Block (1/4" Fuse Style)	1
18	1641.28	Fuse - 2 Amp (2AGC)	1
19	5241.XX	Ignition Module - Specify Manufacture & Manufacture Model No.	1
20	5029.10	Electrode / Sensor Assembly	1
-21	5060.07A2	Differential Pressure Switch (Used on 0910 - 0922 Models)	1
-21	5060.07A1	Differential Pressure Switch (Used on 0926 - 0935 Models)	1
-21	5060.07C	Differential Pressure Switch (Used on 0936 - 0945 Models)	1
22	5082.00	Transformer - 115 V Primary, 24VAC 40 VA Secondary	1
23	910.15	Air Flow Fitting	1
-24	910.10	4" O.D. Combustion Air Inlet (Used on 0910 - 0922 Models)	1
-24	910.10.2	4" O.D. Combustion Air Inlet (Used on 0926 - 0935 Models)	1
-24	910.10.3	4" O.D. Combustion Air Inlet (Used on 0936 - 0940 Models)	1
-24	910.10.4	4" O.D. Combustion Air Inlet (Used on 0941 - 0945 Models)	1
25	FAN.02	Blower Assembly - Less Inlet Adapter	1
26	910.13	Hanging Bracket	1
27	925.03	Inlet Gas Manifold - "J" Pipe	1
28	1183.00	1/2" NPT , Close - Black Nipple	1
29	1202.03	1/2" NPT, 90° Black Elbow	1
30	1121.01	1/4" Lock Washer	4
31	1090.00	1/4" - 20 Nut	4
32	1142.08	#8 Sheet Metal Screw	19

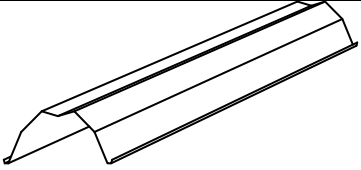
Part No.	Description	
0314.00	FRESH AIR INLET ASSEMBLY - Weather Proof Inlet 4" dia., 12" long with 24" long PVC coated Aluminum Flex with two hose clamps, 4" diameter. WT. 2.0 lbs.	
0614.00	FRESH AIR INLET ASSEMBLY - Weather Proof Inlet 6" dia., 12" long with 48" long PVC coated Aluminum Flex with two hose clamps, 6" diameter. WT. 6.0 lbs.	
1810.VT.400	ROOF OR WALL VENT - 4" diameter mushroom style round vent. For single wall or "B" Vent. Wt. 0.5 lbs.	
1810.VT.600	ROOF OR WALL VENT - 6" diameter mushroom style round vent. For single wall or "B" Vent. Wt. 0.75 lbs.	
1811.VT.400	ROOF OR WALL VENT - 4" diameter - High Wind mushroom style round vent. For "B" vent. Wt. 0.5 lbs.	
1811.VT.600	ROOF OR WALL VENT - 6" diameter - High Wind mushroom style round vent. For "B" vent. Wt. 0.75 lbs.	
0317.00 0417.00	STAINLESS STEEL GAS FLEX - 1/2" NPT (0317.01) or 3/4" NPT (0417.00) fittings and manual gas valve 36" long (Included with each burner – United States Only). Wt. 7.0 lbs.	
5484.00	THERMOSTAT - Line voltage, 9.8 FLA , 50°F to 90°F Wt. 1.0 lbs.	
5487.00	THERMOSTAT - Line voltage, Moisture proof 16 FLA, 40°F to 80°F Wt. 1.0 lbs.	
1800.CH.000	HANGING CHAIN - Double loop hanging chain, 100' - work load rating of 90 lbs. Wt. 6.5 lbs.	
1800.SH.000	"S" HOOKS - Box of 50 "S" hooks. WT. 2.0 lbs.	

Part No.	Description	
0306.AS 0406.AS	<p>90° ELBOW - ALUMINIZED STEEL - 3.5" dia. aluminized steel, 90° elbow. Wt. 3.0 lbs.</p> <p>90° ELBOW - ALUMINIZED STEEL - 4.0" dia. aluminized steel, 90° elbow. Wt. 3.0 lbs.</p>	
0336.AS 0436.AS	<p>45° ELBOW - ALUMINIZED - 3.5" dia. aluminized steel, 45° elbow. Wt. 1.5 lbs.</p> <p>45° ELBOW - ALUMINIZED - 4.0" dia. aluminized steel, 45° elbow. Wt. 1.5 lbs.</p>	
0304.AS.HT 0404.AS.HT	<p>RADIANT HEAT TUBE - ALUMINIZED/HEAT TREATED - 3.5" dia. aluminized steel heat treated radiant tube, 9'9" long. Wt. 11.25 lbs.</p> <p>RADIANT HEAT TUBE - ALUMINIZED/HEAT TREATED - 4.0" dia. aluminized steel heat treated radiant tube, 9'9" long. Wt. 12.75 lbs.</p>	
0360.00	<p>STANDARD REFLECTOR - Aluminum, 10' long. Wt. 5.0 lbs.</p>	
0361.00 0461.00	<p>COMBINATION HANGER - Heat tube & standard reflector hanger for 3.5" tube, plated 1/4" dia. wire. Wt. 0.75 LB</p> <p>COMBINATION HANGER - Heat tube & standard reflector hanger for 4.0" tube, plated 1/4" dia. wire. Wt. 0.25 LB</p>	
0362.00 0462.00	<p>REFLECTOR SUPPORT - Intermediate support for standard reflector for 3.5" tube, plated 1/4" dia. wire. Wt. 0.75 LB</p> <p>REFLECTOR SUPPORT - Intermediate support for standard reflector for 4.0" tube, plated 1/4" dia. wire. Wt. 0.25 LB</p>	
0812.00	<p>PANEL REFLECTOR - Aluminum, 10' long. Wt. 7.0 lbs.</p>	
0812.02 0412.02	<p>PANEL HANGER - Heat tube & reflector hanger for 3.5" tube, plated 1/4" dia. wire. Wt. 1.0 LB</p> <p>PANEL HANGER - Heat tube & reflector hanger for 4.0" tube, plated 1/4" dia. wire. Wt. 1.0 LB</p>	

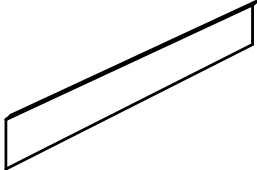
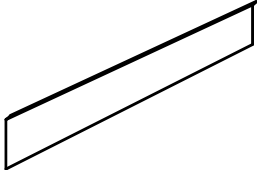
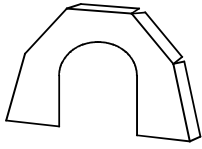
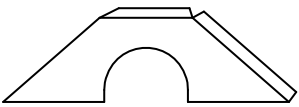
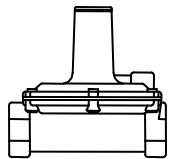
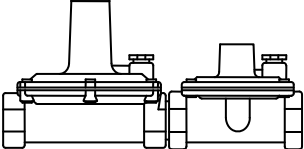
Part No.	Description	Image
0363.00	DEEP DISH REFLECTOR - Aluminum, 10' long. Wt. 5.75 lbs.	
0364.00	DEEP DISH COMBINATION HANGER - Heat tube & deep dish reflector hanger for 3.5" tube, plated 1/4" dia. wire. Wt. 0.75 lb.	
0464.00	DEEP DISH COMBINATION HANGER - Heat tube & deep dish reflector hanger for 4.0" tube, plated 1/4" dia. wire. Wt. 0.75 lb.	
0365.00	DEEP DISH REFLECTOR SUPPORT - Intermediate support for deep dish reflector for 3.5" tube, plated 1/4" dia. wire. Wt. 0.75 lb.	
0465.00	DEEP DISH REFLECTOR SUPPORT - Intermediate support for deep dish reflector for 4.0" tube, plated 1/4" dia. wire. Wt. 0.75 lb.	
0366.00	SIDE SHIELD - Aluminum side shield. Used on 0361 reflectors, 10' long. Wt. 5.0 lbs.	
0367.00	SIDE SHIELD - Aluminum side shield. Used on 0360 & 0812 reflectors, 10' long. Wt. 3.0 lbs.	
0363.WH	REFLECTOR END CAP - Aluminum end cap. Used on 0363.00 reflectors. Wt. 0.50 lbs	
0342.WH	REFLECTOR END CAP - Aluminum end cap. Used on 0360.00 reflectors. Wt. 0.25 lbs.	
5221.00	HIGH PRESSURE REGULATOR - For Natural gas, 2 lbs. to 7.0" W.C., 1/2" NPT Wt. 1.5 lbs.	
5221.0015	HIGH PRESSURE REGULATOR - For Natural gas, 5 lbs. to 7.0" W.C., 1/2" NPT Wt. 4 lbs.	

WARRANTY STATEMENT

Combustion Research Corporation ("CRC") offers the end-use buyers of its products a specific and limited three-year standard Warranty covering the Omega II® product systems or components, the details of which are given below. This Warranty is offered only to the Buyer-For-End-Use ("Buyer") and becomes effective when the product is properly installed and maintained. Proper installation shall be assumed (for purposes of this warranty only) if installation is performed by a qualified installer in accordance with the owners manual as well as local, state and federal standards.

In addition, to the three-year warranty on all product components, Combustion Research Corporation also offers the Buyer an Extended Warranty on the radiant heater tubing (Infrared Emitter), which is installed as original equipment with a Combustion Research Corporation infrared radiant energy heating system. This Extended Warranty becomes effective (1) on the invoice date of the original equipment from CRC, and (2) the product is properly installed and maintained in accordance with the owner's manual

This Warranty is subject to limitations and conditions which affect the Buyer's rights and which can lead to voidance of the warranty. The Buyer should read and understand these limitations.

DISCLAIMER OF IMPLIED WARRANTIES

(Please Read Carefully)

COMBUSTION RESEARCH CORPORATION ("CRC") DISCLAIMS ANY AND ALL IMPLIED WARRANTIES OF ANY KIND OR DESCRIPTION, INCLUDING WITHOUT LIMITATION WARRANTIES OF MERCHANTABILITY, FITNESS FOR A PARTICULAR PURPOSE, CONDITION, QUALITY OR DURABILITY, WHICH MAY BE PROVIDED BY LAW AS RELATES TO ALL PRODUCTS MANUFACTURED, SOLD, ASSEMBLED AND/OR PROVIDED TO THE ULTIMATE USER, TRANSFEREE, CONTRACTOR, CONSUMER, BUYER AND/OR PERSON UNDER THE LAWS OF THE STATE OF MICHIGAN AND/OR THE UNIFORM COMMERCIAL CODE. THIS DISCLAIMER MEANS NO IMPLIED WARRANTY OF ANY NATURE WHATSOEVER DEALING WITH THE ULTIMATE USE OF THE PRODUCT ASSEMBLED, MANUFACTURED AND/OR SOLD BY CRC SHALL BE GRANTED TO ANY PARTY WHO WITHOUT SAID DISCLAIMER WOULD BE ENTITLED TO BRING AN APPROPRIATE ACTION IN THE COURTS OF THE STATE OF MICHIGAN AS THE LAW SO PROVIDES. THE EXPRESS WRITTEN WARRANTY OF CRC FOR EACH PARTICULAR TRANSACTION SHALL BE THE ONLY EXPRESS WARRANTIES SO PROVIDED AND SHALL BE THE ONLY WARRANTY PROVIDED BY CRC FOR ITS PRODUCTS. THERE ARE NO WARRANTIES WHATSOEVER BEYOND THE DESCRIPTION ON THE FACE HEREOF.

DISCLAIMER OF DAMAGES

(Please Read Carefully)

IN NO EVENT SHALL CRC BE LIABLE FOR SPECIAL, INDIRECT, CONSEQUENTIAL OR INCIDENTAL DAMAGES OF ANY TYPE OR DESCRIPTION WHETHER ARISING UNDER CONTRACT, WARRANTY, TORT, NEGLIGENCE, STRICT LIABILITY OR ANY OTHER THEORY OF LIABILITY. SUCH DAMAGES INCLUDE, BUT ARE NOT LIMITED TO, LOSS OF PROFITS, LOSS OF USE OF THE PRODUCTS, DAMAGE TO PROPERTY, INCONVENIENCE AND CLAIMS OF THIRD PARTIES. SOME STATES DO NOT ALLOW THE EXCLUSION OR LIMITATION OF INCIDENTAL OR CONSEQUENTIAL DAMAGES, OR ANY LIMITATION OF INCIDENTAL OR CONSEQUENTIAL DAMAGES OR ANY LIMITATIONS ON HOW LONG AN IMPLIED WARRANTY LASTS, SO THE ABOVE EXCLUSION OR LIMITATION MAY NOT APPLY TO YOU. THIS WARRANTY GIVES YOU SPECIFIC LEGAL RIGHTS WHICH VARY FROM STATE TO STATE. HOWEVER, TO THE EXTENT PROVIDED BY LAW, MICHIGAN LAW CONTROLS ALL RIGHTS AND OBLIGATIONS HEREUNDER.

LIMITATIONS AND CONDITIONS FOR STANDARD WARRANTY

The express written Warranty is a representation by CRC that the products, including all components, purchased by the Buyer from CRC or an authorized CRC representative are free from defects in material and workmanship. This Warranty applies to defects which are discovered either upon receipt of the product, or up to three (3) years after receipt of the product or CRC's invoice date, whichever event last occurs. If any such defect is found and the Buyer has satisfied the warranty requirement, and the warranty is not voided under any of the following conditions, CRC will replace free-of-charge, the defective part or parts. However it is not CRC's obligation to find, remove, or transport the defective part or parts. Further, it is not CRC's obligation to install or to pay for installation of any replacement part or parts. Repair or replacement of defective part or parts will only be done after CRC has determined in its sole judgment that the warranty applies.

LIMITATIONS AND CONDITIONS FOR EXTENDED 10 YEAR WARRANTY

The Extended Warranty is a special offer made by Combustion Research Corporation (CRC) to Buyers-For-End-use of CRC products to give them an extra term of replacement part protection. The Extended Warranty covers the infrared emitter tubing. The infrared tubing is guaranteed by CRC against internally created rust through corrosion (which is caused by the condensation of products of combustion inside the emitter tube when the flue gas temperature is allowed to fall below the dew/condensation point) for 10 years from CRC's invoice date. If any defect is found during this period, and if the Buyer-For-End-Use has satisfied the Warranty and Extended Warranty requirements, and if the warranty is not voided under any of the following conditions, CRC's obligation is either repair the defective part or to furnish the Buyer-For-End-Use with a

- CONTINUED-

replacement part or parts. As with the Standard Warranty, it is not CRC's obligation to find, remove or transport the defective part or parts, or to pay for finding, removing, or transporting such part or parts, and it is not CRC's obligation to install or pay for installation of the replacement part or parts. Again, it is the Buyer's obligation to send the part or parts freight pre-paid to CRC.

LIMITATIONS ON STANDARD AND EXTENDED 10 YEAR WARRANTY

These Warranties are the only warranties offered by Combustion Research Corporation (CRC) and are in lieu of all other warranties either express or implied. CRC shall not be liable for any special, incidental or consequential damage, such as damage to a building or persons or things within a building due to any kind of radiant energy heating system failure. In addition, the Standard and Extended Warranties apply only to those products which are shipped to and installed in the United States.

ARBITRATION

In the event any Buyer, user, subsequent owner, transferee, installer, purchaser and/or ultimate customer experiences any problem, difficulty and/or has a complaint dealing with the use, installation and/or operation of the products sold, delivered and/or manufactured by CRC under the terms and provisions of any purchase order, contract, invoice or other document, then the differences between that person or entity and CRC shall be amicably resolved. In the event a resolution of the differences between the parties is unable to be accomplished, said matter shall be resolved through final and binding arbitration under the laws of the State of Michigan. The party complaining shall select, appoint and pay for an arbitrator. CRC shall select, appoint and pay for an arbitrator, and the two (2) arbitrators so selected shall agree upon and appoint a third impartial arbitrator. The dispute and/or matter of controversy shall be submitted to the arbitrators who by majority vote shall render a final and binding decision dealing with the controversy in existence between the parties. Said decision shall be enforceable in a Michigan Court maintaining jurisdiction over said matter under the requisite provisions of Michigan law. The costs of the impartial arbitrator shall be paid one-half (1/2) by the complaining party and one-half (1/2) by CRC.

MICHIGAN LAW TO GOVERN

This contract and/or document dealing with the purchase sale and/or installation of products sold and/or manufactured by CRC shall be governed by the laws of the State of Michigan, both as to its interpretation and performance. The place of this contract, its situs and forum shall at all times be the State of Michigan. All matters relating to the validity, construction and enforcement of this contract shall be determined in the appropriate courts maintaining jurisdiction over all controversies in the State of Michigan.



VOIDING OF WARRANTIES

Each of the following listed events, conditions, acts or omissions by any person or entity may void the Warranty:

1. Improper installation; i.e., installation which is not in accordance with the instructions in the service and installation manual.
2. Running the burner(s) with intake combustion air drawn from an atmosphere which is contaminated with halogenated hydrocarbons, fluorocarbons, or other corrosive substances.
3. Relocation or reinstallation of the product or system.
4. Use of electrical power having voltages, frequencies or transients which exceed product or system ratings.
5. Physical abuse or neglect to the product system or components of the system; i.e., allowing the product system to operate with broken or damaged system components.
6. Damage to the product system or components of the product system by fire, flood, earthquake or act of God.
7. Removal of the serial number or nameplate.
8. Refusal to permit inspection and/or service of the product system or parts by an authorized CRC representative.
9. Repair or replacement of any product components or other heating components which have been repaired or replaced with other than factory parts.
10. Designing or allowing the system to run with a "short cycle" or continuous condensing mode; i.e., using low voltage temperature controls without a minimum eight (8) minute run time which would allow the startup condensate to collect in the tubing system.

The determination and evaluation of any or all of the above conditions shall be according to the sole and exclusive discretion of CRC, and/or its authorized representative. If, upon examination, either CRC or its authorized representative determines that the defect or defects are caused by any of the above, the warranty obligation of CRC shall not be honored. No representative of CRC, other than an officer, has authority to change or extend these provisions or warranties. Changes or extensions shall be binding only if confirmed in writing by CRC's duly authorized executive officers. Product systems installed by CRC or its authorized representatives shall be or presumed to be properly installed and to be free of any and all conditions which might void the warranty at the time of installation. All product components or systems repaired or replaced are warranted under the same terms and conditions as the original Warranty, but only for the remaining time under the original warranty. No action shall be brought for any breach of this warranty more than one (1) year after the cause of action for such breach arises. Nothing herein shall be construed to extend any warranty beyond the stated periods. CRC shall not be liable for any default or delay in performance by it in accordance with these warranties which delay or performance is caused by contingency beyond its control including but not limited to war, government restriction or restraint, strikes, fire, floods, unavailability of raw material, and acts of God.

In storage areas where stacking of materials may occur, the installer must provide signs that specify the maximum stacking height so as to maintain the required clearance to combustibles. The following is a temporary sign that can be used until a permanent label is obtained from your representative or Combustion Research Corporation - Request P/N 5566.006. Attach this label near the Reflect-O-Ray® heater or by the thermostat.

	COMBUSTION RESEARCH CORP.		
Infrared Heating Systems			
⚠ WARNING			
	Fire Hazard Some objects can catch fire or explode when placed close to the heater. Keep all flammable objects, liquids and vapors the required clearance to combustibles away from the heater. Failure to follow these instructions can result in death, injury or property damage.		
Maintain _____ clearance to the side and _____ clearance below the heater from vehicles and combustible materials.			
Read and understand the Installation, Operation and Maintenance manual before installation, operation or service.			
Know your heater part number, and BTU input. The Part Number and BTU Input and clearance to combustible information can be found on the burner assembly and in the Installation, Operation and Maintenance manual.			
Write the largest clearance dimensions with permanent marker, according to the heater used, in the open spaces above.			
Combustion Research Corp. - 2516 Leach Rd. - Rochester Hills, MI 48309-3555 Telephone: 248.852.3611 Fax: 248.852.9165 www.combustionresearch.com			
Printed in U.S.A	Revision Date:	Rev. 0	P/N 5566.006

