

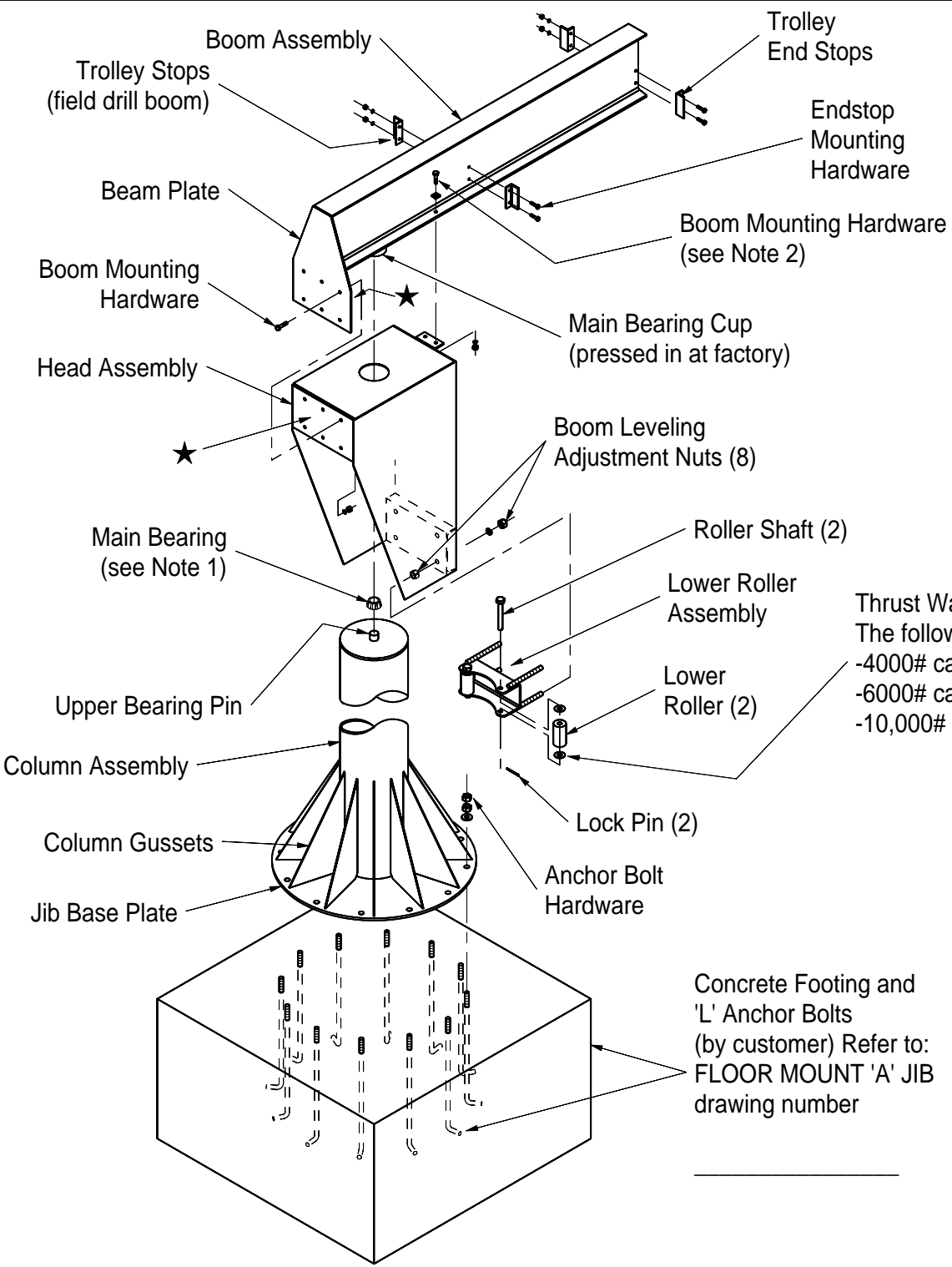

1377 Kimberly Drive
 Neenah, WI 54956-1642
 Office (920) 722-0101
 Fax (920) 725-1394
 www.contrx.com

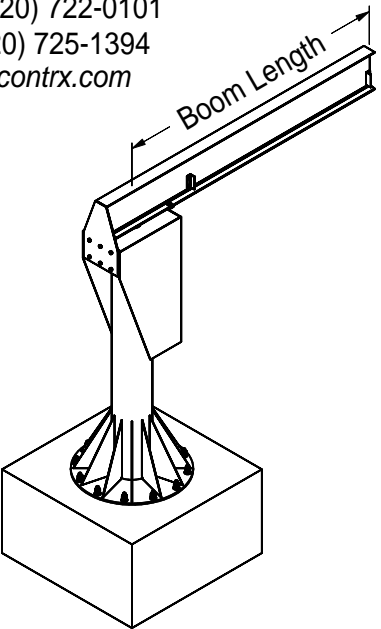

Thrust Washer (4)
 The following models have (2):
 -4000# cap. with longer than 16'-0" boom-
 -6000# cap. with longer than 10'-0" boom-
 -10,000# cap. all boom lengths-

Note 1:
 Complete bearing assembly factory installed in the Boom Assembly on the following models:
 -4000# cap. with longer than 16'-0" boom-
 -6000# cap. with longer than 10'-0" boom-
 -all 10,000# cap. A-jibs-

Note 2:
 Beveled washers are to be used on tapered flange beams only.

★ Note 3: For orders with similar multiple cranes, look for markings on the inside of the beam plate and the matching face of the head assembly. This will insure the correct parts are matched up.

'A' Jib Assembly Detail	
02-8-16 Not to scale	DWG NO
	A-1005-A