



FF61BI



33.25" x 23.63" x 23" (H x W x D)

Built-in undercounter all-refrigerator for residential use, auto defrost with white exterior

Highlights:

Flexible design allows built-in or freestanding use in 24" spaces

Includes adjustable glass shelves for spill-proof storage

Deluxe interior includes a scalloped wine shelf

Door racks provide convenient storage options

Product Features:

Slim undercounter dimensions	Ideal 24" footprint offers full 5.5 cu.ft. storage capacity in a slim fit
Built-in capable	Make the best use of space by installing your appliance under the counter and flush with other cabinets
Automatic defrost	Reduced user maintenance with automatic defrost operation
Adjustable glass shelves	Rearrange your refrigerator space to accommodate all shapes and sizes or remove shelves for a simple clean-up
Fruit and vegetable crisper	Get the longest life and best taste out of produce by storing it in a convenient slide drawer
Wine shelf	Removable scalloped wine shelf is included to store champagne and wine bottles
Door storage	Keep tall bottles and condiments right on the door for convenient access
One piece interior liner	Enjoy easy clean-up with a seamless liner that won't hold a mess in hidden crevices
Hidden evaporator	Cold wall design with hidden evaporator and seamless interior



FF61BI Specifications:

Overview	
Height	33.25"
Width	23.63"
Depth	23.0"
Depth with Handle	24.63"
Depth with door at 90°	45.38"
Capacity	5.5 cu.ft.
Defrost Type	Automatic
Door	White
Cabinet	White
US Electrical Safety	UL
Canadian Electrical Safety	ULC
Energy Usage/Year	307.0kWh/year
Amps	1.0
Weight	100.0 lbs.
Shipping Weight	110.0 lbs.
Parts & Labor Warranty	1 Year
Compressor Warranty	5 Years
Refrigerator Features	
Door Swing	RHD
Reversible	Yes
Crisper Qty	1
Crisper Finish	Opaque
Crisper Cover	Wire
Shelf Type	Glass
Shelf Qty	3
Full Door Shelf Qty	3
Adjustable Shelves	Yes
Wine Bottle Shelves	Yes
Thermostat Type	Dial
Fan Type	Exterior
Refrigerant Type	R134a
Refrigerant Amount	1.7oz.
High Side PSI	285.0
Low Side PSI	70.0
Level Legs Qty	4
Interior Light	Yes
Dimensions	
Interior Height	26.25"

Interior Width	21.0"
Interior Depth	18.0"
Compressor Step Height	5.5"
Compressor Step Width	21.0"
Compressor Step Depth	6.0"

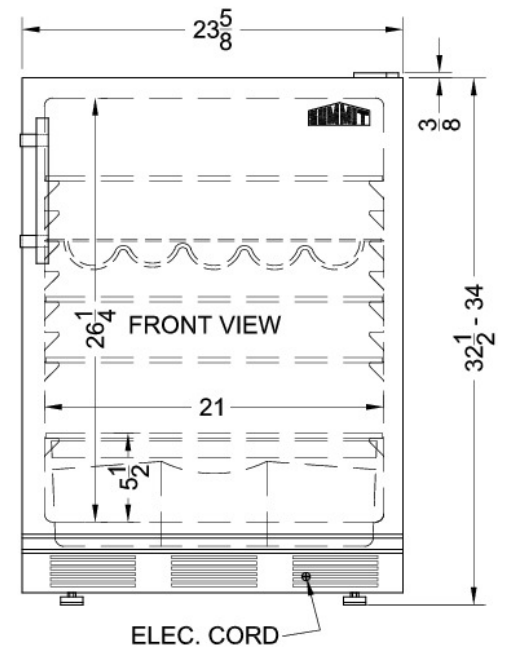
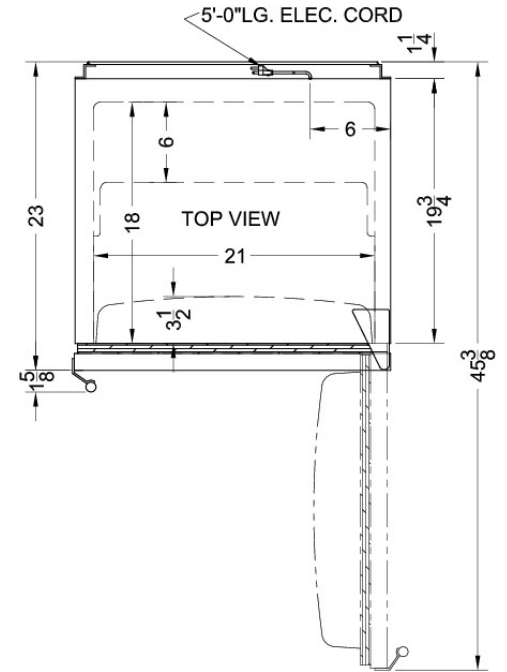

SUMMIT APPLIANCE DIVISION FELIX STORCH, INC.

770 Garrison Avenue, Bronx, NY 10474 USA TEL 718-893-3900 FAX 844-478-8799 info@summitappliance.com www.summitappliance.com