

**REFRIGERATOR MANUFACTURER**  
**Turbo air**  
 more durable, efficient, beautiful

4184 E. Conant St.  
 Long Beach, CA 90808  
 Tel. 310-900-1000  
 Fax. 310-900-1077  
[www.turboairinc.com](http://www.turboairinc.com)

Project :	
Model # :	
Item # :	Qty :
Available W/H :	
Approval :	

## Solid Door Freezer

Reach-In Top Mount  
**M3 Series**

**Model : M3F72-3**

### FEATURES & BENEFITS

- **Digital temperature control system**  
 Provides precise and constant temperature. This level of precision allows food products to remain fresh over an extended period of time.
- **High-tech monitor**  
 The monitor digitally displays the present temperature. You can easily change the temperature by adjusting the digital temperature controller.
- **Hot gas condensate system**  
 Through Turbo Air's creative innovation, the condensate system surfaces have been specially treated to resist corrosion. This not only increases efficiency without the risk of refrigerant leakage from corrosion, but also prevents the overflow of condensate water.
- **Door pressure release device**  
 Pressure relief doors are designed to eliminate vacuum pressure and allows easy, instant door opening.
- **LED interior lighting system**  
 Brighter and longer lasting LED lights provide attractive, enhanced illumination compared to fluorescents. It saves energy by producing less heat, while maximizing the visibility.
- **Efficient refrigeration system**  
 M3's solid door freezers are designed with oversized and balanced (CFC Free R-404A) refrigeration systems. These include efficient evaporators and condensers for faster freezing and greater efficiency.
- **Stainless steel cabinet construction**  
 The Turbo Air M3 freezer model boasts a stainless steel exterior (galvanized steel top, bottom and back) and stainless steel interior with AL inside walls and door liners. It guarantees the utmost in cleanliness and long product life. Unlike other companies' products, the sharp corners and edges have been rounded to reduce the risk of injury. The M3 can add a touch of style to the most refined setting.
- **Adjustable, heavy duty, PE(polyethylene) coated wire shelves**
- **High-density polyurethane insulation**  
 The entire cabinet structure and solid doors are foamed-in-place using high density, CFC free polyurethane insulation.
- **Automatic evaporator fan motor delays**  
 When the door is opened the evaporator fan will stop, preventing the circulation of hot and moist air from escaping into the refrigerator. This increases energy efficiency and lengthens the life of the compressor.
- **Magnetic door gaskets**  
 Magnetic door gaskets are of one piece construction, removable without tools for ease of cleaning and replacement.

**3 YEAR PARTS & LABOR WARRANTY**



**Freezer holds -10°F ~ 0°F for the best in frozen food preservation**



Model	Swing Door	CU./FT.	#of Shelves	HP	AMPS	Crated Weight (lbs.)	L x D* x H † (inches)
M3F72-3	3	72	9	1 1/4	10.4	571	77 3/4 x 30 3/4 x 78

## Model : M3F72-3

ELECTRICAL DATA	
Voltage †	115/208~230/60/1
Plug Type †	☺ NEMA-L14-20
Full Load Amperes	10.4
Compressor HP	1 1/4
Feed Wires with Ground	4
Cord Length (ft.)	9
Refrigerant	R-404A
DIMENSIONAL DATA	
# of Doors	3
# of Racks Accepted	3
Net Capacity (cu. ft.)	72
Ext. Length Overall (in.)	77 3/4 (1975mm)
Ext. Depth Overall (in.) *	30 3/4 (780mm)
Ext. Height Overall (in.) †	78 (1981mm)
Int. Length Overall (in.)	73 7/8 (1877mm)
Int. Depth Overall (in.)	26 1/2 (675mm)
Int. Height Overall (in.)	60 5/8 (1539mm)
Gross Weight (lbs.)	571
# of Shelves	9
Shelf Size (L x D) (in.)	23 1/2 x 25 1/4 23 1/2 x 23 1/8, 23 1/2 x 25 1/4

Design and specifications subject to change without notice.

Actual shipping weight may differ due to extra packing materials for product protection.

\* Depth does not include 2" for rear condensate enclosure.

† Height does not include 5" for caster height.

‡ M3F72-3 requires 115/208-230/60Hz, single phase, 3 pole, 4 wire circuit. (NEMA-L14-20)

■ **WARRANTY : 3 Year Parts and Labor Warranty**  
Additional 2 Year Warranty on Compressor

- **Self-contained system**
- **Standard 4" dia. swivel casters with locks on the front set**
- **Door locks standard**
- **Solid and sturdy grille design**

■ **OPTIONAL ACCESSORIES :**

- 5" diameter swivel casters
- 6" height stainless steel legs
- Additional PE coated wire shelves
- Half door bun tray racks.  
Each holds up to seven 18"L x 26"D sheet pans (sold separately)
- Full door bun tray racks.  
Each holds up to fifteen 18"L x 26"D sheet pans (sold separately)

## PLAN VIEW

(unit : inch)

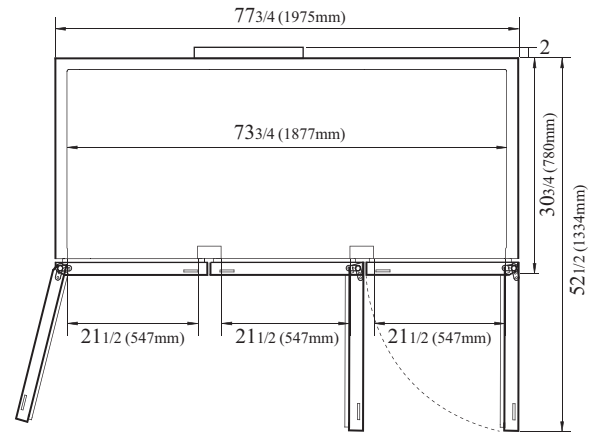

PLAN VIEW

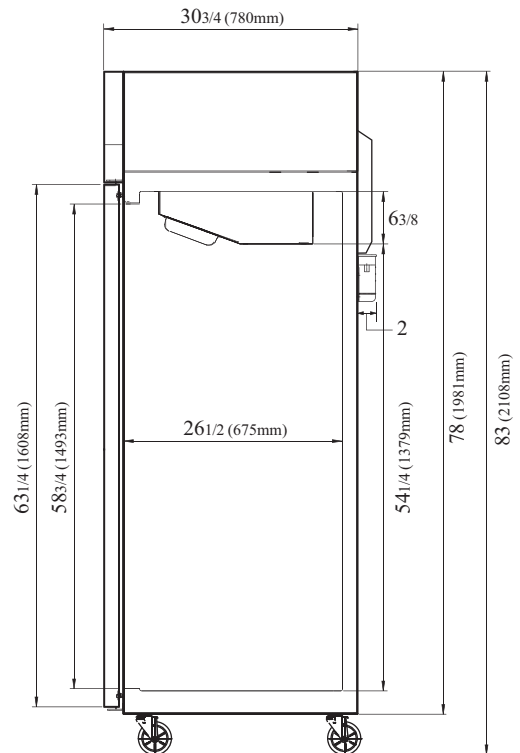

SIDE VIEW

Ver.201509



ENERGY STAR®  
Qualified

- Turbo Air : 800-627-0032
- GK : 800-500-3519
- Warranty : 800-381-7770
- AC : 888-900-1002

