

- **Available in 36" and 48" Wide Models Both with Under Shelf and Cantilever Shelf**
- **16 Gauge Stainless Steel Construction**
- **Space Saver**
Folds Up to be Moved and/or Stored for Easy Clean Up
- **Work Surface Weight Capacity - 500 lbs. (Evenly Distributed Load)**
- **24" Deep Work Surface has 1 3/4" Backsplash on Three (3) Sides**
- **Safety Pins Provided for Added Security**
- **Wall Mount Model Comes Fully Assembled**
With Mounting Hardware for Drywall and Stud Installation
Mounts 6" off the Floor
- **Make Unit Mobile by Adding Optional Caster Base***
Minimal Assembly Required
Four (4) 3" x 1 1/4" Swivel Locking Caster (CDL3)

*See page 36 for more information on mobile units



RTW246036 (Closed)



Add additional work or prep space when you need it...and floor space when you don't!

Click here to watch a video!

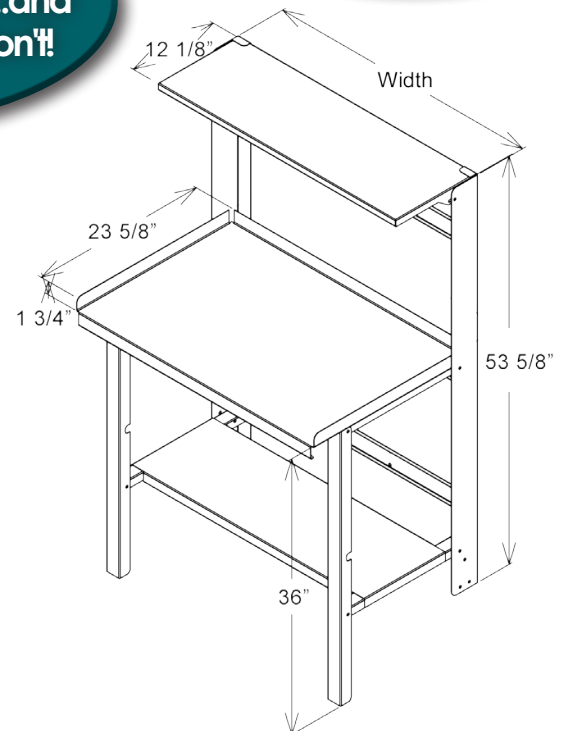

24" Retractable Prep Stations

Model Number	Closed Size* D x H x W	Opened Size D x H x W	Weight
RTW246036	5 1/4" x 60" x 36"	24" x 60" x 36"	68
RTW246048	5 1/4" x 60" x 48"	24" x 60" x 48"	82

*Closed height is measured from floor level to top of product.

Optional Caster Bases

Model Number	Description
RT36C	36" Caster Base; Compatible with RTW246036
RT48C	48" Caster Base; Compatible with RTW246048

