

SCFU386



24" x 23.38" x 20.63" (H x W x D)

Countertop commercial freezer with self-closing door; replaces SCFU385

Highlights:

Commercially listed for use in foodservice establishments

Self-closing door is ideal for busy commercial settings

Glass door offers full display to boost impulse sales

Factory installed lock provides security you can count on

Product Features:

| | |
|----------------------------|---|
| Commercially approved | ETL-S listed to NSF standards for commercial use |
| Factory installed lock | Keyed security for a secure interior |
| Self-closing door | Ideal for busy commercial settings, where customers and staff don't always have the chance to ensure the door is closed |
| LED lighting | Switchable light illuminates whole interior |
| Glass door | Provides a full display of stored contents |
| Removable shelves | Two wire shelves included |
| Adjustable thermostat | Rear mounted to prevent accidental adjustments |
| Manual defrost | Static cooling system for improved temperature stability |
| Designed to operate at 0°F | Temperature range: -4 to 5°F |



SCFU386 Specifications:

| Overview | |
|----------------------------|----------------|
| Height | 24.0" |
| Height to Hinge Cap | 24.5" |
| Width | 23.38" |
| Depth | 20.63" |
| Depth with door at 90° | 42.0" |
| Capacity | 2.0 cu.ft. |
| Defrost Type | Manual |
| Door | Glass |
| Cabinet | Gray |
| US Electrical Safety | ETL |
| Canadian Electrical Safety | ETL-C |
| Sanitation | ETL-S |
| Amps | 4.0 |
| Voltage/Frequency | 115 V AC/60 Hz |
| Weight | 83.0 lbs. |
| Shipping Weight | 95.0 lbs. |
| Parts & Labor Warranty | 1 Year |
| Compressor Warranty | 5 Years |
| Freezer | |
| Door Swing | RHD |
| Reversible | No |
| Interior Height | 18.0" |
| Interior Width | 18.75" |
| Interior Depth | 15.38" |
| Shelf Type | Wire |
| Shelf Qty | 2 |
| Adjustable Shelves | Yes |
| Thermostat Type | Dial |
| Interior Light | Yes |
| Fan Type | Interior |
| Refrigerant Type | R134a |
| Refrigerant Amount | 3.18 oz. |
| High Side PSI | 280.0 |
| Low Side PSI | 90.0 |
| Compressor Step Height | 8.25" |
| Compressor Step Width | 18.75" |
| Compressor Step Depth | 7.0" |

Temperature Range

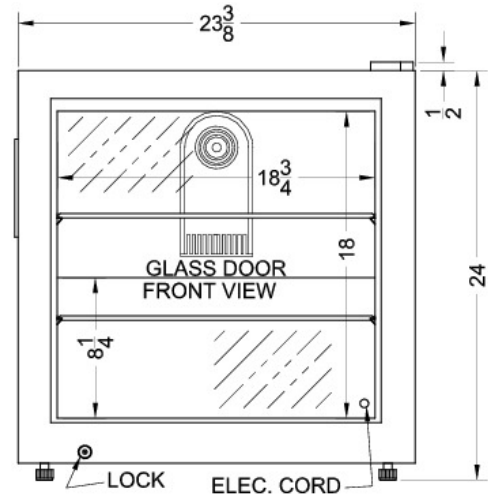
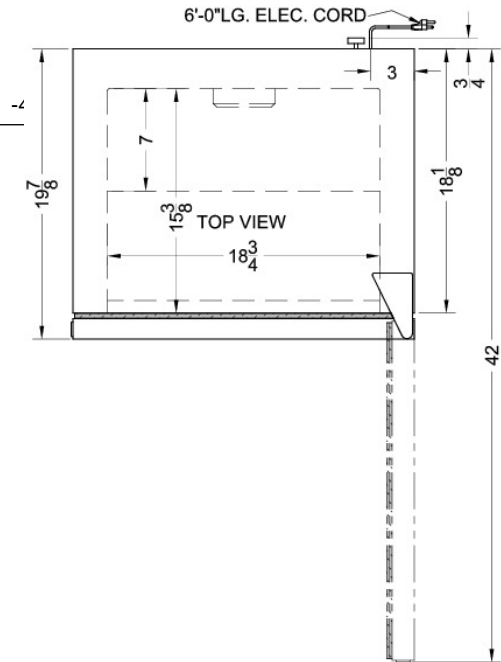

SUMMIT APPLIANCE DIVISION FELIX STORCH, INC.

770 Garrison Avenue, Bronx, NY 10474 USA TEL 718-893-3900 FAX 844-478-8799

info@summitappliance.com

www.summitappliance.com