

SCR312LPUB



25.5" x 17" x 18.5" (H x W x D)

Commercial glass door pub cellar for countertop use, with digital thermostat and lock

Highlights:

Commercially approved and CalCode compliant

Ideal for storing red wine and ales at a warmer temperature setting

Fast temperature recovery for safer storage

Interior LED lighting for an elegant display with energy efficiency

Product Features:

Commercially approved	ETL-S listed to NSF-7 commercial standards
Double pane tempered glass door	Heat resistant design provides clear view of stored products, with an elegant trim in stainless steel
Factory installed lock	Keyed lock for secure interior
Professional handle	17 1/2" long handle in brushed aluminum
Automatic defrost	Reduced user maintenance with auto defrost system
Wide range digital thermostat	Precise temperature management at the touch of a button, with an external display for added convenience (temperature range: 40°F to 72°F)
Recessed LED lighting	Externally located button turns this light on and off to illuminate the products for a tempting view
Adjustable chrome shelves	Rearrange refrigerator space to accommodate all sizes or remove shelves for simple cleanup
Countertop dimensions	Perfectly sized for any location



SCR312LPUB Specifications:

Overview	
Height	25.5"
Height to Hinge Cap	26.13"
Width	17.0"
Depth	18.5"
Depth with Handle	20.25"
Depth with door at 90°	34.5"
Capacity	2.5 cu.ft.
Defrost Type	Automatic
Door	Glass
Cabinet	Black
US Electrical Safety	ETL
Canadian Electrical Safety	ETL-C
Sanitation	ETL-S
Amps	1.3
Voltage/Frequency	115 V AC/60 Hz
Weight	80.0 lbs.
Shipping Weight	100.0 lbs.
Parts & Labor Warranty	1 Year
Compressor Warranty	5 Years
Wine Cellar	
Number of Zones	1
Door Swing	RHD
Reversible	No
Adjustable Shelves	Yes
Shelf Type	Wire
Shelf Qty	4
Thermostat Type	Digital
Interior Light	Yes
Refrigerant Type	R134a
Refrigerant Amount	1.82 oz.
High Side PSI	270.0
Low Side PSI	103.0
Interior Height 1	21.5"
Interior Depth 1	14.0"
Compressor Step Height	7.5"
Compressor Step Width	14.0"
Compressor Step Depth	5.0"

Level Legs	2
Interior Height 2	14.63"

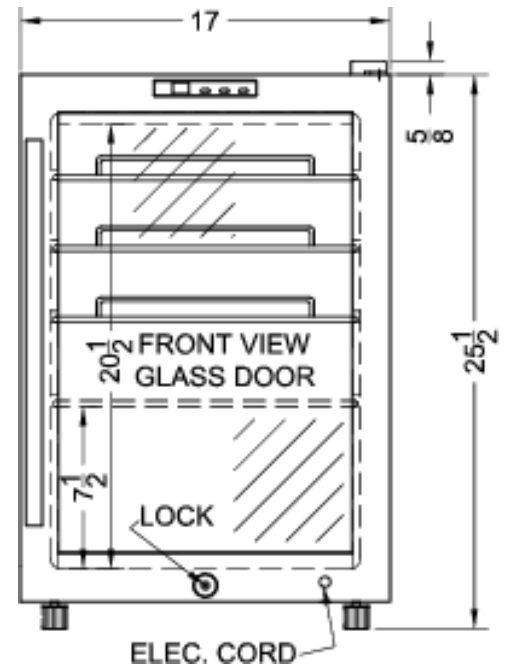
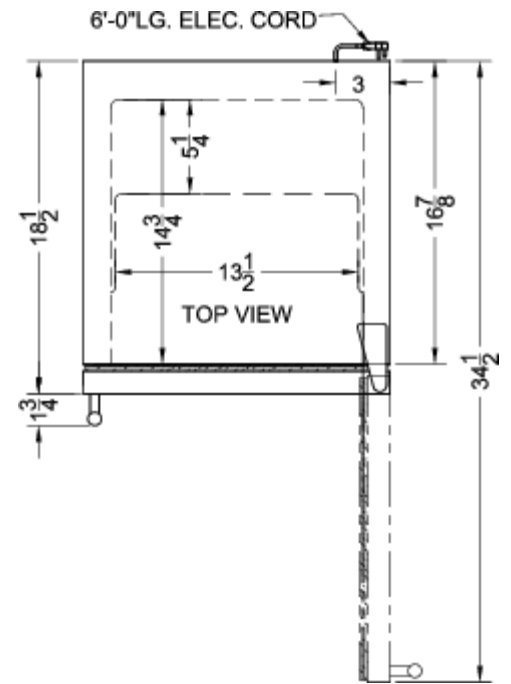

SUMMIT APPLIANCE DIVISION FELIX STORCH, INC.

770 Garrison Avenue, Bronx, NY 10474 USA TEL 718-893-3900 FAX 844-478-8799 info@summitappliance.com www.summitappliance.com