

REFRIGERATOR MANUFACTURER
Turbo air
 more durable, efficient, beautiful

4184 E. Conant St.
 Long Beach, CA 90808
 Tel. 310-900-1000
 Fax. 310-900-1077
www.turboairinc.com

Project :	
Model # :	
Item # :	Qty :
Available W/H :	
Approval :	

Beer Dispensers

*Underbar Equipment
 Super Deluxe Series*

**3 YEAR PARTS & LABOR
 WARRANTY**

Model : TBD-3SD/SB



TBD-3SD



TBD-3SB

- Does not include keg couplers

≡ FEATURES & BENEFITS ≡

- **Efficient refrigeration system**
 Turbo Air's refrigerators are designed with oversized and balanced R-134A (CFC Free) refrigeration systems. These include efficient evaporators and condensers for faster cooling and greater efficiency.
- **Forced air cooling system**
 Fast cooling and balanced temperature throughout the cabinet.
- **Stainless steel cabinet construction**
 Super Deluxe (SD) models boast a stainless steel exterior (except galvanized steel back and bottom). SB models are attractive wear-resistant black vinyl exterior. Heavy gauge stainless steel countertop is perfect for sanitation and durability. Interior is stainless steel except galvanized steel top. Turbo Air Beer Dispenser model guarantees utmost in cleanliness and long product life. It also can add a touch of style to the most refined setting.
- **High-density polyurethane insulation**
 The entire cabinet structure is foamed-in-place using high density, CFC free polyurethane insulation.
- **3" diameter stainless steel insulated beer columns**
- **Ergonomically designed doors**
 Customers' fatigue fades away with easy grip handles and doors that open effortlessly. These features along with self-closing doors make this the ultimate choice in customer convenience.
- **Side mount compressor unit**
 By positioning the compressor on the side of the unit, refrigerators can now be serviced without being moved. Our innovative, front breathing feature also allows this model to provide high efficiency in narrow spaces.
- **LED lighting interior display system**
 Brighter and longer lasting LED lights provide attractive, enhanced illumination compared to fluorescents. It saves energy by producing less heat.
- **Refrigerator holds 33°F ~ 38°F for the best in beverage preservation**

‡ ENERGY STAR rated models



Model	Swing Door	1/2 Barrels	HP	AMPS	Crated Weight (lbs.)	L x D* x H† (inches)
TBD-3SD ‡	2	3	1/3	7	338	69 1/8 x 27 1/8 x 37
TBD-3SB ‡	2	3	1/3	7	348	69 1/8 x 27 1/8 x 37

Model : TBD-3SD/SB

ELECTRICAL DATA	
Voltage	115/60/1
Plug Type	Ⓜ NEMA 5-15P
Full Load Amperes	7
Compressor HP	1/3
Refrigerant	R-134A
Cord Length (ft.)	9
Lamp (w)	25W
DIMENSIONAL DATA	
Cubic feet (1/2 Barrels)	3
Ext. Length Overall in.	69 1/8 (1758mm)
Ext. Depth Overall in.*	27 1/8 (691mm)
Ext. Height Overall in.†	37 (940mm)
Net Weight lbs.	298
Gross Weight lbs.	338/348
# of Swing Door	2

Design and specifications subject to change without notice.
Actual shipping weight may differ due to extra packing materials for product protection.
* Depth does not include 2" for rear spacers.
† Height does not include 5" for caster height. Height does not include 15-1/8" for draft arm.

■ **WARRANTY : 3 Year Parts and Labor Warranty
Additional 2 Year Warranty on Compressor**

- Double faucet beer tower standard
- Door locks standard
- Self-contained system
- 4" swivel casters standard
- 2" casters available (optional)
- 6" adjustable legs available (optional)

PLAN VIEW

(unit : inch)

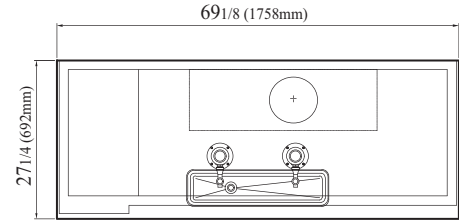

TOP VIEW

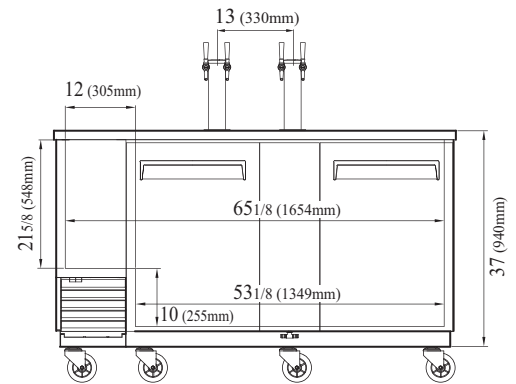

FRONT VIEW

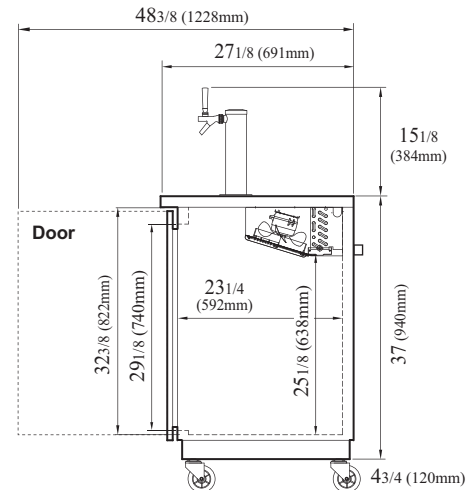

SIDE VIEW

Ver.201509



- Turbo Air : 800-627-0032
- GK : 800-500-3519
- Warranty : 800-381-7770
- AC : 888-900-1002