

REFRIGERATOR MANUFACTURER
Turbo air
 more durable, efficient, beautiful

4184 E. Conant St.
 Long Beach, CA 90808
 Tel. 310-900-1000
 Fax. 310-900-1077
www.turboairinc.com

Project :
 Model # :
 Item # : Qty :
 Available W/H :
 Approval :

Horizontal Open Display Cases

Slim Line
 Glass Side Panel / Solid Side Panel

NO PLUMBING REQUIRED

Model : TOM-50S(B) / TOM-50S-SP(-A)



TOM-50SB



TOM-50S



TOMD-H
 Top display dry case
 available (optional)



TOM-S-SP-A
 Solid side panel available



TOM-SB-SF *
 Stainless steel front panel
 available (optional)

≡ FEATURES & BENEFITS ≡

■ **Modern design**

By integrating great contours with durable structures, our modern style product designs are user-friendly while maintaining the highest product visibility and aesthetics. Glass front shield and side walls optimize the merchandiser's display effects of fresh salads, sandwiches, desserts and beverages. Its elegant contemporary euro design will enhance any store application.

■ **LED lighting interior display system**

Brighter and longer lasting LED lights provide attractive, enhanced illumination compared to fluorescents. It saves energy by producing less heat, while maximizing the visibility in the display area.

■ **Solid side panels used to ensure durability (TOM-S-SP-A models)**

■ **Interior materials available in two standards (TOM-S-SP-A models)**

Stainless steel interior for sanitary purposes or black coated interior with mirrored sides for maximized display effects.

■ **Designed to enhance impulsive sales**

Ideal for eye-catching displays and convenient access with fast service in high traffic area.

■ **Environmentally friendly, efficient refrigeration system**

Turbo Air's refrigerators are designed with oversized and balanced environmentally friendly R-134A (CFC Free) refrigeration. These include large evaporators and condensers for faster cooling and balanced temperature throughout the cabinet.

■ **Non-peel, durable anti-rust coating on the exterior reduces fingerprints**

■ **Standard back-guard improves airflow**

■ **300 series stainless steel interior standard including back wall, shelves and deck pans**

■ **Perforated interior back wall and top for improved air flow**

■ **Foamed with polyurethane, high-density cell insulation (CFC free)**

■ **Front air intake and rear air discharge**

■ **Stainless steel front panel available for all model (optional)**

■ **Recommended operating conditions**

TOM models are designed to operate in an environment where temperature & humidity do not exceed 75°F and 55% respectively. Units should not be installed near HVAC vents, fans or doorways that will disrupt the air curtain and compromise the function of the cabinet. Air curtain models will run most efficiently when completely loaded with product.



Model	CU./FT.	# of Bottom Shelves	HP	AMPS	Crated Weight (lbs.)	L x D x H (inches)
TOM-50S(B) TOM-50SB-SP(-A)	8.7	3	1/2	11	481	50 3/4 x 34 5/8 x 41 1/2

Horizontal Open Display Cases

Slim Line
Glass Side Panel / Solid Side Panel

Model : TOM-50S(B) / TOM-50S-SP(A)

ELECTRICAL DATA	
Voltage	115/60/1
Plug Type	Ⓜ NEMA 5-15P
Full Load Amperes	11
Compressor HP	1/2
Refrigerant	R-134A
DIMENSIONAL DATA	
Net Capacity (cu. ft.)	8.7
Ext. Dimension (L x D x H) (in.)	50 ³ / ₄ x 34 ⁵ / ₈ x 41 ¹ / ₂
Int. Dimension (L x D x H) (in.)	48 ³ / ₈ x 24 x 13
Net Weight (lbs.)	370
Gross Weight (lbs.)	481
# of Bottom Shelves	1
Shelf Size (Top) (in.)	48 ¹ / ₄ x 7 x 2 ¹ / ₂
Shelf Size (Middle) (in.)	48 ¹ / ₄ x 14 ¹ / ₈ x 3 ¹ / ₄
Shelf Size (Low) (in.)	48 ¹ / ₄ x 9 ³ / ₄ x 3 ¹ / ₄

Design and specifications subject to change without notice.
Actual shipping weight may differ due to extra packing materials for product protection.

■ **WARRANTY : 2 Year Parts and Labor Warranty**
Additional 3 Year Warranty on Compressor

- Simple plug-in installation
- Patented self-contained system, no plumbing required
- Glass side panel - White and black color come standard
- Solid side panel - Standard color comes in black only

■ **OPTIONAL ACCESSORIES :**

- Top display dry cases (TOMD-H) available in all sizes
- Stainless steel front panel available (extra lead time will apply)
- Night cover available (white / black)

■ **TOMD-50-H : 50" Non-Refrigerated top display case for slim line**

Ext. Dimension (L x D x H) (in.)	50 ³ / ₄ x 12 ¹ / ₄ x 17 ³ / ₄
Int. Dimension (L x D x H) (in.)	48 ³ / ₈ x 9 ¹ / ₈ x 15 ⁷ / ₈
Net Capacity (cu. ft.)	4
# of Shelves (Shelf size (in.))	1 (48 ¹ / ₄ x 7)
Crated Weight (lbs.)	87

PLAN VIEW

(unit : inch)

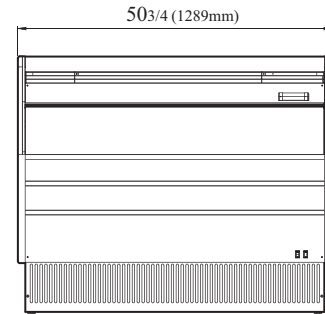

FRONT VIEW

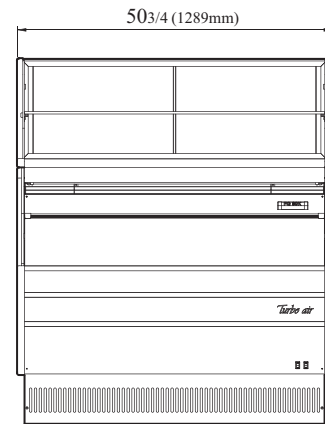

FRONT VIEW (W/ TOMD)

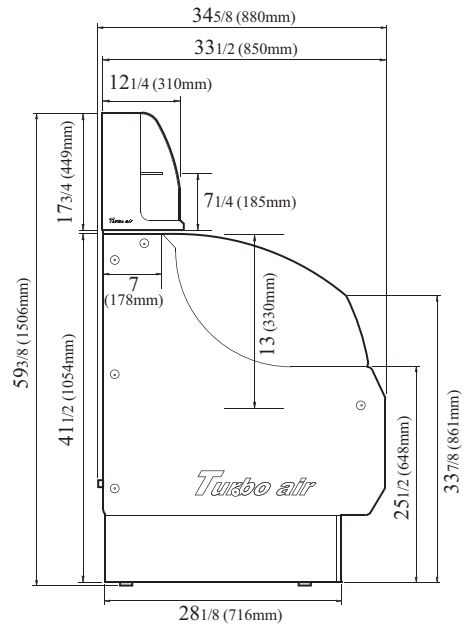

SIDE VIEW (W/ TOMD)

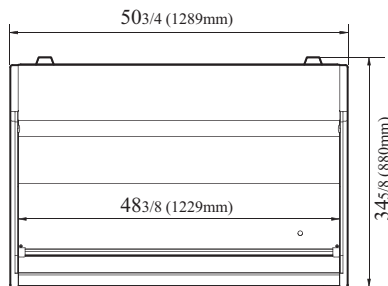

TOP VIEW

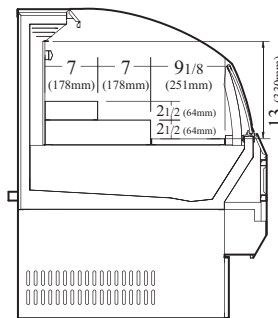

SIDE VIEW (INSIDE)

Ver.201510



- Turbo Air : 800-627-0032
- GK : 800-500-3519
- Warranty : 800-381-7770
- AC : 888-900-1002

REFRIGERATOR MANUFACTURER
Turbo air

GERMAN KNIFE

RADIANCE

GREEN WORLD

AIR CONDITIONER MANUFACTURER
Turbo air