

REFRIGERATOR MANUFACTURER
Turbo air
 more durable, efficient, beautiful

4184 E. Conant St.
 Long Beach, CA 90808
 Tel. 310-900-1000
 Fax. 310-900-1077
www.turboairinc.com

Project :	
Model # :	
Item # :	Qty :
Available W/H :	
Approval :	

Sandwich / Salad Unit

Food Prep Tables - Sandwich/Salad Prep
 Super Deluxe Series

3 YEAR PARTS & LABOR WARRANTY

Model : TST-48SD



≡ FEATURES & BENEFITS ≡

- **Cold air compartment**
 Our innovative "Cold air compartment" maintains temperature evenly for each pan to preserve fresh food longer. In addition, the compartment isolates pans from the reach-in area to prevent food spillage.
- **Stainless steel cabinet construction**
 The Turbo Air Super Deluxe model boasts a stainless steel interior and exterior (galvanized steel back & bottom). It guarantees the utmost in cleanliness and long product life. The Super Deluxe can add a touch of style to the most refined setting.
- **Sturdy, clean stainless steel shelving**
 Shelves are the most important part of cleanliness as they come in direct contact with food. After a while, PVC coated wire shelves may peel, rust and lead to unsanitary conditions. Only the Turbo Air Super Deluxe series uniquely provides stainless steel shelving.
- **Convenient cutting board side rail**
 Our cutting board is 9-1/2" deep and 1/2" thick to provide ample working space, and is made of easy to use and sanitize LDPE (Low Density Polyethylene). The new side rail cutting board bracket makes it easy to secure and remove the cutting board and it accepts different sizes too (max. 1/2" thickness)
- **Hot gas condensate system**
 Through Turbo Air's creative innovation, the condensate system surfaces have been specially treated to resist corrosion. This not only increases efficiency without the risk of refrigerant leakage from corrosion, but also prevents the overflow of condensate water.
- **Insulated pan cover**
- **Efficient refrigeration system**
 Turbo Air's solid door refrigerators are designed with oversized and balanced (CFC Free R-134A) refrigeration systems. These include efficient evaporators and condensers for faster cooling and greater efficiency.
- **High-density polyurethane insulation**
 The entire cabinet structure and solid doors are foamed-in-place high density, CFC free polyurethane insulation.
- **Magnetic door gaskets**
 Magnetic door gaskets are of one piece construction, removable without tools for ease of cleaning and replacement.
- **Ergonomically designed doors**
 Customers' fatigue fades away with easy grip handles and doors that open effortlessly. These features along with self-closing doors make this the ultimate choice in customer convenience. ABS sheet door liners resist water condensation with thermal efficiency.
- **Refrigerator holds 33°F ~ 39°F for the best in food preservation**



Model	Swing Door	CU./FT.	#of Shelves	#of Pans	HP	AMPS	Crated Weight (lbs.)	L x D x H [†] (inches)
TST-48SD	2	12	2	12	1/3	6.5	273	48 1/4 x 30 x 37

Model : TST-48SD

ELECTRICAL DATA	
Voltage	115/60/1
Plug Type	Ⓜ NEMA 5-15P
Full Load Amperes	6.5
Compressor HP	1/3
Feed Wires with Ground	3
Cord Length (ft.)	9
Refrigerant	R-134A
DIMENSIONAL DATA	
Ext. Length Overall (in.)	48 1/4 (1226mm)
Ext. Depth Overall (in.) *	30 (762mm)
Ext. Height Overall (in.) †	37 (940mm)
# of Doors	2
# of Shelves	2
# of Pans	12
# of Hood	1
Net Capacity (cu. ft.)	12
Net Weight (lbs.)	243
Gross Weight (lbs.)	273

Design and specifications subject to change without notice.

Actual shipping weight may differ due to extra packing materials for product protection.

* Depth does not include 1" for rear spacers.

† Height does not include 5" for caster height.

■ **WARRANTY : 3 Year Parts and Labor Warranty**
Additional 2 Year Warranty on Compressor

- **Self-contained system**
- **Standard 4" dia. swivel casters with locks on the front set**
- **Standard 1/6 size, 4" deep condiment pans included**
- **9 1/2" deep, 1/2" thick cutting board included**

■ **OPTIONAL ACCESSORIES :**

- 2.5" dia. casters available - 1/2" diameter & 13 TPI
- 5" diameter casters
- 6" height ABS plastic legs
- Additional stainless steel shelves
- Stainless steel double overshelf available
- Door locks available (extra lead time will apply)
- External digital thermometer available (extra lead time will apply)
- Removable food covers available

PLAN VIEW

(unit : inch)

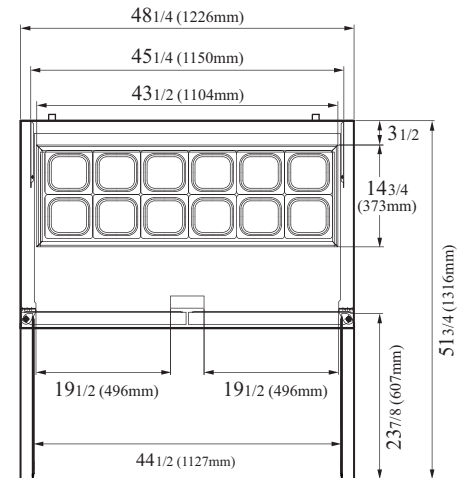

PLAN VIEW

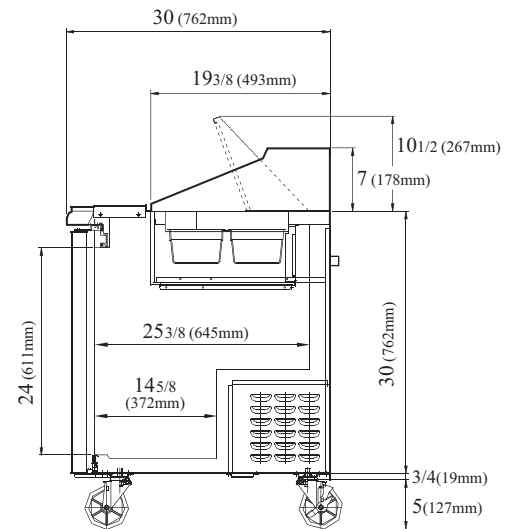

SIDE VIEW

Ver.201509



- Turbo Air : 800-627-0032
- GK : 800-500-3519
- Warranty : 800-381-7770
- AC : 888-900-1002