



BEVERAGE-AIR

3779 Champion Blvd., Winston-Salem, NC 27105
1-888-845-9800 Fax# 1-336-245-6453
<http://www.Beverage-Air.com>

CUSTOMER'S CHOICE FOR A HOT KITCHEN
Tested & Certified to Ambient Class of 100°F

3 Year Parts/Labor Warranty
Additional 2 Year Compressor Warranty

UCRY/UCF SERIES UNDERCOUNTER UNITS

Compact shallow depth undercounter refrigerators and freezers with stainless steel exterior, heavy duty construction including durable sub top, 120° stay-open field reversible doors with cartridge style hinges & snap-in door gaskets.

CABINET CONSTRUCTION

20" and 27" base models designed to fit in limited space with stainless steel exterior and aluminum interior. Heavy duty construction with durable 1/2" insulated sub-top and 2" thick CFC and HCFC-free foamed-in-place polyurethane insulation. Cartridge style hinges with black anodized aluminum pull style door handles and 120° stay-open door feature.

Snap-in-place vinyl magnetic gaskets. Standard options: 6" casters standard and 2 steel wire epoxy coated shelves per door section.

REFRIGERATION

Balanced interior forced air system with high humidity evaporator coils. Refrigeration system operates at 36° to 38°F for optimal food preservation while freezer model temperature is held at 0°F and below. Refrigerators and freezers utilize environmentally friendly refrigerants. Refrigerators use R134a and freezers use R404A refrigerants. Both are CFC and HCFC-free providing full compliance with environmental safety standards.

ELECTRICAL

Units wired at factory and ready for connection to a 115/60/1 phase, 15 amp dedicated outlet. 8' long cord and plug set included.

AVAILABLE ACCESSORIES

- Roller kit
- Stacking collars (20 & 27 models only)
- Shelf dividers
- Overshelf kits
- Richlite and composite cutting boards

OPTIONAL UPGRADES

- LED lighting (glass door refrigerators)
- Stainless steel interior
- Door locks
- Left hand hinge door(s) (excludes UCR34Y)
- Left hinge door(s) & 3" casters packed
- Door thermometer

Item No. _____
Quantity _____

**SHALLOW DEPTH
UNDERCOUNTER
REFRIGERATORS
AND FREEZERS
FOOD PREPARATION SERIES**

**MODELS:
UCR20Y
UCF20
UCR27Y
UCF27
UCR34Y**



UCR / UCF20



UCR UCF27



UCR34

ELECTRICAL CONNECTION

Units pre-wired at factory and include 8' long cord and plug set.



115/60/1
NEMA-5-15P



Available From:

Model Specified _____	Store# _____
Location _____	Quantity _____



BEVERAGE-AIR

Shallow Depth Undercounter Refrigerators/Freezers
Models: UCR20Y, UCF20, UCR27Y, UCF27, UCR34Y

MODEL	UCR20Y	UCF20	UCR27Y	UCF27	UCR34Y
EXTERNAL DIMENSIONAL DATA					
Length Overall (inches)	20"	20"	27"	27"	34"
Length Overall (mm)	508	508	686	686	864
Depth Overall (inches) - Less handle	22"	22"	27 3/4"	27 3/4"	23 5/8"
Depth Overall (mm) - Less handle	559	559	705	705	600
Height Overall—on 6" legs (inches)	31 1/8"	31 1/8"	34 1/2"	34 1/2"	31"
Height Overall—on 6" legs (mm)	791	791	876	876	787
Depth with Door Open 90 °	40 1/2"	40 1/2"	53 1/4"	53 1/4"	38"
Clear Door Opening (inches)	15 3/4" x 18 3/16"	15 3/4" x 18 3/16"	22 1/2" x 21 3/8"	22 1/2" x 21 3/8"	13/ 1/8" x 18"
Number of doors	1	1	1	1	2
INTERNAL DIMENSIONAL DATA					
NET Capacity (cubic ft.)	2.7	2.7	6.2	6.2	5.5
NET Capacity (Liters)	77	77	176	176	156
Internal Length Overall (inches)	16"	16"	23"	23"	29 3/8"
Internal Length Overall (mm)	406	406	584	584	746
Internal Depth Overall (inches)	13"	13"	18"	18"	17"
Internal Depth Overall (mm)	330	330	457	457	432
Internal Height Overall (inches)	19"	19"	23"	23"	19"
Internal Height Overall (mm)	483	483	584	584	483
Number of shelves	2	2	2	2	4
ELECTRICAL DATA					
Full Load Amperes 115/60/1	3.0	5.3	4.0	6.0	4.0
ENERGY CONSUMPTION (KWH)	2.73	6.18	2.79	N/A	3.12
REFRIGERATION DATA					
Horsepower	1/6	1/4	1/6	1/4	1/5
WEIGHT DATA					
Gross Weight (Crated lbs)	119	130	157	162	165
Gross Weight (Crated kg)	54	59	71	74	75

PLAN VIEWS

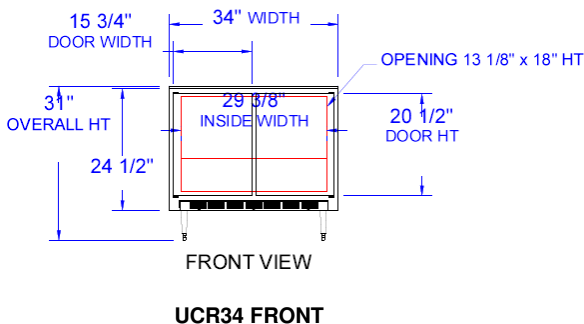
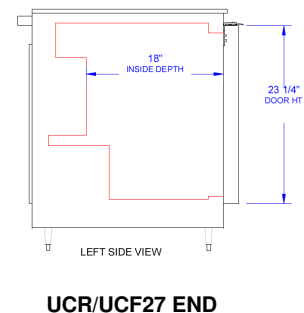
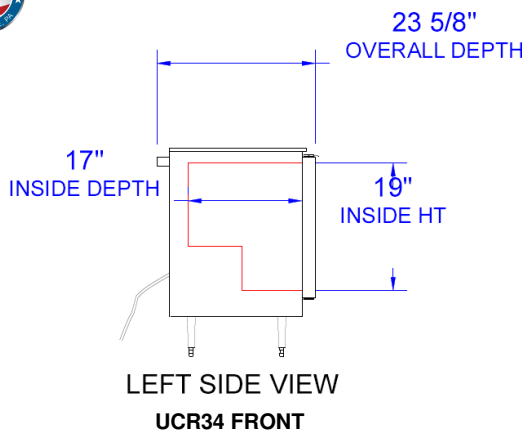
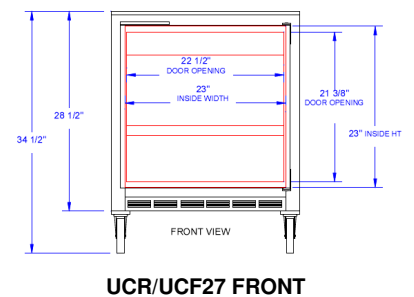
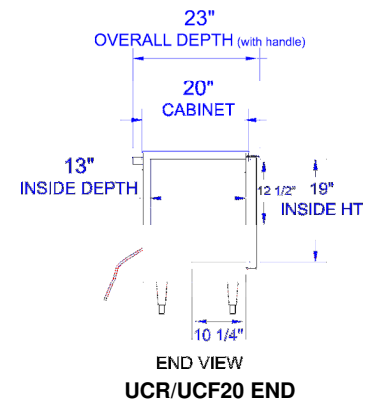
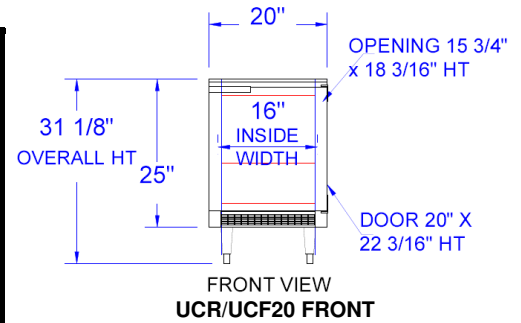

BEVERAGE-AIR® CORPORATION

3779 Champion Blvd. • Winston-Salem, NC 27105 USA • (336) 245-6400 • Fax (336) 245-6453 • (888) 845-9800 • www.beverage-air.com

Specifications are subject to change without prior notice. 08/12