



# BEVERAGE-AIR

3779 Champion Blvd., Winston-Salem, NC 27105  
1-888-845-9800 Fax# 1-336-245-6453  
<http://www.Beverage-Air.com>

## Commercial Refrigeration Equipment General Specification

**3 Year Parts/Labor Warranty**  
**Additional 2 Year Compressor Warranty**

### WORKTOP COOK STAND REFRIGERATOR

Beverage-Air's cook stand refrigerators are designed to accommodate countertop cooking equipment and feature a full marine drip-guard to prevent spills from dripping over the edge. WTRCS112 Series models are available in 2 top configurations (112" Width, 120" Width) to provide the flexibility in your workspace. Refrigerated drawers provide ample food product storage. Working height of 26 3/4" on heavy-duty six-inch (6") casters.

### CABINET CONSTRUCTION

Heavy-duty construction with stainless steel on top, front, sides, rear and drip guard top. Interior of cabinet is constructed of corrosion-resistant stainless steel. Drawers are equipped with heavy-duty workflow handle. Cabinet integrity is reinforced by use of structural columns. Cabinets are insulated with foamed-in-place polyurethane insulation of 2" thickness for added strength and maximum energy efficiency. Cabinet back and bottom are constructed of galvanized steel. Interior cabinet is made of corrosion resistant stainless steel.

Exterior solar digital thermometer with battery backup is standard.

### DRAWER CONSTRUCTION

Drawer frames are constructed of heavy duty stainless steel and are supported on stainless steel telescoping drawer slides with three stainless steel roller bearing wheels for maximum support of stored food product. Upper pull-out drawers accommodate two 6" deep 12" x 20" pans of combinations of 1/6 size pans or larger. Lower pull-out drawers accommodate two 4" deep 12" x 20" pans or combinations of 1/6 size pans or larger. Heavy duty pan divider supports are supplied. Foodservice pans are not included. A snap in type vinyl magnetic gasket is attached to each drawer for positive seal.

### REFRIGERATION

Self-contained refrigeration system utilizes R134a refrigerant metered by a capillary tube system. Automatic (hot gas) condensate evaporation is provided. Interior forced air system, with high humidity evaporator coils, provide the ideal environment for food preservation. Removable front thermometer panel and grille allows for easy access to complete lift-out refrigeration system.

Item No. \_\_\_\_\_  
Quantity \_\_\_\_\_

## WORKTOP COOK STAND REFRIGERATORS 6 DRAWER EQUIPMENT BASE WTRCS112 SERIES

MODELS:  
WTRCS112-1  
WTRCS112-1-120



WTRCS112-1



WTRCS112-1-120

### ELECTRICAL CONNECTION

Units pre-wired at factory and include 8' long cord and plug



\*Note: Not all markings may apply to all model variations.

Available From:

|                              |                       |
|------------------------------|-----------------------|
| <b>Model Specified</b> _____ | <b>Store#</b> _____   |
| <b>Location</b> _____        | <b>Quantity</b> _____ |



## PLAN VIEWS

### Work Top Refrigerator, Cook Stand Model Series Models: WTRCS112-1, WTRCS112-1-120

| MODEL                            | WTRCS112-1       | WTRCS112-1-120   |
|----------------------------------|------------------|------------------|
| <b>EXTERNAL DIMENSIONAL DATA</b> |                  |                  |
| Length Overall (inches)          | 112"             | 120"             |
| Length Overall (mm)              | 2845             | 3048             |
| Depth Overall (inches)           | 32"              | 32"              |
| Depth Overall (mm)               | 813              | 813              |
| Height Overall— (inches)         | 26 3/4"          | 26 3/4"          |
| Height Overall— (mm)             | 680              | 680              |
| Number of drawers                | 6                | 6                |
| Depth with Drawer Open 90 °      | 57 1/4"          | 57 1/4"          |
| Upper Drawer Pans                | 4—12" x 20" x 6" | 4—12" x 20" x 6" |
| Lower Drawer Pans                | 4—12" x 20" x 4" | 4—12" x 20" x 4" |
| Top Load Rating (lbs)            | 1000             | 1000             |
| Top Load Rating (kg)             | 454              | 454              |
| <b>INTERNAL DIMENSIONAL DATA</b> |                  |                  |
| NET Capacity (cubic ft.)         | 24.5             | 24.5             |
| NET Capacity (Liters)            | 694              | 694              |
| <b>ELECTRICAL DATA</b>           |                  |                  |
| Full Load Amperes 115/60/1       | 7.3              | 7.3              |
| <b>REFRIGERATION DATA</b>        |                  |                  |
| Horsepower                       | 1/4              | 1/4              |
| <b>WEIGHT DATA</b>               |                  |                  |
| Gross Weight (Crated lbs)        | 720              | 720              |
| Gross Weight (Crated kg)         | 327              | 327              |

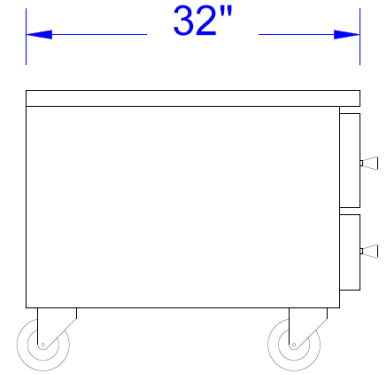

END VIEW

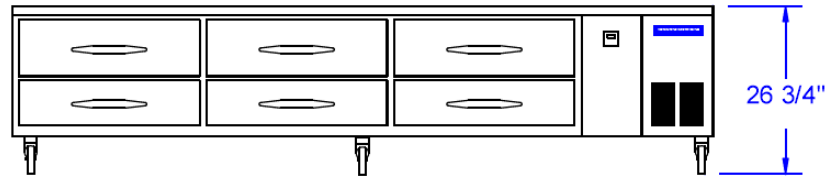

FRONT VIEW



**Note:** Not all markings may apply to all model variations.

\*N/A:: Not available at time of printing.

**WTRCS112-1  
TOP VIEW**

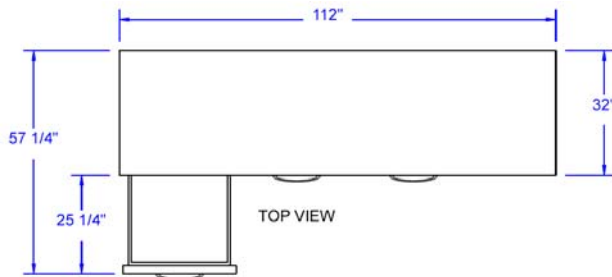

**WTRCS112-1-120  
TOP VIEW**

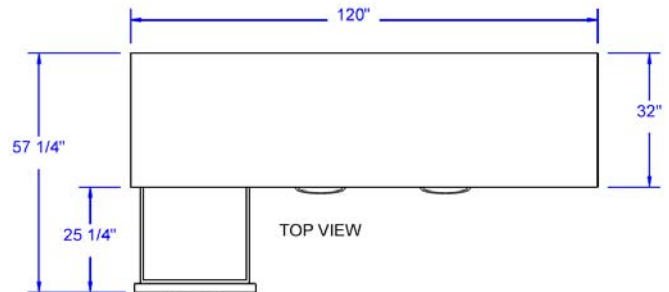

## BEVERAGE-AIR® CORPORATION

3779 Champion Blvd. • Winston-Salem, NC 27105 USA • (336) 245-6400 • Fax (336) 245-6453 • (888) 845-9800 • www.beverage-air.com

Specifications are subject to change without prior notice. 06/13