



342 N. Co. Rd. 400 East
Valparaiso, IN 46383
219-464-8818 • Fax 219-462-7985
www.heatwagon.com

Installation and Maintenance Manual

Please retain this manual for future reference.

1200DF

***Make-Up Air
Construction
Heater***



For your safety: Do not use this heater in a space where gasoline or other liquids having flammable vapors are stored.

Heat Wagon Model I200DF Make-Up Air Construction Heater

GENERAL HAZARD WARNING:

Failure to comply with the precautions and instructions provided with this heater, can result in death, serious bodily injury and property loss or damage from hazards of fire, explosion, burn, asphyxiation, carbon monoxide poisoning, and / or electrical shock.

Only persons who can understand and follow the instructions should use or service this heater.

If you need assistance or heater information such as an instructions manual, label, etc. contact **Heat Wagon**.

WARNING:

Fire, burn, inhalation, and explosion hazard. Keep solid combustibles, such as building materials, paper, or cardboard, a safe distance away from the heater as recommended by the instructions. Never use the heater in spaces which do or may contain volatile or airborne combustibles, or products such as gasoline, solvents, paint thinner, dust particles or unknown chemicals.

WARNING:

Not for home or recreational vehicle use.

FOR YOUR SAFETY:

The use and storage of gasoline or other flammable vapors and liquids in open containers in the vicinity of this appliance is hazardous.

This heater is designed and approved for use as a construction heater in accordance with standard ANSI Z83.7 • CGA 2.14.
CHECK WITH YOUR LOCAL FIRE SAFETY AUTHORITY IF YOU HAVE QUESTIONS ABOUT APPLICATIONS.
Heater is not intended for use in pest remediation.



Made in the USA

HAZARD SUMMARY

HAZARD IDENTIFICATION

Warnings and Cautions appear at appropriate sections throughout this manual. Read these carefully.

⚠️ WARNING: Indicates a potentially hazardous situation which could result in death or serious injury.

⚠️ CAUTION: Indicates a potentially hazardous situation which may result in minor or moderate injury. It may also be used to alert against unsafe practices.

CAUTION: Indicates a situation that may result in accidents with equipment or property damage only.

The following safety precautions apply to the operation and maintenance of the equipment described by this technical manual.

⚠️ WARNING:

Any unauthorized modification of this equipment shall void warranty.

⚠️ WARNING:

Operation, service, and repair of this equipment could result in exposure to electrical, mechanical or other potential safety hazards and should only be performed by qualified personnel. Use extreme caution and observe safety regulations at all times.

⚠️ WARNING:

Recirculation of room air is not permitted. Lack of proper ventilation air will lead to improper combustion. Improper combustion can lead to carbon monoxide poisoning leading to serious injury or death. Symptoms of carbon monoxide poisoning can include headaches, dizziness and difficulty breathing.

⚠️ WARNING:

All factory provided lifting lugs must be used when lifting any unit. Failure to comply with this safety precaution could result in property damage, serious injury or death.

Accessories

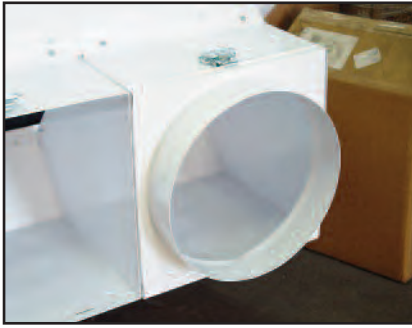

DUCT ADAPTER
#AR6953003

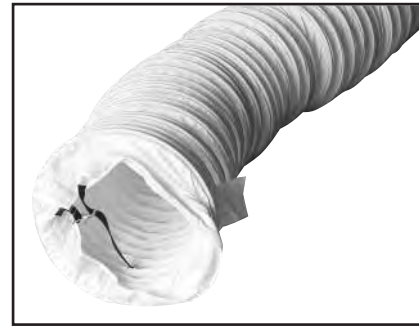

DUCTING
#WD1225
12" Diameter, 25' Long

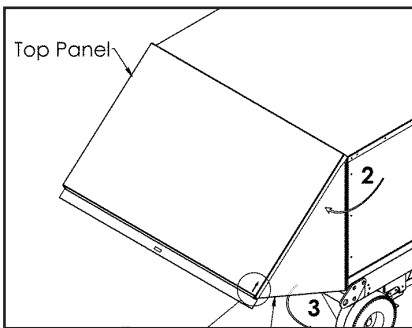

RAIN HOOD
#0306947
see diagram page 9



GAS HOSE
#7525 - 3/4" x 25'
#7550 - 3/4" x 50'
#1050 - 1" x 50'
#12525 - 1-1/4" x 25'

Installation and Maintenance Manual

Model I200DF

Make-Up Air Construction Heater

Table of Contents:

	Page
Specifications	6
Installation	7
Set Up & Operating Instructions	8
Hose Sizing	10
Wiring Diagrams	14
Parts Breakdown	18
Preventive Maintenance	19
Trouble Shooting	24
Accessories	30

WARRANTY

All new Heat Wagon and Sure Flame heaters and fans are guaranteed against defective materials and workmanship for one (1) year from invoice date.

Warranty repairs may be made only by an authorized, trained and certified Heat Wagon dealer. Warranty repairs by other entities will not be considered. Warranty claims must include model number and serial number.

LIMITATIONS

Warrant claims for service parts (wear parts) such as spark plugs, igniters, flame rods will not be allowed. Diagnostic parts such as voltage meters and pressure gauges are not warrantable.

Evidence of improper fuel usage, fuel pressures outside of manufacturer's specification, poor fuel quality, and improper electric power, misapplication or evidence of abuse may be cause for rejection of warranty claims.

Travel time, mileage and shipping charges will not be allowed. Minor adjustments of heaters are dealers' responsibility. Defective parts must be tagged and held for possible return to the factory for 60 days from date of repair. The factory will provide a return goods authorization, (RGA) for defective parts to be returned.

No warranty will be allowed for parts not purchased from Heat Wagon.



342 N. Co. Rd. 400 East • Valparaiso, IN 46383
219-464-8818 • 888-432-8924 • Fax 800-255-7985

www.heatwagon.com

SAFETY & CAUTION

- Instructions given in this manual and the applicable regulations of the local authorities must be followed.
- The unit may be operated only by those persons who have been instructed in its proper use.
- The unit is to be installed and operated in such a way as to ensure the safety of employees and surroundings.
- Never cover the unit's air openings.
- Always ensure adequate fresh air supply to the unit.
- Never stand in front of the discharge end of the heater.
- Keep a minimum clearance of 10 feet from the fuel source. Storing and use of liquid fuel must comply with the regulations and instructions given by the local authorities.
- Unit's emitted noise level at the range of 3 feet: 85dB
- Do not introduce foreign objects into the unit.
- Do not expose the unit to direct water jets.
- All electric cables outside the unit are to be protected against damage.
- Always disconnect the unit from power supply and turn off the gas supply when maintenance or service is being performed.
- **IF NOT OPERATED WITHIN GUIDELINES OF THESE OPERATING INSTRUCTIONS, MANUFACTURER WILL NOT BE HELD RESPONSIBLE AND WARRANTY WILL BECOME VOID.**

SPECIFICATIONS

Model No. 1200DF

Fuels:	Vapor Propane or Natural Gas	
Capacity:	1,200,000 BTU/HR*	
Blower:	4,000-6,000 CFM	3" SP
Electrical Rating:	240 Volts, 27.6 Amps	
Fuel Consumption:	NG-1200 CFH / Propane-13.2 GPH	
Remote Thermostat:	On/Off, RSS 40°-80°F, EDL 160°-210°F	
Max. Discharge Temp.:	210°F @ 0°F Ambient	
Duct Size:	12" Dia., 300 ft. max (straight), temp rating 275°F min.	
Weight (approximate):	1,000 lbs.	

Gas Supply:	Inlet Pressure	
	Max W.C.	Min W.C.
Vapor Propane	10 psi	5 psi
Natural Gas	10 psi	20" W.C.

This heater is designed for outdoor use only. It is intended for use in providing portable, temporary heat to buildings under construction, alteration or repair. Adequate ventilation must be provided while heater is operating. Combustible solids, such as building materials, paper or cardboard must be kept a minimum of 6 inches from the sides and top of the heaters, 0 inches from the bottom. Never use this heater in spaces which do or may contain volatile or airborne combustibles, or products such as gasoline, solvents, paint thinner, dust particles or unknown chemicals.

Adequate building relief shall be provided so as to not over pressurize the building when this heater is operating at its rated capacity. It should be noted that this can be accomplished by taking into account, through standard engineering methods, the structure's designed infiltration rate, by providing properly sized relief openings, or by interlocking a powered exhaust system, or by a combination of these methods.

IMPORTANT:

If in doubt regarding heater operation, contact Heat Wagon Customer Service Group at 219-464-8818 or by email at techservice@heatwagon.com.

These instructions must be retained for future reference.

SYSTEM DESCRIPTION

The CS-Series Heater, with high temperature rise Blow-Thru® Technology, includes a control system that is designed to electronically modulate the gas flow using an amplifier, discharge temperature sensor, and heat adjustment dial. The discharge temperature sensor, which is mounted in the heater's discharge air stream, transmits a resistance signal back to the amplifier that corresponds to the discharge temperature. The amplifier creates a voltage output to drive an electronic proportioning gas valve to maintain the pre-selected temperature that is set on the heat adjustment dial.

The CS-Series Heater is provided with a variable frequency drive (VFD) to allow for variable air volume between 4000 and 6000 CFM. The VFD air volume control is located in the operator interface panel. The VFD also limits the fan motor inrush current, allowing the heater to be powered by generator.

CONTROL MODES:

VENTILATION MODE

In this mode, the fan may be used for ventilation without heat. Airflow may be adjusted to the desired level using the Air Volume Control dial (4000 to 6000 CFM). When using ducting, ensure that bends are kept to a minimum.

LOCAL EDL MODE

The EDL (electronic discharge control) temperature control system utilizes a discharge temperature sensor, which is factory installed on the unit's discharge. This permits the adjustment of the discharge air temperature (160 F to 210 F) from the control panel. In this mode, manual control of the blower is available. (see page 12)

LOCAL EDL PLUS MODE

Same control as LOCAL EDL MODE, but with addition of remote thermostat (RSTAT),

Unit will shut off when set point is reached on remote thermostat. In this mode, manual control of the blower is available. (see page 12)

EDSM MODE

The EDSM (electronic discharge w/ space modulation) mode has several features.

It permits the adjustment of the discharge air temperature from the control panel. With the addition of the remote space sensor (RSS) located in the job site structure, the heater will modulate between programmed MAX and MIN parameters (factory preset to 210 F and 40 F respectively). The RSS is field adjustable between 40 and 80 F. In this mode, manual control of the blower is available.

OPERATING INSTRUCTIONS

⚠ WARNING:

These usage instructions must be followed each time heater is put into service.

⚠ WARNING:

For safety, this heater is equipped with a manual reset high limit switch, an air-proving switch and redundant electric shut-off valves. Never operate the heater with any safety device that has been bypassed. Do not operate this heater unless all of these features are fully functional.

1. VISUAL INSPECTION AND PLACEMENT OF EQUIPMENT

- A. Check for any physical damage from shipping or installation that could render heater unsafe or inoperable.
- B. Locate heater on level ground in close proximity to the target area and engage the wagon brakes on both the wagon's rear wheels.

⚠ WARNING:

Heater must be operated only on a stable, level surface.

COMPONENT IDENTIFICATION

Unit shown with Accessory Options

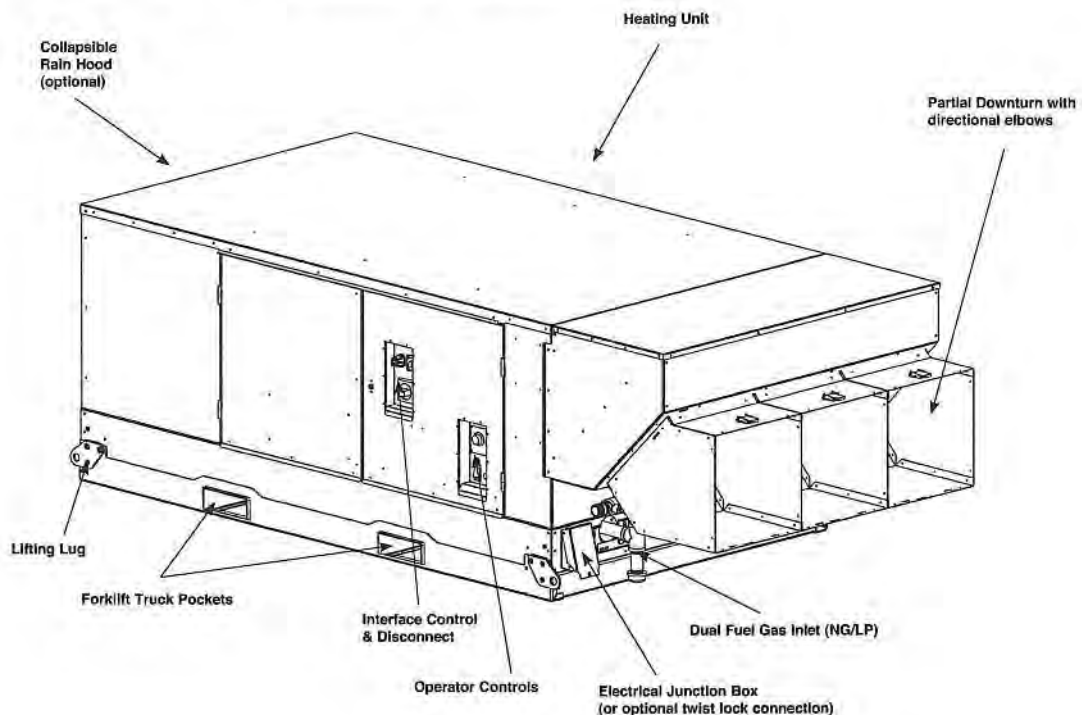

OPERATING INSTRUCTIONS

C. Open the heater's rain hood assembly per the figure below. (optional)

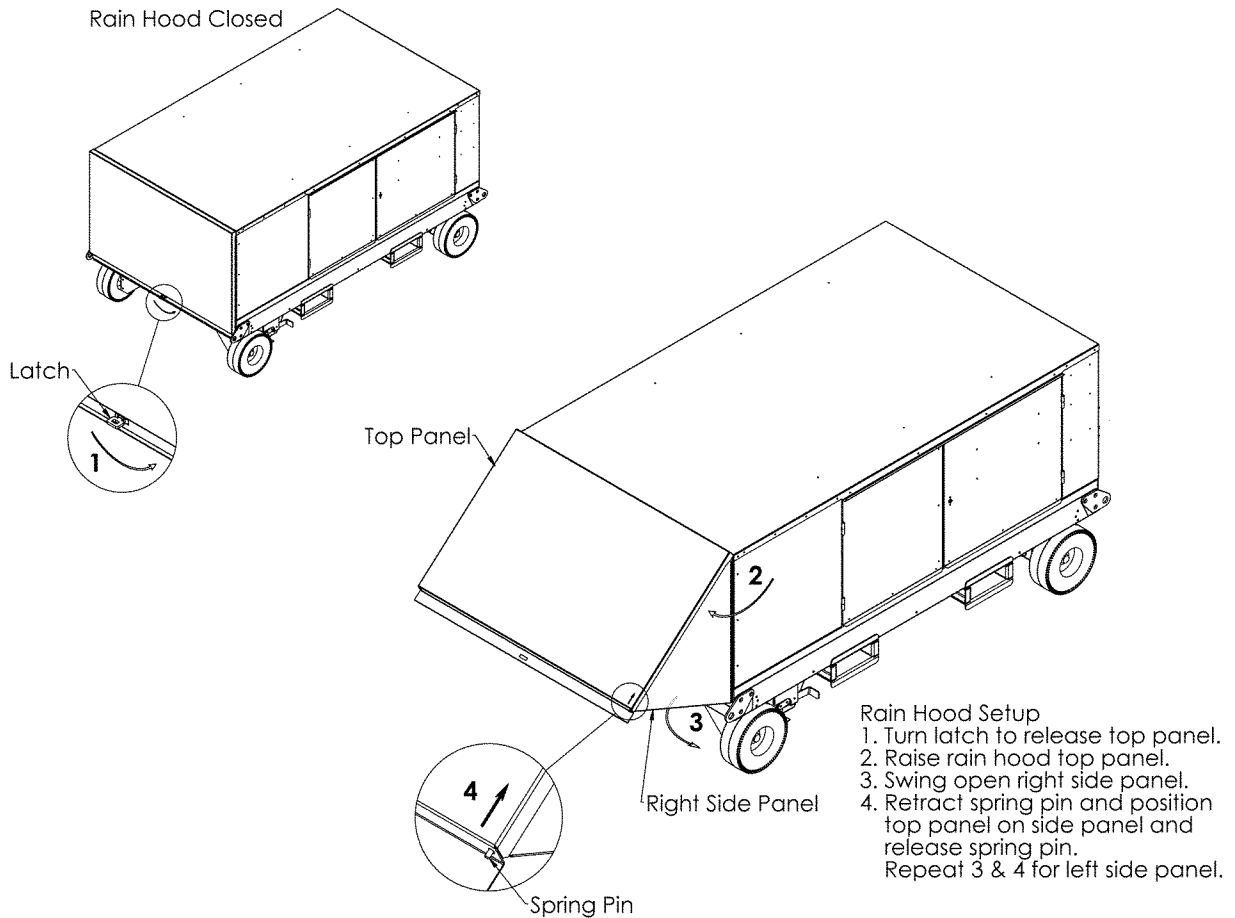

D. Install 12" diameter round flexible duct to the heater's discharge diffuser as required, closing off any unused openings.

E. Check for loose components (belts, plugs, screws, blower wheel lugs, etc.).

__2. GAS PIPING INSTALLATION

⚠️ WARNING:

Verify the gas supply pressure complies with the heater nameplate.

A. Ensure both manual shut-off valves on the heater's external gas train are closed. Verify the unions in the gas piping are tight. One is located at the burner and the other is just external to the heater housing.

IMPORTANT:

Steps B through E apply to a heater operating on liquid propane (LP) gas. If the heater is to be connected to natural gas (NG), the installation shall conform with local codes or, in the absence of local codes, with the National Fuel Gas Code ANSI Z223.1/NFPA 54 and the Natural Gas and Propane Installation Code, CSA B149.1. For heaters operated on NG proceed to step D.

B. Installation must conform with local codes or, in their absence, with the Standard for the Storage and Handling of Liquefied Petroleum Gases, ANSI/NFPA 58 and the Natural Gas and Propane Installation Code, CSA B149.1.

⚠ WARNING:

The heater must be located at least 10 feet from any propane gas container. The heater's discharge air shall not be directed toward any propane gas container within 20 feet.

Fuel Sizing Charts

**VAPOR PROPANE QUICK
REFERENCE HOSE
CHART**

Hose Length in Feet	BTU 1.5 Million	
	1/2PSI	10PSI
10	1-1/4	3/4
25	1-1/4	3/4
35	1-1/4	3/4
50	1-1/4	3/4
75	-	3/4
100	-	3/4
125	-	3/4
150	-	1-1/4
175	-	1-1/4
200	-	1-1/4
225	-	1-1/4

**NATURAL GAS QUICK
REFERENCE HOSE
CHART**

Hose Length in Feet	BTU 1.5 Million			
	<1PSI	1PSI	2PSI	5PSI
10	2	1-1/4	3/4	3/4
25	2	1-1/4	3/4	3/4
35	2	1-1/4	3/4	3/4
50	2	1-1/4	1-1/4	3/4
75	2-1/2	1-1/2	1-1/4	3/4
100	2-1/2	1-1/2	1-1/4	1-1/4
125	2-1/2	1-1/2	1-1/4	1-1/4
150	2-1/2	2	1-1/4	1-1/4

VAPORIZATION RATES IN BTUH @ 0 DEG. F							
TANK SIZE	NUMBER OF TANKS MANIFOLDED	PERCENTAGE OF TANK FILLED					
		10%	20%	30%	40%	50%	60%
500	1	198,135	264,180	308,212	352,240	396,270	440,300
	2	435,897	581,196	687,066	774,928	871,794	968,660
	3	758,857	1,011,809	1,180,451	1,349,079	1,517,714	1,686,349
1000	1	354,240	472,320	551,040	629,760	708,480	787,200
	2	779,328	1,039,104	1,212,288	1,385,472	1,558,656	1,731,840
	3	1,356,739	1,808,985	2,110,483	2,411,980	2,713,478	3,014,976

NOTE: USE FOLLOWING MULTIPLIERS FOR OTHER AIR TEMPERATURES

- For -10° F multiply x 0.50
- For + 10°F multiply x 1.5
- For +20°F multiply x 2.0
- For +40°F multiply x 3.0
- For +50°F multiply x 3.5
- For +60°F multiply x 4.0



⚠ WARNING:

The hose assembly must be visually inspected prior to each use of the heater. If it is evident there is excessive abrasion or wear, or the hose is cut, it must be replaced prior to the heater being put into operation.

C. Connect the gas hose assembly provided with the heater between the LP cylinder(s) and the gas train.

D. Open gas supply valve(s). Please note minimum and maximum inlet pressure to heater on page 6.

E. Check all connections for gas leaks using approved gas leak detectors. Gas leak testing is performed as follows:

⚠ WARNING:

- **Do not use open flame (matches, torches, candles, etc.) in checking for gas leaks.**
- **Use only approved leak detectors.**
- **Failure to follow this warning can lead to fires or explosions.**
- **Fires or explosions can lead to property damage, personal injury or death.**

- Check all pipe connections, hose connections, fittings and adapters upstream of the gas supply inlet connection with approved gas leak detectors.
- In the event a gas leak is detected, check the components involved for cleanliness and proper application of pipe compound before further tightening.
- Furthermore tighten the gas connections as necessary to stop the leak.
- After all connections are checked and all leaks are stopped, proceed to next step.

3. ELECTRICAL INSTALLATION

⚠ WARNING:

Before attempting electrical installation, review the following instructions and wiring and connection diagrams to make sure you have a thorough understanding of what is required.

A. Check the heater nameplate to determine the voltage and amperage requirements.

B. Install the supply wiring, adequate Branch Circuit Protection, and electric grounding in compliance with the National Electric Code ANSI/NFPA 70 or the Canadian Electrical Code C22.1, Part I.

⚠ CAUTION:

Ensure that the supply voltage to the heater is within +/- 10% of the nameplate voltage.

Minimum Voltage; 208V at heater

4. HEATER OPERATION

- A. Ensure that the rain hood is locked open and discharge accessories are securely attached. Make sure the caster brakes are locked. Open gas train access panels.
- B. With main disconnect in OFF position, open electrical panel door, confirm blower switch in “LOCAL” position (“ON” position) and mode switch in EDL position (Fig. C).

⚠ WARNING:

When disconnect switch is activated with gas train enclosure open, live power is present. Only experienced technicians with knowledge and respect for live power should proceed beyond this point.

- C. Close door and turn disconnect to ON position. Adjust airflow to desired level using the Air Volume Control dial. When using ducting, ensure that bends are kept to a minimum (Fig. B).
- D. The VFD will energize and blower will slowly increase rpm until operational speed is achieved. Allow the blower to operate for 30 seconds to purge heater cabinet and any attached ductwork.
- E. Open internal and external manual shut-off valves located on the heaters gas train. Heater defaults to liquid propane (LP) operation when energized. For natural gas operation the “Natural Gas Select Switch” must be pressed when the unit is energized and the Burner Switch is in the “ON” position (Fig. B).
- F. Turn the Burner on-off switch (located on the Control Door) to the “on” position. The ignition sequence will begin and the burner “on” light will energize (Fig. B).

IMPORTANT:

It is normal for air to be trapped in gas hose on new installations. The heater may require more than one trial for ignition before air is finally purged from line and ignition takes place. Should the burner “ON” light de-energize, cycle the burner override switch.

- G. With the burner operating, spray the complete gas train and supply piping with leak detector solution, checking all pipe connections and plugs.

⚠ WARNING:

All gas leaks detected must be repaired before heater is placed into service.

- H. Close and secure gas train access panels. Adjust temperature to desired level using the Temperature Selector Dial.

- I. Adjust the temperature to the desired level using the Temperature Select Dial. Adjust the blower speed to the desired airflow level using the Air Volume Control.
- J. Leave Blower Switch in the “LOCAL” (“ON” position) mode.
- K. **In order to switch between modes, turn burner off and turn unit disconnect to OFF position**

5. EDL Plus Mode

- A. With disconnect off, open electrical panel and switch fan to remote position (Fig. C).
- B. Close electrical panel door and connect remote thermostat (RSTAT) (Fig. A). Adjust thermostat to desired temperature.
- C. Repeat steps 4 - C, D, E, F.
- D. Heater will shut down when RSTAT set point is met.

6. EDSM Control Mode

- A. The unit is shipped factory default for the EDL control system. To utilize the EDSM control system the EDSM Mode Select switch must be engaged and blower switch in “Local Mode” (“ON” position).
- B. When utilizing the EDSM control system, connect the Remote Space Stat. To the RSS Interface using the Remote Space Sensor Male Connector.
- C. Select the desired room temperature using the “Up” and “Down” arrows on the Remote Space Stat.
- D. Close and secure the Access and Control Panel Doors.
- E. To restart unit for normal operation, turn unit’s Disconnect Switch to the “ON” position.
- F. Turn the Burner “On-Off” switch to the “ON” position.
- G. If applicable, press the natural Gas Select switch.



Fig. A

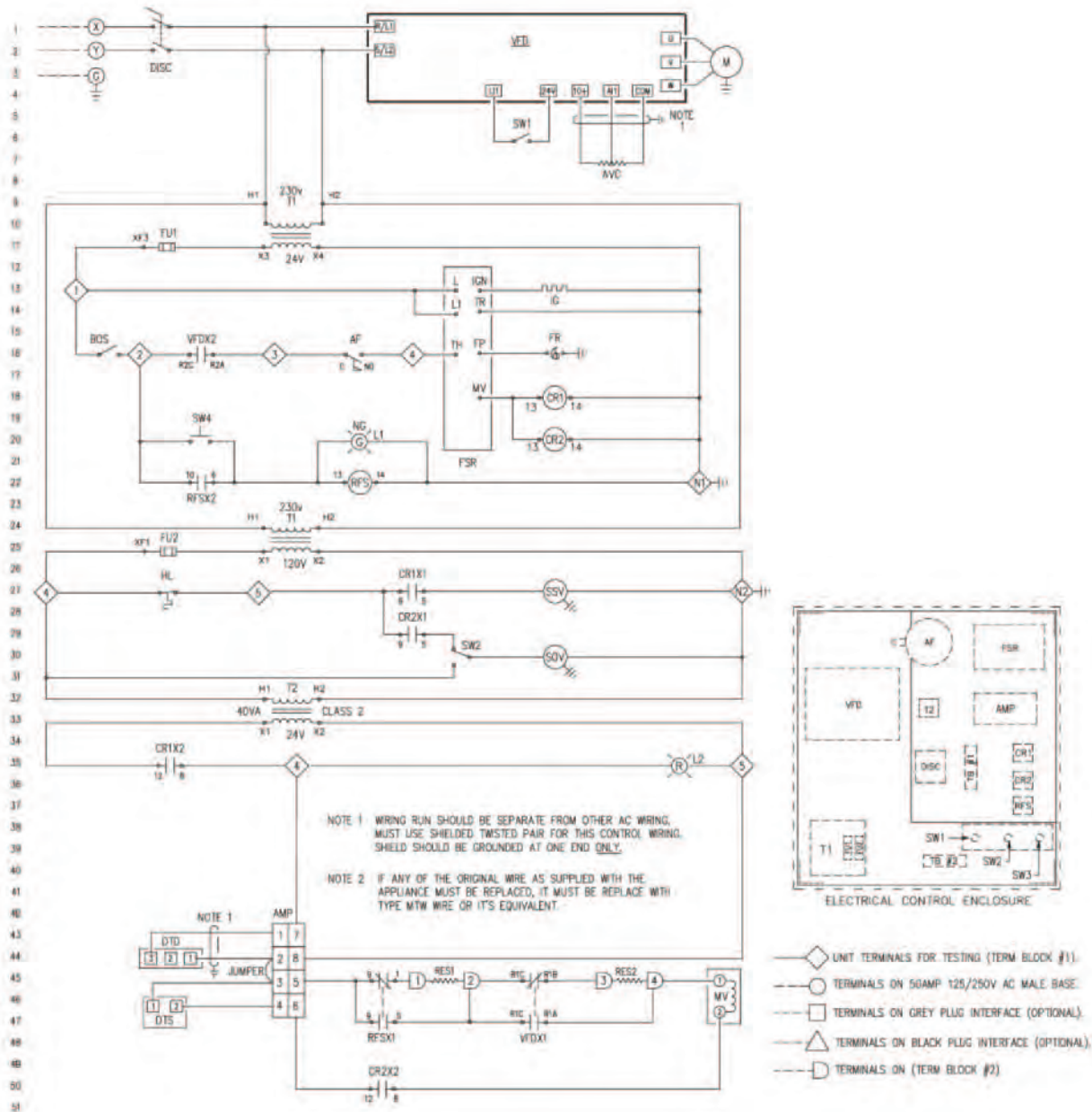

Fig. B



Fig. C

WIRING & CONNECTION DIAGRAM - EDL CONTROLS



SYMBOL	DESCRIPTION
AF	Air Flow Switch
AMP	Amplifier Solid State
AVC	Air Volume Control
BOS	Burner ON-OFF Switch
CR1	Control Relay - Gas Valve On
CR2	Control Relay - Gas Valve On
DISC	Service Disconnect Non - Fused
DTD	Discharge Temperature Dial
DTS	Discharge Temperature Sensor

SYMBOL	DESCRIPTION
FR	Flame Rod
FSR	Flame Safeguard Relay (HSI)
FU1	Fuse 24 Volt Control
FU2	Fuse 120 Volt Control
HL	High Limit
IG	Ignitor
L1	Light - Burner
M	Motor
MV	Modulating Valve

SYMBOL	DESCRIPTION
RFS	Relay - Fuel Switch
SOV	Shut-off Valve - Gas
SSV	Safety shut-off Valve - Gas
SW1	Blower Override Switch
SW2	Switch - SOV Leak Test
SW4	Switch - NG Mode Selector
T1	Dual Output Transformer
T2	Class 2 Transformer (24 Volt)
VFD	Variable Frequency Drive

WIRING & CONNECTION DIAGRAM - EDSM CONTROLS

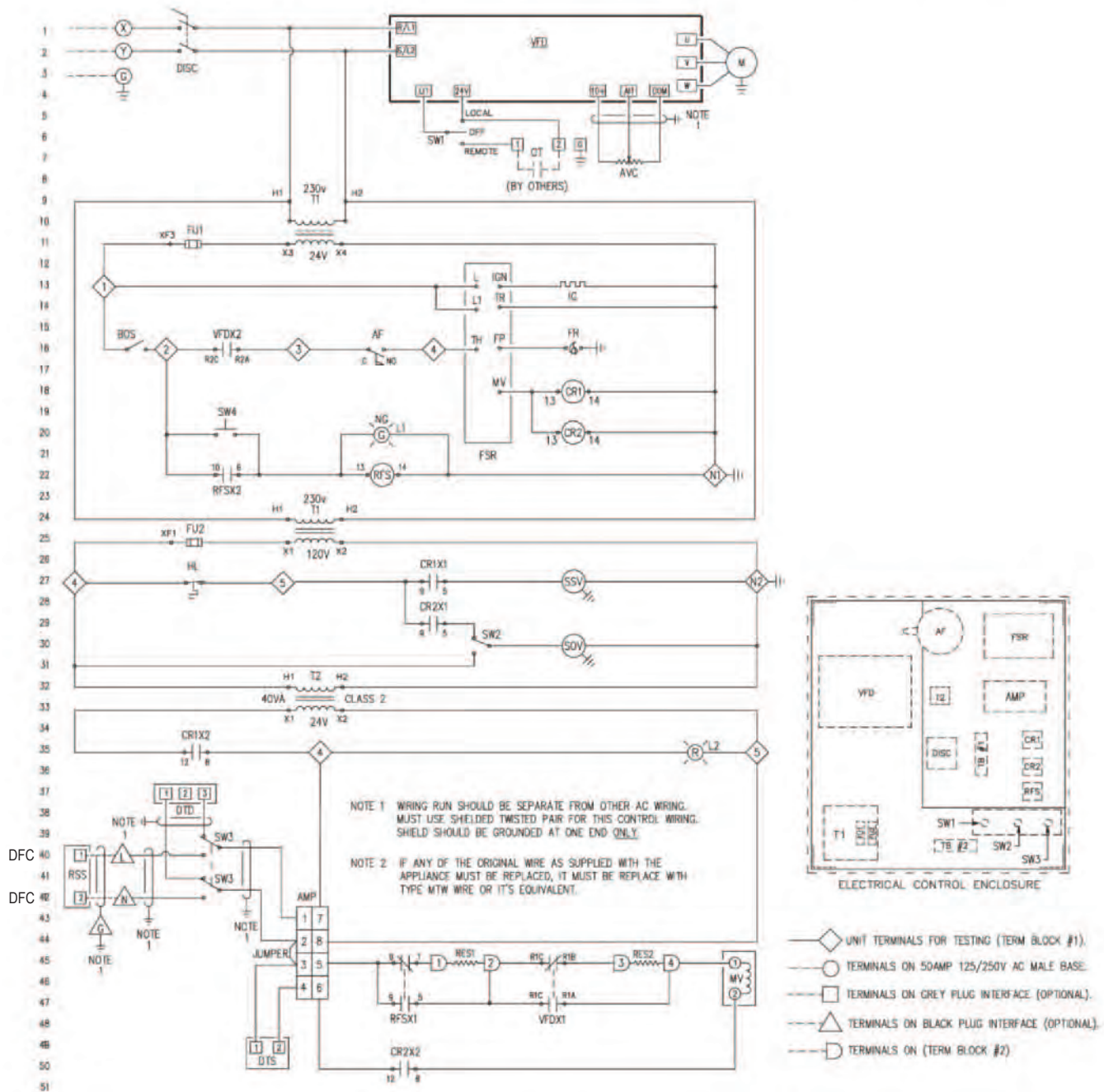

SYMBOL	DESCRIPTION
AF	Air Flow Switch
AMP	Amplifier Solid State
AVC	Air Volume Control
BOS	Burner ON-OFF Switch
CR1	Control Relay - Gas Valve On
CR2	Control Relay - Gas Valve On
DISC	Service Disconnect Non - Fused
DTD	Discharge Temperature Dial
DTS	Discharge Temperature Sensor
FR	Flame Rod

SYMBOL	DESCRIPTION
FSR	Flame Safeguard Relay (HSI)
FU1	Fuse 24 Volt Control
FU2	Fuse 120 Volt Control
HL	High Limit
IG	Ignitor
L1	Light - Burner
M	Motor
MV	Modulating Valve
RFS	Relay - Fuel Switch
SOV	Shut-off Valve - Gas

SYMBOL	DESCRIPTION
SSV	Safety shut-off Valve - Gas
SW1	Blower Override Switch
SW2	Switch - SOV Leak Test
SW3	Switch - Operating Mode Selector
SW4	Switch - NG Mode Selector
T1	Dual Output Transformer
T2	Class 2 Transformer (24 Volt)
VFD	Variable Frequency Drive
RSS	Remote Space Sensor

SUPPLY PRESSURE REQUIREMENTS

GAS SUPPLY PRESSURE REQUIREMENTS TABLE	NATURAL GAS	LIQUID PROPANE
Minimum gas supply pressure for maximum input adjustment	20" wc (50 mbar)	5" PSI (.35 bar)
Minimum gas supply pressure to maintain flame signal	1.0" wc (2.5 mbar)	1.0" wc (2.5 mbar)
Maximum gas supply pressure	10" PSI (.69 bar)	10" PSI (.69 bar)

GAS TRAIN COMPONENTS

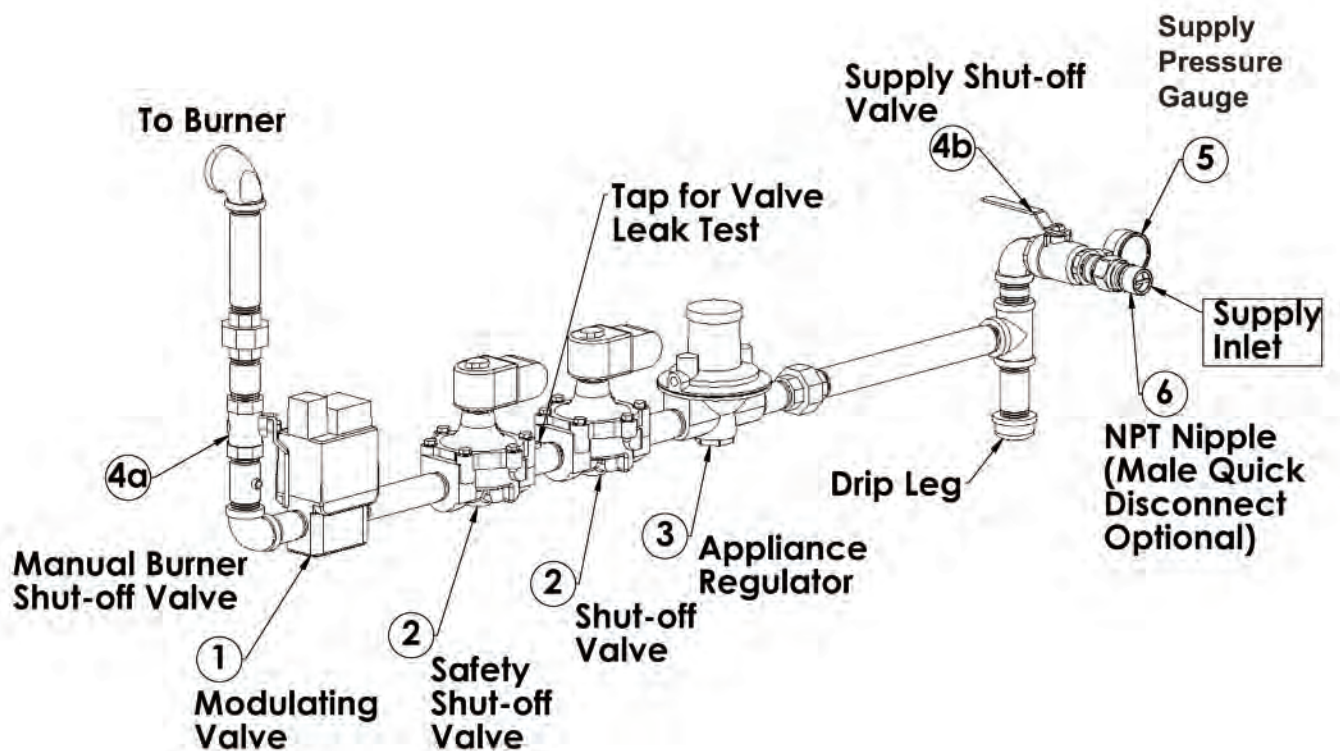

ELECTRICAL COMPONENTS

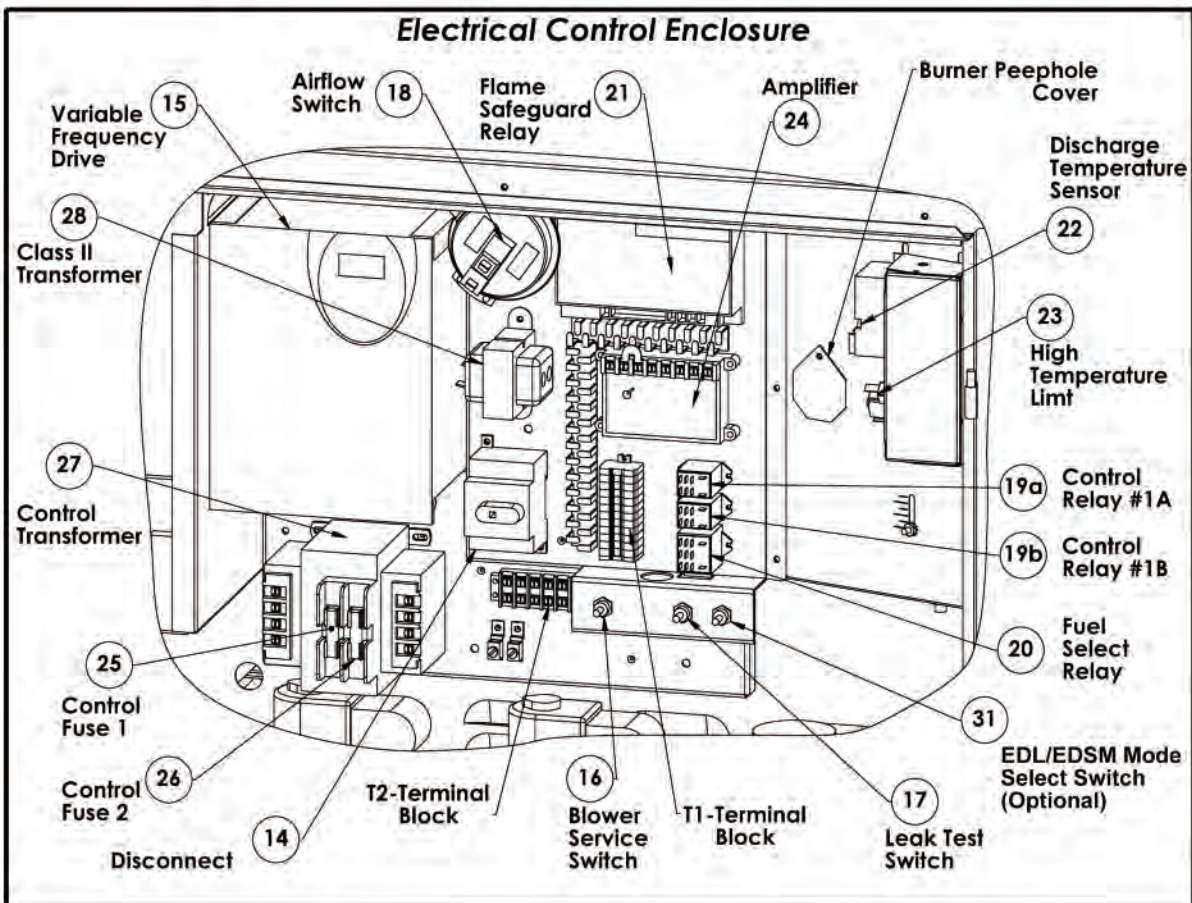
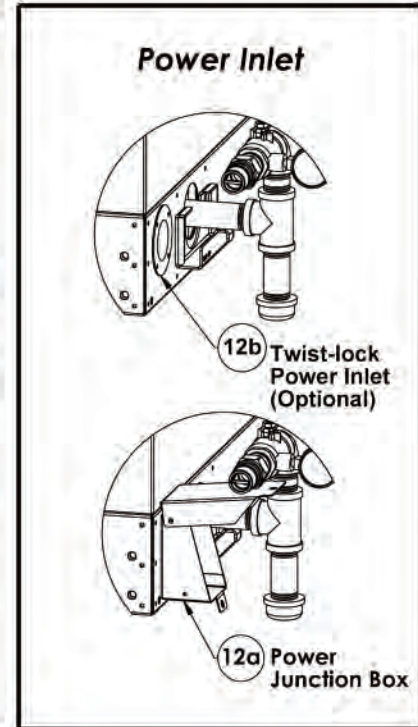
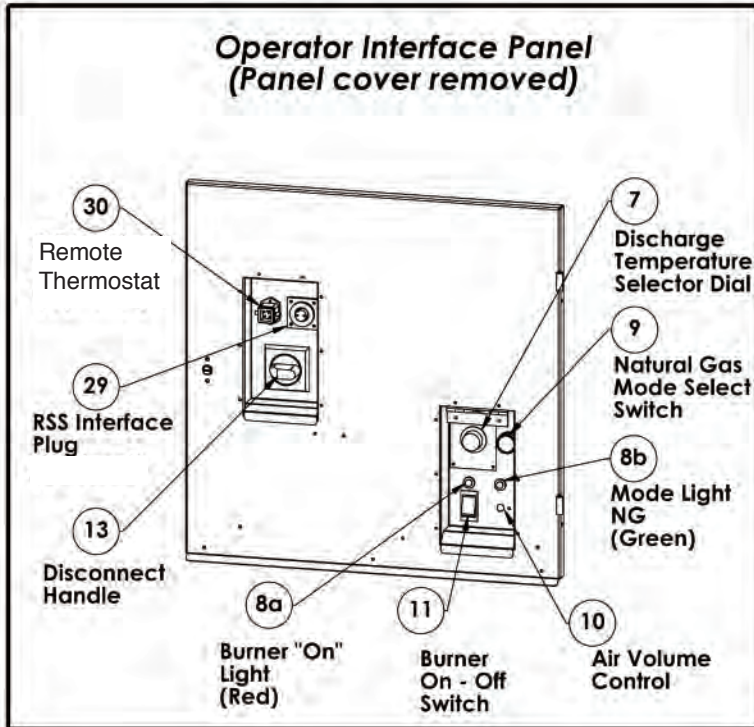

PARTS LIST

Component Parts List			
Item	Location (Manual Page)	Description	Part Number
1	Gas Train	Valve - Gas Modulating M611	24-033
2	Gas Train	Valve - Gas Shut Off	21-118
3	Gas Train	Regulator - Appliance lbs. to inches	24-008
4a.	Gas Train	Manual Burner Shut-Off Valve	24-020
4b.	Gas Train	Manual Supply Gas Shut-Off Valve	24-115
5	Gas Train	Gauge - Supply Pressure	23-633
6	Gas Train	Supply Gas Quick Disconnect - 1" NPT	44-123
7	Operator Interface	DFTD (Temperature Selection Dial)	23-016
8a	Operator Interface	Burner On Light LP (Red)	22-602
8b	Operator Interface	Burner On Light NG (Green)	22-601
9	Operator Interface	Switch - Natural Gas Select	22-295
10	Operator Interface	Air Volume Controller	22-104
11	Operator Interface	Burner On - Off Switch	22-107
12a	Operator Interface	Power Junction Box	6940-939
12b	Operator Interface	Power Inlet, Twist Lock (Optional)	22-127
13	Operator Interface	Disconnect Handle	22-276
14	Control Enclosure	Disconnect 60A Non-Fused	22-272
15	Control Enclosure	VFD 5HP 230v 1ph	23-905
16	Control Enclosure	Switch - Blower On - Off	22-040
17	Control Enclosure	Switch - SOV Leak Test (Momentary)	22-762
18	Control Enclosure	Airflow Switch	21-125
19a	Control Enclosure	Control Relay - Gas Valve ON	22-761
19b	Control Enclosure	Control Relay - Gas Valve ON	22-761
20	Control Enclosure	Control Relay - Fuel Select	22-295
21	Control Enclosure	Flame Safeguard Relay	21-142
22	Control Enclosure	Discharge Temperature Sensor	23-220
23	Control Enclosure	Switch - High Temp Limit - 250°F	23-168
24	Control Enclosure	Amplifier - Solid State (DFC-1)	23-217
25	Control Enclosure	Control Fuse 6.25 amp	22-019
26	Control Enclosure	Control Fuse 1.6 amp	22-078
27	Control Enclosure	Transformer Dual Output 350 va	22-111
28	Control Enclosure	Transformer Class 2 40va	22-678
29	Optional Control	R S S Female Connection	22-529
30	Optional Control	Optional Thermostat Connection	22-526
31	Optional Control	Optional Control Mode Selection Switch	22-138
-	Not Shown	R S S Male Connection	22-528
-	Not Shown	R S S	23-107
-	Not Shown	Gas Quick Disconnect - Female 1" NPT	44-125
-	Not Shown	Flame Rod	21-062
-	Not Shown	Igniter - 24v Hot Surface	21-097
-	Not Shown	Remote Thermostat (w/50' cord)	THIDF
-	Not Shown	Caster	HW4080

Contact the Heat Wagon Customer Service Group at (219) 464-8818 or by email at techservice@heatwagon.com.

MAINTENANCE INSTRUCTIONS

⚠️ WARNING:

The heater area must be kept clear and free from combustible materials, gasoline, and other flammable vapors and liquids.
The flow of combustion and ventilation air must not be obstructed.

⚠️ WARNING:

Place the heater disconnect switch in the "OFF" position when performing service or maintenance functions. Heater surfaces are hot for a period of time after the heater has been shut down. Allow heater to cool before performing service, maintenance or cleaning. Failure to follow this warning will result in burns causing injury.

IMPORTANT:

The heater should be inspected before each use, and at least annually by a qualified service technician.

BLOWER BEARING LUBRICATION

The CS1200 model heaters require lubrication on intervals of 3 to 6 months. Use Shell "Alvania #2" Exxon "Unirox N2" Mobil "532", Mobil "Mobilux #2", Texaco "Multifak #2", Texaco "Premium RB" lubricants.

MOTOR BEARING LUBRICATION

Motors are pre-greased normally with Shell "Dolium R". Equivalent greases which are compatible with the motor furnished grease are Chevron "SRI No. 2" and Texaco "Premium RB".

HOURS OF SERVICE PER YEAR	SUGGESTED RELUBE INTERVAL NEMA FRAME SIZE
Motor Frame Size	42 to 215T
5000 Hours	5 years
Continous Normal Application	2 years
Seasonal Service Motor Is Idle For 6 Months Or More	1 year (Beginning of Season)
Continous High Ambients, Dirty Or Moist Locations, Or High Vibration	6 months

BELT TENSIONING

Using a Browning Belt Tension Checker and a straight edge, attain proper tension according to the following table:

Model	Motor HP	Belt(s)		Nominal Deflection	Belt Tension	
		Qty	Type		New	Used
CS1200	5	2	BX	0.25 (1/4)"	3 - 5 lbs	2.5 - 4 lbs

Periodic belt adjustments may be required. Indications of loose belts include barking or squealing when the blower starts.

ELECTRIC SHUT-OFF VALVE LEAK CHECK

WARNING:

The heater shall be periodically evaluated, at least annually, for the seal tightness of the electric shut-off valves.

The heater is equipped with a leak test facility to assist in checking these seals. A momentary switch and a gas port for measuring pressure between valves are provided as the leak test hardware. The procedures for the electric shut-off valve leak check are as follows.

- A. Connect a 0 to 10 inches water column (" WC) manometer to the 1/8" NPT tapped fitting on the manual shut-off valve located just prior to the burner. Verify the manometer is properly zeroed.
- B. To check the tightness of second electric shut-off valve (SSV), close the manual burner shut-off valve, hold the momentary leak test switch in the closed position, and wait 30 seconds to read the manometer. If reading is greater than 0" WC, refer to the Maintenance Instruction Section for information on Gas Valve Cleaning for the second electric shut-off valve (SSV) and retest. If reading is 0" WC, remove manometer, install pipe plug and open manual burner shut-off valve.
- C. To check the gas tightness of the first electric shut-off valve (SOV) in the gas train, connect the manometer to the leak test port between the valves and wait 30 seconds to read the manometer. If reading is greater than 0" WC, refer to the Maintenance Instruction Section for information on Gas Valve Cleaning for the first electric shut-off valve and retest. If reading is 0" WC, remove manometer and install pipe plug.

WARNING:

Do not wash the interior of the heater. Use only compressed air, a soft brush or dry cloth to clean the interior of the heater and its components.

BLOWER CLEANING

Blower wheel should be examined for accumulation of dust on the concave side of the blades. These surfaces must be kept clean. Dirt accumulation will result in significant air flow reduction and/or possible imbalance of blower wheel.

CAUTION:

Prolonged imbalance can result in catastrophic failure of the blower wheel and other related components.

BURNER CLEANING

The Cambridge Engineering burner is for the most part self-cleaning. However, if the application is extremely dirty or subject to heavy insect infestation, it may become necessary to periodically clean the burner. Remove and clean the burner in accordance with the following recommended procedures.

- A. Turn the heater disconnect switch to the "OFF" position. Close the manual burner shut-off valve.
- B. Loosen union in the gas train.

CAUTION:

Igniter is made of silicon carbide material and should be handled with care to avoid breakage.

- C. Disconnect ignition cable from burner and then remove flame rod.
- D. Examine flame rod ceramic for cracks and replace if necessary. Clean dirt/grime build-up from insulator.
- E. Remove fasteners that secure burner to the housing. Burner will then be free to slide out.

⚠ CAUTION:

Be sure to take necessary safety precautions (such as wearing eye protection, etc.) before attempting this step.

- F. Clean burner by back-flushing using high pressure air (40-80 psi). Continue back-flushing until dust and debris has been completely expelled from burner. Wipe all burner surfaces with a cloth to remove any foreign matter.

⚠ CAUTION:

Cleaning burner and burner orifice with anything other than compressed air may drastically affect heater performance.

- G. Perform Discharge Air Temperature Sampling Tube cleaning at this time.
- H. Reassemble burner using above steps in reverse order.

DISCHARGE AIR TEMPERATURE SAMPLING TUBE CLEANING

With the Burner out of the unit, clean the Discharge Air Temperature Sampling Tube located inside unit. The Sampling Tube is located inside the discharge duct beyond the stainless steel burner extension(s). Clean Sampling Tube using high pressure air (40-80 psi) until all debris is completely removed from Tube.

ELECTRIC SHUT-OFF VALVE CLEANING

All solenoid valves should be cleaned periodically. The time between cleanings will vary depending on the medium and service conditions. In general, if the voltage to the coil is correct, sluggish valve operation, excessive noise, or leakage will indicate that cleaning is required.

⚠ WARNING:

In the extreme case, faulty valve operation will occur and the valve may fail to open or fully close.

IMPORTANT:

It is not necessary to remove the valve from the pipeline for cleaning.

⚠ WARNING:

To prevent the possibility of severe personal injury or property damage, turn off electrical power, close the upstream manual gas valve, depressurize valve, extinguish all open flames and avoid any type of sparking or ignition. Vent hazardous or combustible fumes to a safe area before servicing the valve.

ASCO Gas Valves: Series 8214

Disassemble valve and clean all parts as follows:

IMPORTANT: If parts are worn or damaged, install a complete ASCO Rebuild Kit.

- A. Remove solenoid enclosure.
- B. Remove bonnet screws, valve bonnet, bonnet gasket, core/diaphragm sub-assembly and body gasket.
- C. All parts are now accessible to clean or replace.
- D. Lubricate bonnet gasket and body gasket with a light coat of DOW CORNING ® 200 Fluid lubricant or an equivalent high-grade silicone fluid.
- E. Apply a light coat of RemGrit TFL 50 ® Dry Lubricant to: Valve seat; Valve body surface where diaphragm assembly contacts the valve body and body gasket; and internal surface of valve bonnet where diaphragm assembly contacts bonnet when valve is in the energized (open position).

IMPORTANT:

If valve has been disassembled for inspection and cleaning only and a Rebuild Kit is not being installed, lubricate the following with RemGrit TFL 50® Dry Lubricant:

- Diaphragm assembly on both sides
- Main disc at base of core/diaphragm sub-assembly.
- Pilot disc at base of core assembly.

⚠ CAUTION:

Do not distort hanger spring between core assembly and diaphragm assembly when lubricating pilot disc.

- F. Replace body gasket and core/diaphragm sub-assembly with closing spring attached. Locate bleedhole in core/diaphragm sub-assembly approximately 30° CCW from the valve inlet.
- G. Replace valve bonnet and bonnet screws (6). Torque screws in a crisscross manner to 100 ± 10 inch lbs. Replace solenoid and make electrical hookup.

⚠ WARNING:

To prevent the possibility of severe personal injury or property damage, check valve for proper operation before returning to service. Also perform a gas valve leak check and gas train leak check.

ORDERING INFORMATION FOR ASCO REBUILD KITS

Parts marked with an asterisk (*) in the exploded views are supplied in Rebuild Kits.

When ordering Rebuild Kits for ASCO valves, order the Rebuild Kit number stamped on the valve nameplate. If the number of the kit is not visible, order by indicating the number of kits required, and the Catalog Number and Serial Number of the valve(s) for which they are intended.

Disassembled View of ASCO Valve

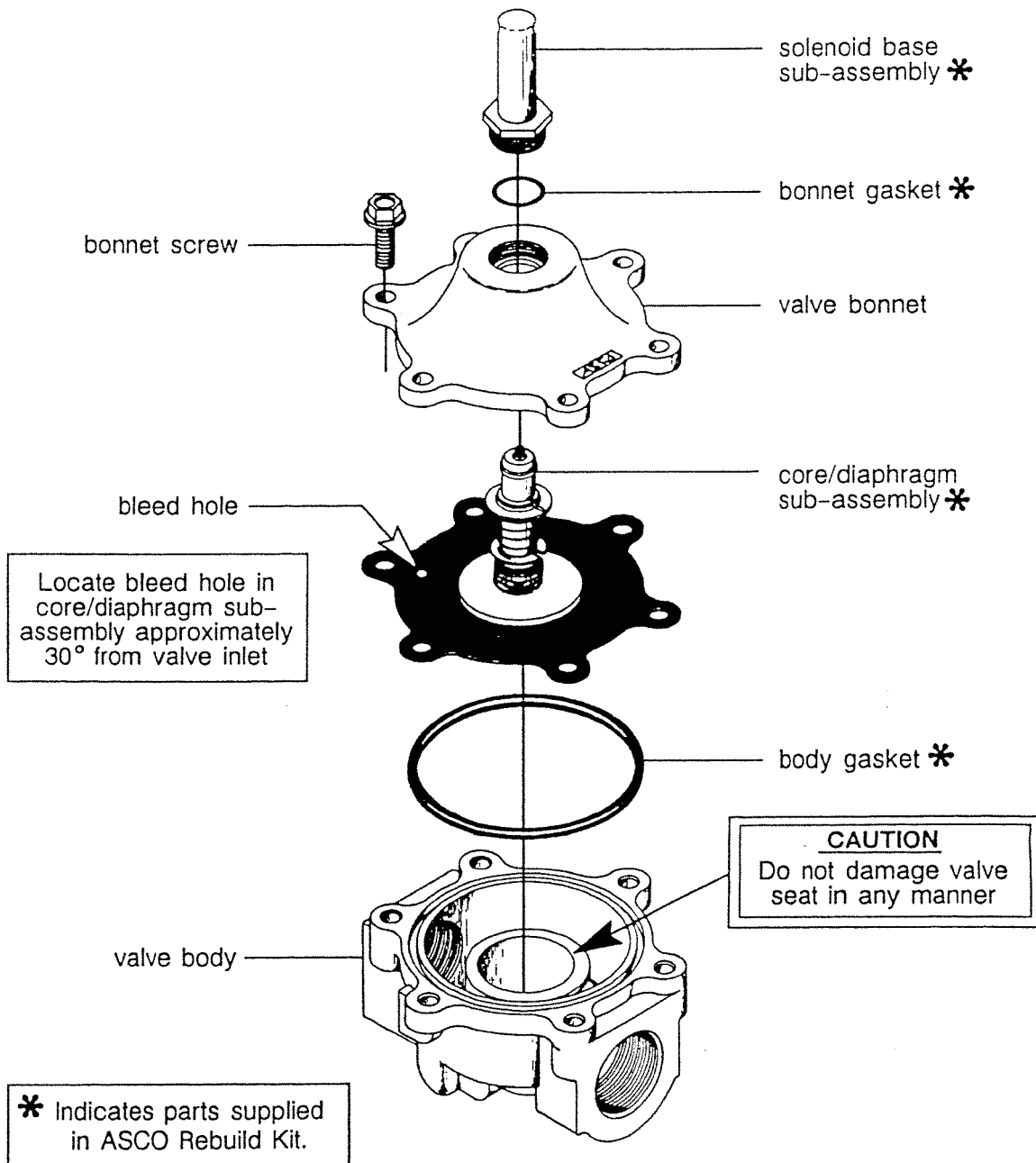

TROUBLESHOOTING GUIDE

PROBLEM	POSSIBLE CAUSE	CORRECTIVE ACTION
I. NO BLOWER OPERATION	1. Heater Disconnect a) Disconnect in "OFF" position	a) Turn disconnect "ON"
	2. Blower Override Switch a) Switch in OFF position b) Defective switch	a) Place switch in the "ON" position. b) Replace switch.
	3. Control Transformer a) No input voltage b) Blown control fuse c) Defective transformer	a) Check disconnect and supply fusing b) Replace control fuse c) Replace transformer
	4. Motor Protection a) VFD in alarm b) VFD defective	a1) Check primary power source a2) Cycle VFD with disconnect a3) Reduce motor speed using air volume control b) Replace VFD
	5. Motor a) No input voltage b) Improper voltage c) Defective motor	a) Check primary power source b) Consult factory c) Replace motor
	6. Blower Damage a) Defective or locked bearings b) Check for physical damage	a) Replace bearings. b) Replace or repair blower.
	7. Belts a) Belt slipping b) Belt broken or missing	a) Tighten belts. b) Replace belts.
	8. Thermostat (EDL Plus Mode)	a. Set point below ambient
II. BLOWER RUNS; NO HEAT; FLAME SAFETY RELAY DOESN'T LOCK OUT	1. Burner Override Switch a) Switch in "OFF" position b) Defective Switch	a) Place switch in "ON" position. b) Replace Switch
	2. Air Flow Switch a) Blower running backwards b) Belts slipping c) Blocked intake or discharge d) Clogged airflow tubing or pickup ports e) Excessive static pressure f) Switch defective	a) Reverse any two of the three motor leads to the VFD b) Tighten and/or replace belts c) Find and remove obstruction d) Clean or replace tubing or pickup ports e1) Increase motor speed using air volume control dial e2) Reduce static pressure f) Replace switch

TROUBLESHOOTING GUIDE

PROBLEM	POSSIBLE CAUSE	CORRECTIVE ACTION
	3. Flame Safeguard Relay (FSR) a) No input voltage b) Defective FSR	a) Check wiring b) Replace FSR
III. BLOWER RUNS; NO HEAT; FLAME SAFETY RELAY LOCKS OUT	1. Igniter a) No current (open igniter) b) No voltage	During trial for ignition: a) Check igniter current (1.6 AMPS) b) Check FSR output to igniter (24 VAC)
	2. High Limit a) High limit tripped	a) See Problem Number VI
	3. Electric Shut-off Valve a) No input voltage b) Gas valve does not open c) Defective electric shut-off valve	a1) Check FSR output to R1 relay during ignition trial a2) Check electric shut-off valve circuit and wiring b1) Compare supply voltage to nameplate voltage b2) Clean and/or replace electric shut-off valve parts c) Replace valve
	4. Modulating Valve a) Minimum fire set too low	a) Adjust minimum fire on modulating valve
	5. Regulator a) Clogged vent orifice b) No supply pressure c) Improper manifold pressure d) Defective regulator	a) Clean or replace orifice b) Check manual shut-off valve and piping c1) For NG - adjust appliance regulator per nameplate c2) For LP - adjust high pressure regulator per nameplate d) Replace regulator
	6. Burner a) Burner defective	a) Replace burner
IV. BLOWER RUNS; BURNER LIGHTS; FLAME SAFETY RELAY LOCKS OUT	1. Low Flame Current (μA) a) Dirt build-up on flame rod ceramic insulator b) Minimum fire set too low c) Flame rod defective	a) Clean dirt deposit from ceramic surface and install protective boot b) Adjust minimum fire on modulating valve c) Replace flame rod

TROUBLESHOOTING GUIDE

PROBLEM	POSSIBLE CAUSE	CORRECTIVE ACTION
	d) Burner defective	d) Replace burner
	2. No Flame Current a) Ground connection open b) Flame rod wire termination oxidized c) Flame rod defective	a) Reference T1 transformer to ground a2) Tighten loose ground screws b) Clean terminal and reinsert c) Replace flame rod
	3. Fluctuating Flame Current a) Unit over firing b) Minimum fire set too low c) Intermittent ground connection d) Loose terminal on Flame Rod e) Flame rod defective d) Burner defective	a) Check manifold pressure b) Adjust minimum fire on modulating valve c) Tighten all ground points d) Tighten jam nuts e) Replace flame rod d) Replace burner
	4. Flame Safeguard Relay a) Defective FSR	a) Replace relay
V. BLOWER RUNS; UNIT HEATS; SHORT CYCLES WITHOUT RESETTING	1. Air Flow Switch a) Blower running backwards b) Belts slipping c) Blocked intake or discharge d) Clogged airflow tubing or pickup ports e) Excessive static pressure f) Switch defective	a) Reverse any two of the three motor leads to the VFD b) Tighten and/or replace belts. c) Find and remove obstruction. d) Clean or replace tubing or pickup ports. e1) Increase motor speed using air volume control dial e2) Reduce static pressure f) Replace switch.
	2. Flame Safeguard Relay a) Defective FSR	a) Replace FSR.
VI. HIGH LIMIT TRIPPED	1. High Limit a) High limit will not reset	a) Replace high limit.
	2. Unit Overfiring a) Excessive manifold pressure	a) If NG - adjust appliance regulator per heater nameplae a2) If LP - adjust high pressure regulator per heater nameplate
	3. Airflow Reduced a) Blower running backwards	a) Reverse motor direction.

TROUBLESHOOTING GUIDE

PROBLEM	POSSIBLE CAUSE	CORRECTIVE ACTION
	<ul style="list-style-type: none"> b) Belts slipping c) Blocked intake or discharge 	<ul style="list-style-type: none"> b) Tighten and/or replace belts. c) Find and remove obstruction.
	<p>4. Temperature Control System</p> <ul style="list-style-type: none"> a) Temperature control system does not modulate 	<ul style="list-style-type: none"> a) See problem VII
<p>VII. MODULATING VALVE DOES NOT MODULATE; CONTINUOUS HIGH FIRE</p>	<p>1. Amplifier</p> <ul style="list-style-type: none"> a) Wire(s) not connected to amplifier b) Jumper not installed between terminals 2 and 3 of A1014 or AD1014 c) Amplifier defective 	<ul style="list-style-type: none"> a) Re-install wire(s) b) Re-install jumper c) Replace amplifier
	<p>2. Discharge Temperature Sensor</p> <ul style="list-style-type: none"> a) Discharge air temperature sampling tube clogged b) Open in sensor circuit c) Sensor cross-wired to amplifier 	<ul style="list-style-type: none"> a) Clean Discharge Air Temperature Sampling Tube (see page 16) b) Replace the sensor if the resistance measured at: terminals 1 and 2 on EDL sensor exceeds 15,000 Ω; terminals 1 and 3 or 2 and 3 on EDSM sensor exceeds 6,000 Ω c) Correct wiring terminations
	<p>3. RSS (EDSM only)</p> <ul style="list-style-type: none"> a) Open in sensor circuit b) Induced voltage in field wiring c) Space sensor located improperly 	<ul style="list-style-type: none"> a) Replace the sensor if the resistance of sensor circuit is more than 7,000 Ω b) Utilize shielded, twisted pair wiring c) Remote space sensor in cold draft - relocate
	<p>4. Modulating Valve</p> <ul style="list-style-type: none"> a) Foreign material holding valve open 	<ul style="list-style-type: none"> a) Replace valve
<p>VIII. MODULATING VALVE DOES NOT MODULATE; CONTINUOUS LOW FIRE</p>	<p>1. Modulating Valve</p> <ul style="list-style-type: none"> a) Valve coil is open or shorted 	<ul style="list-style-type: none"> a) Replace valve if coil resistance is less than 40 Ω or greater than 85 Ω
	<p>2. Class II Transformer</p> <ul style="list-style-type: none"> a) No voltage output to amplifier 	<ul style="list-style-type: none"> a) Replace transformer
	<p>3. Amplifier</p> <ul style="list-style-type: none"> a) No output voltage to valve 	<ul style="list-style-type: none"> a) With the wire removed from terminal 3 of amplifier, replace

TROUBLESHOOTING GUIDE

PROBLEM	POSSIBLE CAUSE	CORRECTIVE ACTION
		amplifier if the valve voltage does not exceed 18 volts DC.
	<p>4. Discharge Temperature Sensor (TS114 or TS144) a) Short in sensor circuit</p>	a) Replace the sensor if the resistance measured at: terminals 1 and 2 on EDL sensor is less than 5,000 Ω ; terminals 1 and 3 or 2 and 3 on EDSM sensor is less than 2,000 Ω
	<p>5. Space Temperature Selector (EDSM only) a) Short in sensor circuit b) Remote space sensor located improperly</p>	<p>a) Replace the sensor if the resistance measured in the sensor circuit is less than 5,000 Ω b) Sensor located in heated air stream - relocate</p>
ERRATIC OR IX. PULSATING FLAME	<p>1. High Pressure Regulator a) Defective regulator</p>	a) Replace regulator
	<p>2. Amplifier a) Hunting b) Defective Amplifier</p>	<p>a) Adjust sensitivity control dial counter-clockwise b) Replace amplifier</p>
	<p>3. Remote Space Sensor (RSS) a) Induced voltage in field wiring</p>	a) Utilize shielded, twisted pair wiring

MINIMUM FIRE ADJUSTMENT PROCEDURE

The minimum fire setting is preset at the factory at approximately 25°F rise for NG and approximately 40°F rise for LP. If an adjustment is necessary, a DC microammeter is required to monitor flame signal during the adjustment procedure to ensure the flame current remains steady and of sufficient strength to maintain burner operation for both consistent ignition at minimum fire and locking in the flame safeguard relay. Do not allow the flame signal to drop below 2.0 microamps DC.

- A. Turn the Disconnect to the “ON” position and monitor the discharge temperature.
- B. Remove the wire from terminal No. 8 on the amplifier.
- C. Turn the Burner ON-OFF Switch to the “ON” position and monitor the discharge air temperature. Subtract the temperature from Step A above from this reading to determine the temperature rise.
- D. Remove cap (A), located on the rear of the valve, exposing the minimum fire adjusting screw. Using a small flat head screw driver, turn the adjusting screw to obtain the desired minimum fire setting.
- E. Replace the cap (A)
- F. Reconnect wire to amplifier terminal No. 8.

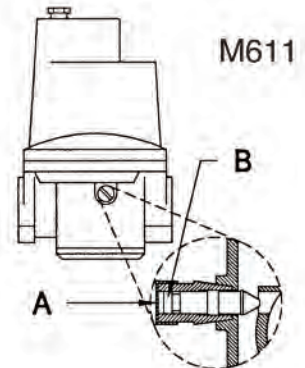

Accessories

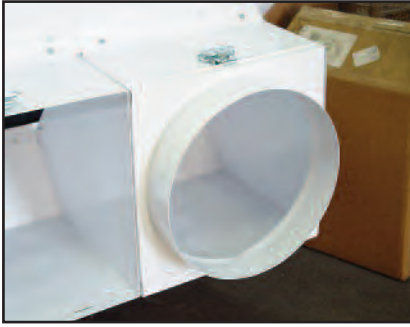

DUCT ADAPTER
#AR6953003



DUCTING
#WD1225
12" Diameter, 25' Long

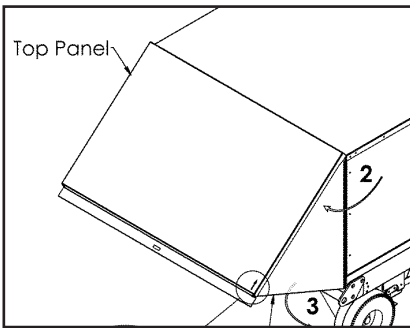

RAIN HOOD
#0306947
see diagram page 9

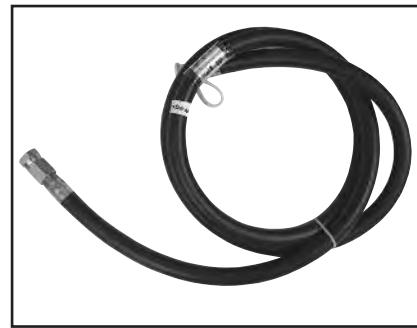

GAS HOSE
#7525 - 3/4" x 25'
#7550 - 3/4" x 50'
#1050 - 1" x 50'
#12525 - 1-1/4" x 25'



342 N. Co. Rd. 400 East

Valparaiso, IN 46383

219-464-8818 • Fax 219-462-7985

www.heatwagon.com