



342 N. Co. Rd. 400 East  
Valparaiso, IN 46383  
219-464-8818 • Fax 219-462-7985  
[www.heatwagon.com](http://www.heatwagon.com)

## Installation and Maintenance Manual

Please retain this manual for future reference.

# DF400/DF600

## Construction Heaters



For DF400 Models  
SN 27601001 and beyond

For DF600 Models  
SN 27701501 and beyond



*For your safety: Do not use this heater in a space where gasoline or other liquids having flammable vapors are stored.*

## **CONSTRUCTION HEATER GENERAL HAZARD WARNING:**

Failure to comply with the precautions and instructions provided with this heater, can result in death, serious bodily injury and property loss or damage from hazards of fire, explosion, burn, asphyxiation, carbon monoxide poisoning, and/or electrical shock.

Only persons who can understand and follow the instructions should use or service this heater.

If you need assistance or heater information such as an instruction manual, labels, etc., contact your local Heat Wagon dealer or the manufacturer.

Heater is not intended for use in pest remediation.

## **W A R N I N G**

Fire, burn, inhalation, and explosion hazard. Keep solid combustibles, such as building materials, paper or cardboard, a safe distance away from the heater as recommended by the instructions. Never use the heater in spaces which do or may contain volatile or airborne combustibles, or products such as gasoline, solvents, paint thinner, dust particles or unknown chemicals.

**Not for home or recreational vehicle use!**

# Installation and Maintenance Manual Model DF400 - DF600 Construction Heater

## Table of Contents:

	<b>Page</b>
Control Board . . . . .	4
Recommendations . . . . .	5
Operation . . . . .	5
Safety . . . . .	5
Maintenance . . . . .	5
Troubleshooting . . . . .	6-11
Sequence of Operation . . . . .	10
Specifications . . . . .	12
Wiring Diagrams . . . . .	14-15
Parts Breakdown . . . . .	16-19

## WARRANTY

All new Heat Wagon and Sure Flame heaters and fans are guaranteed against defective materials and workmanship for one (1) year from invoice date.

Warranty repairs may be made only by an authorized, trained and certified Heat Wagon dealer. Warranty repairs by other entities will not be considered. Warranty claims must include model number and serial number.

## LIMITATIONS

Warrant claims for service parts (wear parts) such as spark plugs, igniters, flame rods will not be allowed. Diagnostic parts such as voltage meters and pressure gauges are not warrantable.

Evidence of improper fuel usage, fuel pressures outside of manufacturer's specification, poor fuel quality, and improper electric power, misapplication or evidence of abuse may be cause for rejection of warranty claims.

Travel time, mileage and shipping charges will not be allowed. Minor adjustments of heaters are dealers' responsibility. Defective parts must be tagged and held for possible return to the factory for 60 days from date of repair. The factory will provide a return goods authorization, (RGA) for defective parts to be returned.

No warranty will be allowed for parts not purchased from Heat Wagon.



**342 N. Co. Rd. 400 East • Valparaiso, IN 46383**  
**219-464-8818 • 888-432-8924 • Fax 800-255-7985**  
**www.heatwagon.com**

# Control Board

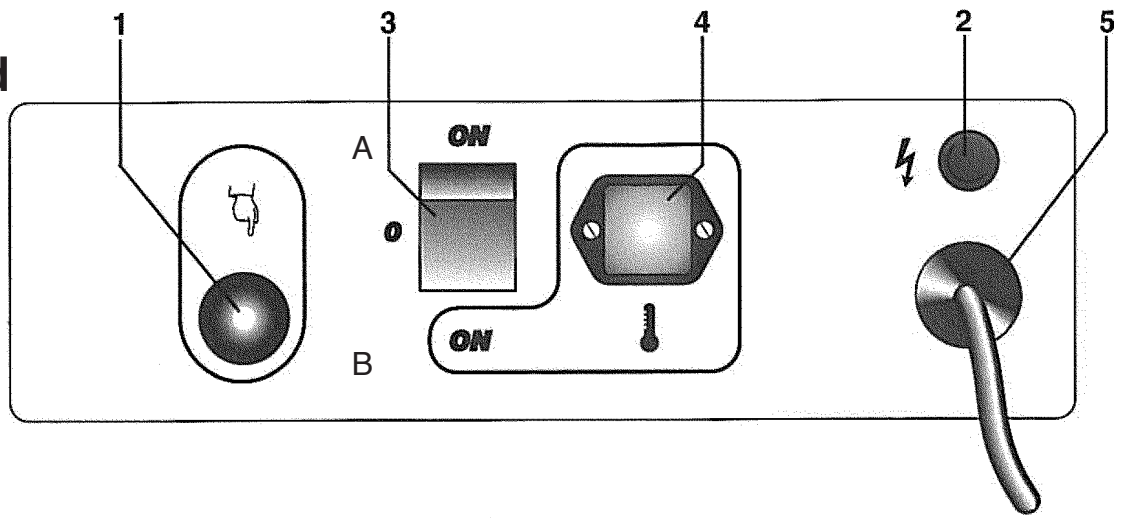

- 1 RESET BUTTON WITH CONTROL LAMP
- 2 CONTROL LAMP
- 3 MAIN SWITCH  
A-No Thermostat  
B-With Thermostat
- 4 ROOM THERMOSTAT PLUG
- 5 POWER CORD

## REGULATION OF ELECTRODES

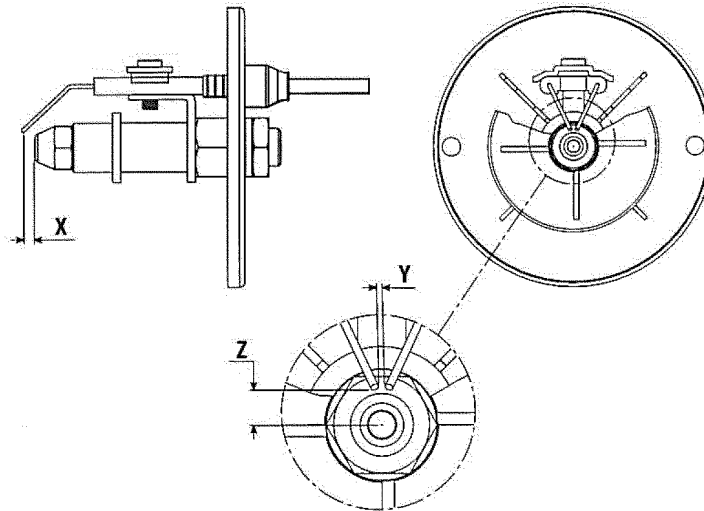

Models	X	Y	Z
DF400	2 mm	3 mm	6,5 mm
DF600	2 mm	3 mm	6,5 mm

Note: 1mm = 0.039 inch

Fuel Blend Guide	
Temperature Range	Fuel Blend
15° to 30°F	80% #2 : 20% #1
0° to 15°F	70% #2 : 30% #1
-15° to 0°F	50% #2 : 50% #1
below -15°F	30% #2 : 70% #1

#1 Kerosene  
#2 Diesel Fuel (Winter Blend)



## IMPORTANT

Before using the heater, read and understand all instructions and follow them carefully. The manufacturer is not responsible for damages to goods or persons due to improper use of units.

### GENERAL RECOMMENDATIONS

The hot air heaters run on heating oil. Those with direct combustion send hot air and the combustion products into the room.

Always follow local ordinances and codes when using this heater:

- Read and follow this owner's manual before using the heater;
- THE INSTALLATION OF THE UNIT SHALL BE IN ACCORDANCE WITH THE REGULATIONS OF THE AUTHORITIES HAVING JURISDICTION. Also, as a recommended installation practice reference should be made to the current issue of CSA B139, Installation Code for Oil Burning Equipment in Canada and NFPA 31 Standard for the Installation of Oil-Burning Equipment in the USA.
- Use only in places free of flammable vapours or high dust content;
- Never use heater in immediate proximity of flammable materials (the minimum distance must be 6 ft.)
- Make sure fire fighting equipment is readily available;
- Make sure sufficient fresh outside air is provided according to the heater requirements. Direct combustion heaters should only be used in well vented areas in order to avoid carbon monoxide poisoning;
- A rough estimate of opening required for each gallon (US) of capacity is one square foot for indirect-fired heater and three square foot at heater level, for direct-fired heaters;
- Never block air inlet (rear) or air outlet (front);
- In case of very low temperatures add kerosene to the heating oil;
- Connect the power cord to the mains and wait 15 min at least before starting heater, to allow pre-heated filter warming heating oil inside the filter;
- Before starting the heater always check free rotation of ventilator;
- Unplug heater when not in use.

### OPERATION

Before any attempt of starting the heater is made, check that your electrical supply conforms to the data on the model plate.

#### Warning



**Mains must be fitted with a circuit breaker**

**Unit plug must be linked to a main with a disconnect switch**

The heater can only work automatically when a control device, such as for example a thermostat or a timer, is connected to the heater. Connection to the heater is made by removing the socket cover (4) and inserting the thermostat plug.

To start the machine you must:

- if connected to the thermostat, turn the switch to (ON + );
- if not connected to the thermostat, turn the switch to (ON).

When unit is started for the first time or is started after the oil tank has been totally emptied, the flow of oil to the burner may be impaired by air in the circuit. In this case the control box will cut out the heater and it might be necessary to renew the starting procedure once or twice by depressing the reset button (1).

Should the heater not start, check that oil tank is full and depress reset button (1).

Should the heater still not work, please refer to chapter "OBSERVED FAULTS, CAUSES AND REMEDIES".

### STOPPING THE HEATER

Set main switch (3) on "0" position or turn thermostat or other control device on lowest setting.

The flame goes out and the fan continues to work for approx. 90 sec. cooling the combustion chamber.

### SAFETY DEVICES

The unit is fitted with an electronic flame control box. In case of malfunction this box will cut in and stop the heater, at the same time the pilot lamp in the control box reset button (1) will light up.

Heaters are also equipped with an overheat thermostat safety cut out which will stop the heater in case of overheating. This thermostat will reset automatically but you will have to depress button (1) on control box before being able to restart the heater.

**Before making any attempt to restart heater find and eliminate reason of overheating.**

### TRANSPORT



Before heater is moved it must be stopped and unplugged. Before moving the heater wait till it has totally cooled off and make sure oil tank cap is securely fixed.

### MAINTENANCE

Preventive and regular maintenance will ensure a long trouble free life to your heater.

#### Warning



**Never service heater while it is plugged in, operating or hot. Severe burns or electrical shock can occur.**

Every 50 hours of operation: disassemble filter and wash with clean oil, remove upper body parts and clean inside and ventilator with compressed air, check correct attachment of H.T. connectors to the electrodes and check H.T. cables, remove burner assembly, clean and check electrode settings, adjust according to scheme "REGULATION OF ELECTRODES". (see page 4)

### Clearances

The following minimum safety clearances from materials or objects in the surroundings of the heater must be ensured:

Sides	2.5 ft.	Air Inlet	2.5 ft.
Top	6 ft.	Air outlet	12 ft.

- Floors and ceilings must be made of fireproof materials in the room where the heater is operated.
- The air inlet and outlet must never be blocked for any reason.
- Install the heater on a flat, level floor in a steady position.
- It is forbidden to connect direct-fired heaters to air ducts.

### ⚠ WARNING

- DO NOT USE GASOLINE, NAPHTHA OR VOLATILE FUELS.
- STOP HEATER BEFORE ADDING FUELS.
- ALWAYS FILL OUTDOORS AWAY FROM OPEN FLAME
- DO NOT USE EXTERNAL FUEL SOURCE.
- DO NOT OPERATE HEATER WHERE FLAMMABLE LIQUIDS OR VAPORS MAY BE PRESENT.
- DO NOT START HEATER WHEN CHAMBER IS HOT
- DO NOT START HEATER WHEN EXCESS FUEL HAS ACCUMULATED IN THE CHAMBER.
- DO NOT PLACE COOKING UTENSILS ON TOP OF THE HEATER.
- PLUG ELECTRICAL CORD INTO A PROPERLY GROUNDED THREE-PRONG RECEPTACLE.

## OBSERVED FAULTS, CAUSES AND REMEDIES

OBSERVED FAULT	CAUSE	REMEDY
• Motor does not start, no ignition	• No electrical current	• Check mains
		• Check proper positioning and functioning of switch
		• Check fuse
	• Wrong setting of room thermostat or other control	• Check correct setting of heater control. If thermostat, make sure selected temperature is higher than room temperature
	• Thermostat or other control defective	• Replace control device
	• Electrical motor defective	• Replace electrical motor
• Motor starts, no ignition or cuts out	• Not enough or no fuel at all at burner	• Check state of motor-pump plastic coupling
		• Check fuel line system including fuel filter for possible leaks
		• Clean or replace oil nozzle
	• Airswitch failure	• Defective airswitch • Lack of air from duct restriction
	• Flame control box defective	• Replace control box
	• Photocell defective	• Clean or replace photocell • Check resistance, if zero or infinite-replace
• Motor starts, heater emits smoke	• Electric ignitor defective	• Check connection of H.T. leads to electrodes and transformer
		• Check electrodes setting (see scheme "REGULATION OF ELECTRODES")
		• Check electrodes for cleanliness
	• Replace H.T. transformer	
	• Solenoid defective	• Check electrical connection • Check thermostat LI • Clean or replace solenoid
• Heater does not stop	• Not enough combustion air	• Make sure air inlet and outlet are free
		• Check setting of combustion air flap (see page 11)
		• Clean burner disc
	• Too much combustion air	• Check setting of combustion air flap (see page 11)
	• Fuel contaminated or contains water	• Drain fuel in tank with clean fuel
		• Clean oil filter
	• Air leaks in fuel circuit	• Check the seals on the ducts and the diesel filter
• Not enough fuel at burner	• Check pump pressure (see page 11)	
	• Clean or replace fuel nozzle	
• Too much fuel at burner	• Check pump pressure (see page 11)	
	• Replace nozzle	
• Heater does not stop	• Solenoid defective	• Replace solenoid coil or complete solenoid

If heater still not working properly, please revert to nearest authorized dealer.



## **ADVANCED TROUBLESHOOTING**

### **Motor runs, no visible ignition and heater reset (red light) comes on**

#### **Causes:**

1. Fuel filter is dirty.
2. Spray nozzle clogged.
3. Air proving switch defective.
4. Air entering the fuel pump thru the inlet line.
5. Safety thermostat defective or tripped.
6. Fuel pump is defective/or broken pump coupling.
7. Solenoid valve is defective.
8. Control board is defective.
9. Defective transformer.

***\*NOTE: Top cover shell of heater needs to be attached during troubleshooting (will affect operation of airswitch and photocell).***

#### **Solutions:**

1. Fuel filter dirty. Check the external and internal fuel filters and clean or replace as necessary. Most fuel pumps contain an internal fuel filter located where the inlet line enters the fuel pump.
2. Spray nozzle clogged. Remove and inspect the spray nozzle. Clean or replace as needed. Do not clean the nozzle orifice with anything metal as this may enlarge the orifice.
3. Air proving switch is defective. Try to start the heater without ducting. Oil heaters have an air proving switch wired between the control board and the solenoid valve. (Review Sequence of Operation, page 10). The air proving switch is normally open and requires air from the turning fan blade to close the switch and send power to the solenoid valve. Set a multi-meter to measure voltage. With the fan blade turning, check for voltage coming out of the air proving switch to the solenoid valve. If no voltage is read, next check for voltage at the control board terminals out to the air proving switch. If voltage at the control board is read, the air proving switch is defective. If no voltage is read at the board, the control board is defective.
4. Air entering the fuel pump thru the fuel inlet line. If air enters the pump it will lose its prime and will not maintain adequate pump pressure. First make sure all fittings, including the fuel filter on the inlet line are tight. If you still suspect air is entering the pump, start eliminating portions of the inlet line until the air leak is found. Start this process at the fuel tank end of the inlet line. It may be necessary to draw fuel from a small container rather than the fuel tank.
5. Safety thermostat defective or tripped. Also called overheat switch. Some oil heaters have a safety thermostat wired between the control board and the solenoid valve. If the heater becomes too hot this normally closed switch will open and interrupt power to the solenoid valve. Use a multi-meter set to measure ohms. Place the multi-meter probes on the two male terminals of the safety thermostat. If the multi-meter shows infinity (no continuity) the safety thermostat is defective. If the switch opens up before the heater becomes hot, the safety thermostat is defective.
6. Fuel pump is defective. The output pressure of the fuel pump can be checked by placing a high pressure fuel gauge into the gauge port of the fuel pump. Use a gauge with enough capacity to measure the high pressure your particular heater can produce. Use the adjustment on the pump to set the pump pressure to the manufacturer's specification. If you do not have a fuel gauge, you may slightly loosen the pump's output line connection and place a rag there. Run the heater briefly and see if fuel reaches the rag. If no fuel is pumped, check the connection between the motor and the fuel pump to make sure the motor can turn the pump. Also check the external and internal fuel filters for blockage, and clean or replace if necessary. The fuel pumps internal filter is usually located where the fuel inlet line enters the pump. Check to make sure motor is rotating pump. (BIE 99AM003 Gauge Kit, optional accessory)
7. Solenoid valve is defective. Call tech service for assistance.
8. Control board defective. Use a multi-meter set to measure voltage. Take a voltage reading on the control board terminals that send input power to the transformer. If proper voltage is not present, the control board is defective. Check fuse on control board.

## **ADVANCED TROUBLESHOOTING CONTINUED**

9. Defective transformer.  
Call Tech Service.

**Heater ignites, runs less than one minute and the flame/safety control trips.**

**Causes:**

1. Photocell dirty or defective.
2. Flame/safety control defective.

**Solutions:**

1. Photocell dirty or defective.

If the photocell "eye" is dirty, it may be cleaned with a soft dry cloth. Should a cleaner be necessary, use an alcohol based cleaner that will dry completely without leaving an oil residue. If the photocell is clean and this symptom continues, remove the photocell for testing. Measure resistance, if zero or infinite-replace photocell.

2. Flame/safety control defective.

The easiest way to test the flame/safety control is to prove the photocell is good or bad using one of the two preceding tests under "1. Photocell dirty or defective". If the jumper test will not run the heater or the photocell passes the ohm test, the flame/safety control is defective.

**Heater ignites, runs several minutes and shuts down.**

**Causes:**

1. Photocell dirty or defective.
2. Fuel filter dirty.
3. Fuel pump is defective.

**Solutions:**

1. Photocell dirty or defective.

See "1. Photocell dirty or defective" for instructions on cleaning and testing the photocell.

2. Fuel filter dirty.

See "1. Fuel filter dirty"

3. Fuel pump is defective.

See "6. Fuel pump is defective"



## **ADVANCED TROUBLESHOOTING CONTINUED**

### **Heater ignites, but combustion is poor or uneven.**

#### **Causes:**

1. Fuel pump is defective.
2. Spray nozzle clogged.
3. Fuel filter dirty.
4. Spark plug or electrode(s) not gapped or positioned properly.
5. Weak spark output from transformer.
6. Fuel contaminated by water or impurities.

#### **Solutions:**

1. Fuel pump is defective.  
See "6. Fuel pump is defective"

2. Spray nozzle clogged.  
See "2. Spray nozzle clogged"

3. Fuel filter dirty.  
See "1. Fuel filter dirty"

4. Spark plug or electrode(s) not gapped or positioned properly.  
See page 4.

5. Weak spark from transformer.  
See "9. Defective transformer"

6. Fuel contaminated by water or impurities.  
Using a flashlight, inspect the fuel in the tank for water or impurities. Bubbles on the bottom of the tank indicate water in the fuel tank. Water can be removed from the tank by adding an additive to the tank that is designed to dry up moisture in fuel tanks. This type of additive can be purchased at most automotive supply stores. This is also advisable if the fuel filter contains water or impurities.

### **Motor and transformer do not operate.**

#### **Causes:**

1. Incorrect or low voltage supplied to the heater.
2. Fuse in heater is blown. (no green light)
3. Thermostat defective, or not turned up to call for heat.
4. Control board is defective.
5. Reset button has not been reset. (red light on)
6. Wiring disconnected, loose or incorrect.

#### **Solutions:**

1. Incorrect or low voltage supplied to the heater. Most oil heaters require a minimum of 108 volts to operate properly. A multi-meter set to measure volts can be used to check the amount of voltage at the end of the extension cord(s). If the measured voltage is too low, the length of the extension cord (s) must be shortened or a thicker gauge extension cord must be used.

2. Fuse in heater is blown. Locate and remove the in-line fuse of the heater. Set a multi-meter to measure ohms of resistance. Place a multi-meter probe on each end of the fuse. The multi-meter should read zero ohms (continuity) or the fuse is blown. If a new fuse blows immediately, check for possible causes. Check for incorrect voltage to the heater. Make sure the total amperage draw of all equipment running on the circuit is not too great. If the supplied voltage and total amperage draw are correct, check the wiring in the heater for correctness and possible shorts.

## **ADVANCED TROUBLESHOOTING CONTINUED**

3. Thermostat is defective or not turned up to call for heat. Turn the thermostat up to the highest possible setting and try to start the heater. Next set a multi-meter to measure voltage coming out of the thermostat. If approximately 120 volts is not measured, the thermostat is defective.
4. Control board is defective. Using a multi-meter set for volts, check the hot and neutral wires which bring voltage into the control board. If proper voltage is reaching the board then the control board is defective.
5. Reset button has not been reset. Push the reset button and try to start the heater.
6. Wiring disconnected, loose or incorrect. With the heater unplugged, check the wiring from the cord to the terminal blocks, thermostat, and flame/safety control. Consult the wiring diagram of your heater to make sure all these wires are connected properly.

### **Heater ignities, but flame is excessive.**

#### **Causes:**

1. Pump pressure too high.
2. Incorrect fuel.
3. Worn nozzle.

#### **Solutions:**

1. Pump pressure too high.

Use a high pressure fuel gauge attached to the pump's gauge port to check the pump pressure. Use the pump's pressure adjustment if the pressure is higher than the manufacturer's recommended setting.

2. Incorrect fuel.

Only use fuels recommended by the specific manufacturer of the heater. Never use gasoline, thinners, solvents, or any other flammable fluid. If you suspect incorrect fuel, inspect carefully, then drain and replace if necessary.

3. Worn nozzle.

Over time, impurities in the fuel which are forced thru the nozzle under high pressure will enlarge the orifice and cause the heater to overfire or run "rich". Always check first for excessive pump pressure or incorrect fuel. If the pressure and fuel are both correct, a new nozzle is needed.

## **DF400/DF600 Sequence of Operation**

**Step 1 - Plug in power cord.** Power flows thru the fuse to five places: the power indicator light, the fuel filter heating element, the relay terminal #11, the electronic board and thru the control board to the three position on/off switch.

**Step 2 - Turn switch to the On position.** There are two choices for On with this switch. Selecting the upper On position allows for continuous operation without attaching an external thermostat control. The upper On position will return power from the On/Off switch to the control board. This will cause the control board to begin the ignition sequence. Choosing the lower On position will cycle the heater on and off with the attachment of an external thermostat control to the thermostat plug on the control panel. When the external thermostat returns power to the control board the ignition sequence is initiated.

**Step 3 - Control Board begins ignition sequence.** First the board sends power to the relay terminal #A1. This joins relay contacts #11 and #14 sending power to the motor and transformer.

**Step 4 - Control boards sends power to the solenoid valve.** After the motor and transformer have received power for approximately 7 to 10 seconds the control board will send power to the solenoid valve. If the airswitch closes, the power to the solenoid valve must travel thru an air pressure switch to reach the valve. Air switch is in series with solenoid valve.

**Step 5 - Photocell must detect flame.** After the control board sends power to the solenoid valve the photocell must detect the presence of flame in about two seconds. If flame is not detected the reset light will come on and the control board will interrupt power to the solenoid valve. The cool down phase will run as the control board will continue to power the relay and therefore the motor for 90 seconds. When flame is detected by the photocell the control board will continue to power the solenoid valve, the motor, and the transformer.

**Step 6 - Turn Control Switch to Off position.** The control board removes power to the solenoid valve and runs the motor for 90 seconds.

## 1. DIAGNOSTICS

If the control unit is in lockout status, by keeping the reset push-button pressed for about 5 seconds, the diagnostics routine will be activated and the cause leading to the lockout condition will be displayed. Pressing the reset push-button again enables to reset the device and to terminate the diagnostics routine. The following table shows a description of the diagnostics messages provided by the red LED blinking:

No. blinks of red LED	Description
2	Flame failure at the end of TS
4	Extraneous light / Flame simulation at start-up
7	Flame failure in running status
8-14	Internal failure

### FOR 2 RED BLINKS CAUSE MAY BE:

- No flame at 1st start up (review page 12 and 13)
- Other causes may be defective over heat limit switch (check for continuity)

### FOR 4 RED BLINKS CAUSE MAY BE:

- Photocell senses light before start- up (make sure cover is on and photocell installed properly)

### FOR 7 RED BLINKS CAUSE MAY BE:

- Out of fuel
- Filter or nozzle blocked
- Broken fuel line (intake sucking air)
- Bad photocell
- Overheat limit switch tripped

## 2. SIGNALLING DURING OPERATION

In the various operating conditions, the device can signal its operating status by means of a multicolour LED located on the on-board lockout signal. The meaning of the colours is the following:







	<b>Green:</b> Prepurge time (TP) – Ignition (TS) - Operating (RP)
	<b>Orange:</b> Cooling of the transformer
	<b>Red:</b> Lockout position (LO)
	<b>Flashing Green:</b> Stand-by position (SY)
	<b>Flashing Orange:</b> Stand-by position (SY) with presence of spurious flame
	<b>Green + Flashing Orange:</b> Prepurge time (TP) with presence of spurious flame

Fig. 6 – Meaning of LED signals

## 3. RESETTING THE CONTROL UNIT

When the control unit goes to non-volatile lockout, to reset the system press the reset push-button till the lockout signal turns off (< 5 seconds).

- Non-volatile lockout (manual reset), in order to reset the system, the reset button must be pressed (less than 5 seconds).
- Volatile lockout, hold reset button for a least one minute, red light should go out, let control board “reboot” for at least another minute before attempting to start again.

# Technical Specifications

TECHNICAL SPECIFICATIONS		DF400	DF600
Heat input	[kBTU/h]	400	600
Air flow	[cfm]	2.500	2.800
Efficiency	[%]	100,0	100,0
Heat output	[kBTU/h]	-	-
Fuel consumption	[gal/h]	2,83	4,32
	[lb/h]	20,07	30,65
Power supply	Phase	1	1
	Voltage [V]	120	120
	Frequency [Hz]	60	60
Electric consumption	[W]	1.170	1.240
	[A]	7,50	11,10
Nozzle	[USgal/h]	2,00-80°S	3,00-80° S
Pump pressure	[psi]	165	190
Static pressure	[in WC]	-	-
Adjustment of combustion air flap See Fig. 1 below	[in]	a 0,71 N=7.5	a 1,18
Flue diameter	[in]	---	---
Compulsory flue draft	[in WC]	---	---
Tank capacity <sup>1</sup>	[gal]	28	35,7
Dimensions <sup>1</sup> , L x W x H	[in]	62,4 x 27,6 x 39	67,9x27,6x41,2
Net Weight <sup>1</sup>	[lb]	222,7	246,7

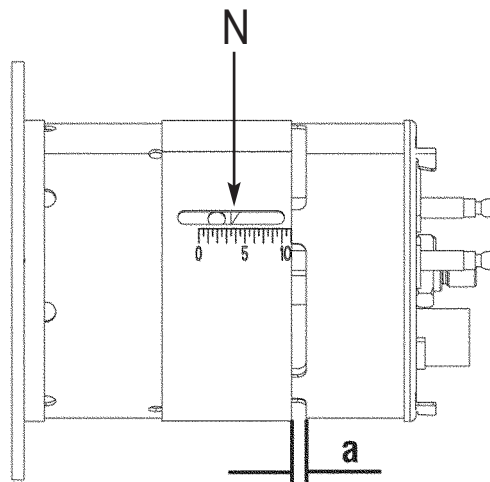

Figure 1

# Accessories



**THERMOSTAT**  
#THIDF



**EXTERNAL FUEL KIT**  
(allows access to  
external fuel source)  
#TK400



**FUEL PRESSURE GAUGE**  
#BIE99AM003

# DF400 Wiring Diagram

## SN 276000401 and Beyond

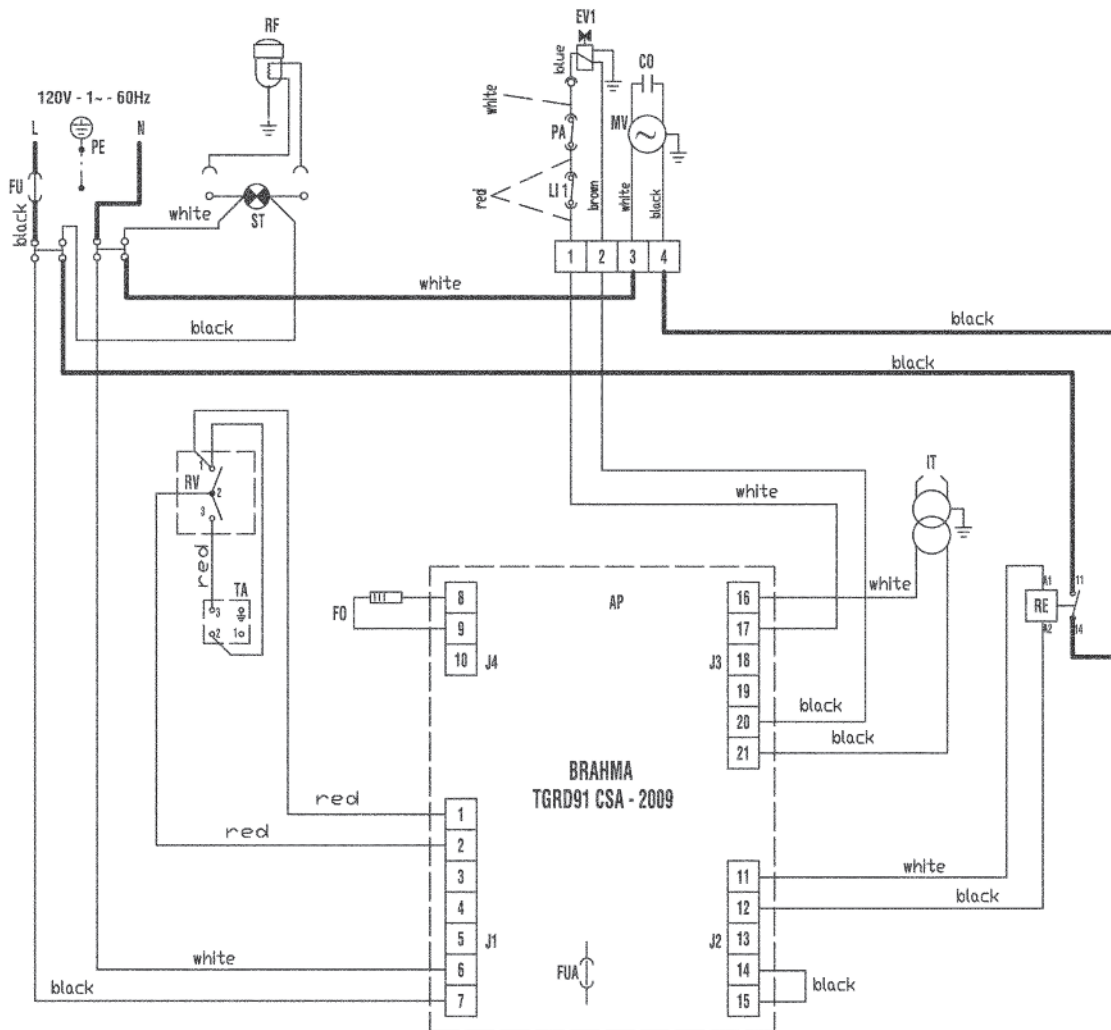

- |                                |   |
|--------------------------------|---|
| <b>FU</b> FUSE 20A             | <b>RV</b> CONTROL                       |
| <b>IT</b> TRANSFORMER H.V.     | <b>TA</b> ROOM THERMOSTAT PLUG          |
| <b>LI1</b> OVERHEAT THERMOSTAT | <b>RE</b> RELAY                         |
| <b>EV1</b> SOLENOID VALVE 1°   | <b>AP</b> CONTROL BOX                   |
| <b>FO</b> PHOTOCELL            | <b>FUA</b> FUSE 6,3A P/N - E10325       |
| <b>CO</b> CAPACITOR            | <b>RF</b> HEATED FILTER                 |
| <b>MV</b> FAN MOTOR            | <b>PA</b> AIR PRESSURE SWITCH (100 MPa) |
| <b>ST</b> ELECTRIC PILOT LAMP  |   |

# DF600 Wiring Diagram

## SN 277000401 and Beyond

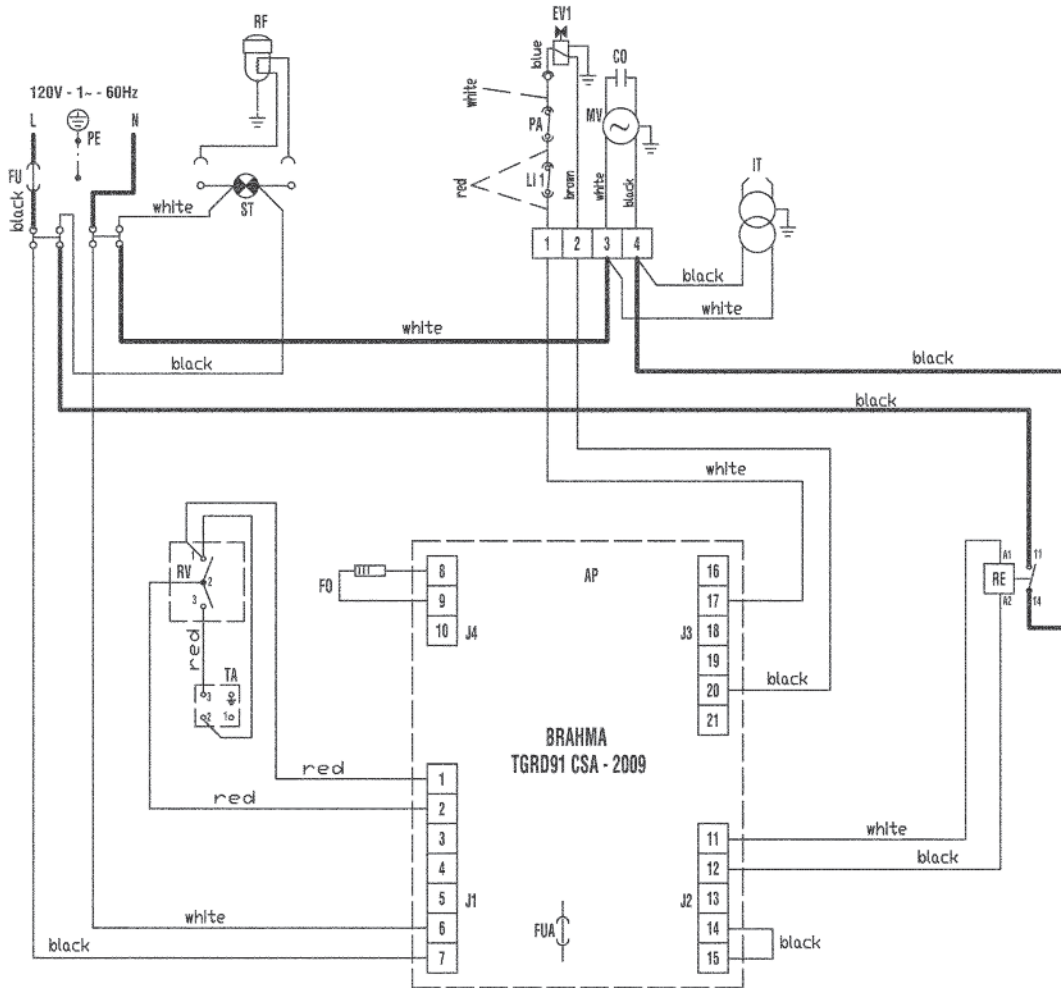

- |     |                     |     |                               |
|-----|---------------------|-----|-------------------------------|
| FU  | FUSE 20A            | TA  | ROOM THERMOSTAT PLUG          |
| IT  | TRANSFORMER H.V.    | RE  | RELAY                         |
| LI1 | OVERHEAT THERMOSTAT | AP  | CONTROL BOX                   |
| EV1 | SOLENOID VALVE 1°   | RF  | HEATED FILTER                 |
| F0  | PHOTOCELL           | PA  | AIR PRESSURE SWITCH (200 MPa) |
| CO  | CAPACITOR           | FUA | FUSE 6.3A P/N - E10325        |
| MV  | FAN MOTOR           |     |                               |
| ST  | ELECTRIC PILOT LAMP |     |                               |
| RV  | CONTROL             |     |                               |



# DF400 Breakdown

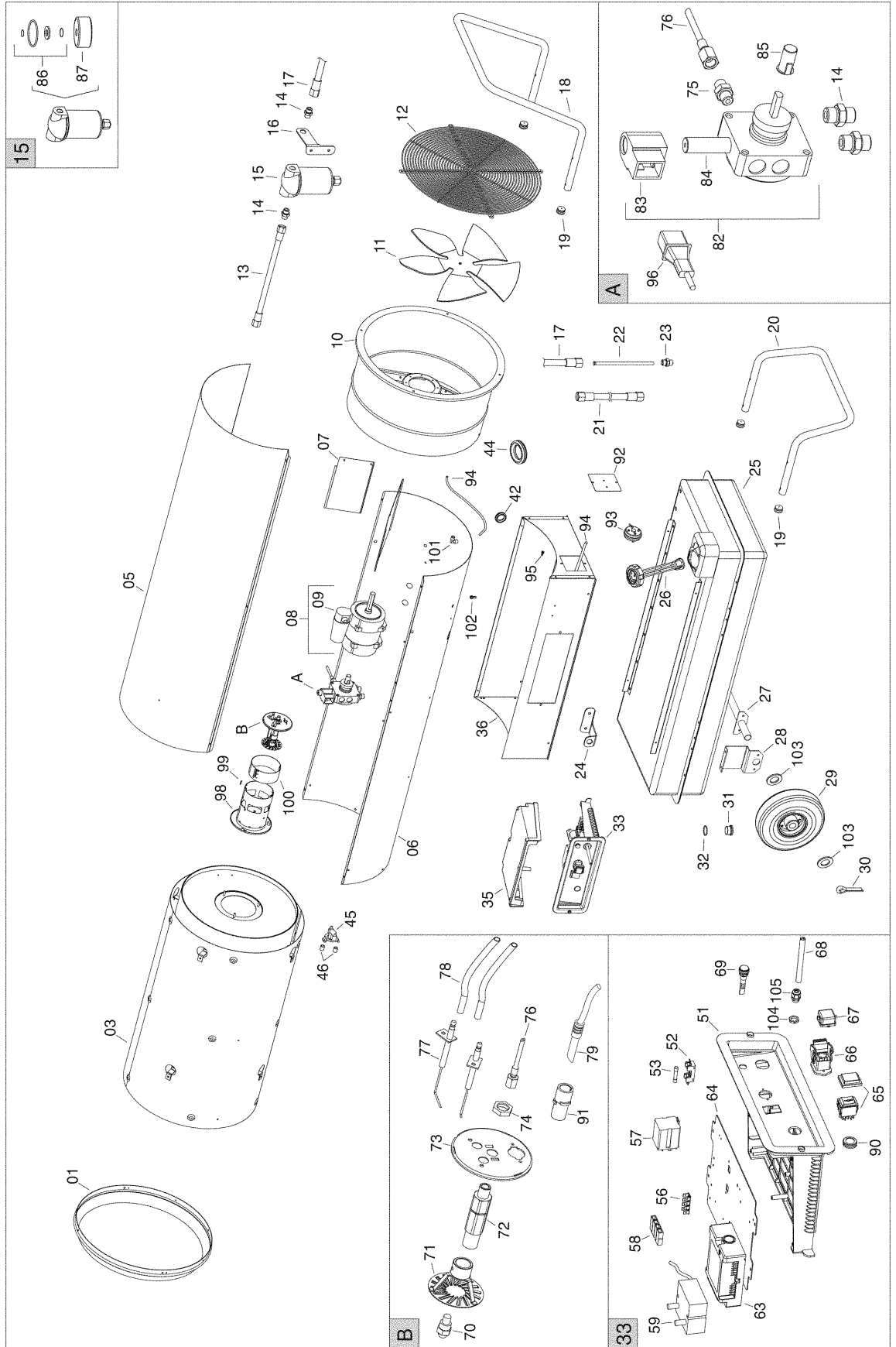

# DF400

## Parts List

POS	P/N	DESCRIPTION	POS	P/N	DESCRIPTION
01	G06139-9010	Outlet cone	58	E20305	Terminal board
03	G06231	Combustion chamber	59	E10930	H.T. Transformer
05	G06234-9010	Upper body	63	E40124	Flame control box
06	G06237-9010	Lower body	64	G06073	Support plate
07	G06397	Air conveyor	65	E10102-P	Switch
AACO			66	E20640	Thermostat plug
08	E10704-110	Motor	67	E20665	Thermostat plug cover
09	E11249	Capacitor	68	E30443	Power cord
SIMEL				E30443-1	Power cord - with fastener nut
08	E10772	Motor	69	E11030	Lamp
09	E10772-1	Capacitor	70	T20357	Nozzle
10	G06239-9010	Air conveyor	71	G01077	Diffuser ring
11	T10215-B	Fan	72	I33005	Nozzle support
12	P30129	Inlet grill	73	G06228	Burner support disc
13	I40330	Flex diesel pipe	74	I31034	Brass lock nut
14	I20104	Iron fitting	76	I40192	Micropipe
15	T20239	Diesel pre-heated filter	75	I20115	Iron fitting
16	G06104-9005	Filter support bracket	77	E10215	Ignition electrode
17	I40329	Flex diesel pipe	78	G02078	H.T. Cable connect.
18	P20176-9005	Handle	79	E50328	Photocell
19	C30355	Pipe cap	82	T20411-1	Diesel pump
20	P20177-9005	Support	83	T20118	Solenoid coil
21	I40331	Flex diesel pipe	84	T20117	Solenoid valve body
22	I30696	Suction pipe	AACO		
23	I30737	Brass fitting	85	E10514	Motor-pump coupling
24	G06068-9005	Power cord support	SIMEL		
25	G06128-9005	Fuel tank	85	E10698	Motor-pump coupling
26	02AC508	Cap with level control	86	T20241	Filter seal kit
27	G06465-9005	Wheel axle	87	T20242	Filter cartridge
28	G06106-9005	Wheels axle support bracket	90	E20418	Stop button protection
29	C10510	Wheel - Hard rubber	91	E50327	Photoresistor support
	C10556	Wheel - Air filled	92	G06406-9010	Pressure switch support bracket
30	M20507	Cotter pin	93	E50440	Pressure switch
31	I25020	Drain cap	94	I40335	Silicone pipe
32	C30375	O-ring	95	I31131	Brass hose connection
33	G00248	El. control box	96	T20442	Solenoid valve cable
35	P50127	Control box cover	98	G06249	Blast tube
36	G06411-9010	Base	99	E20671	Terminal board
42	C30323	Cable protection	100	G06183	Air adjustment shutter
44	C30372	Cable protection	101	I20325	Fitting
45	E50102	Safety thermostat	102	I31130	Brass hose connection
46	G06072	Spacer	103	M20111	Washer
51	G06153	El. control box panel	104	E20965	Cable fastener nut
52	E20508	Fuse holder	105	E20964	Cable fastener
53	E10313	Fuse			
56	E20319	Ground terminal board			
57	E11125	Relay			

### Optional Thermostat

THIDF	Optional thermostat w/50' cord
7979K62	4 pin plug insert
7979K68	4 pin plug cover

# DF600 Breakdown

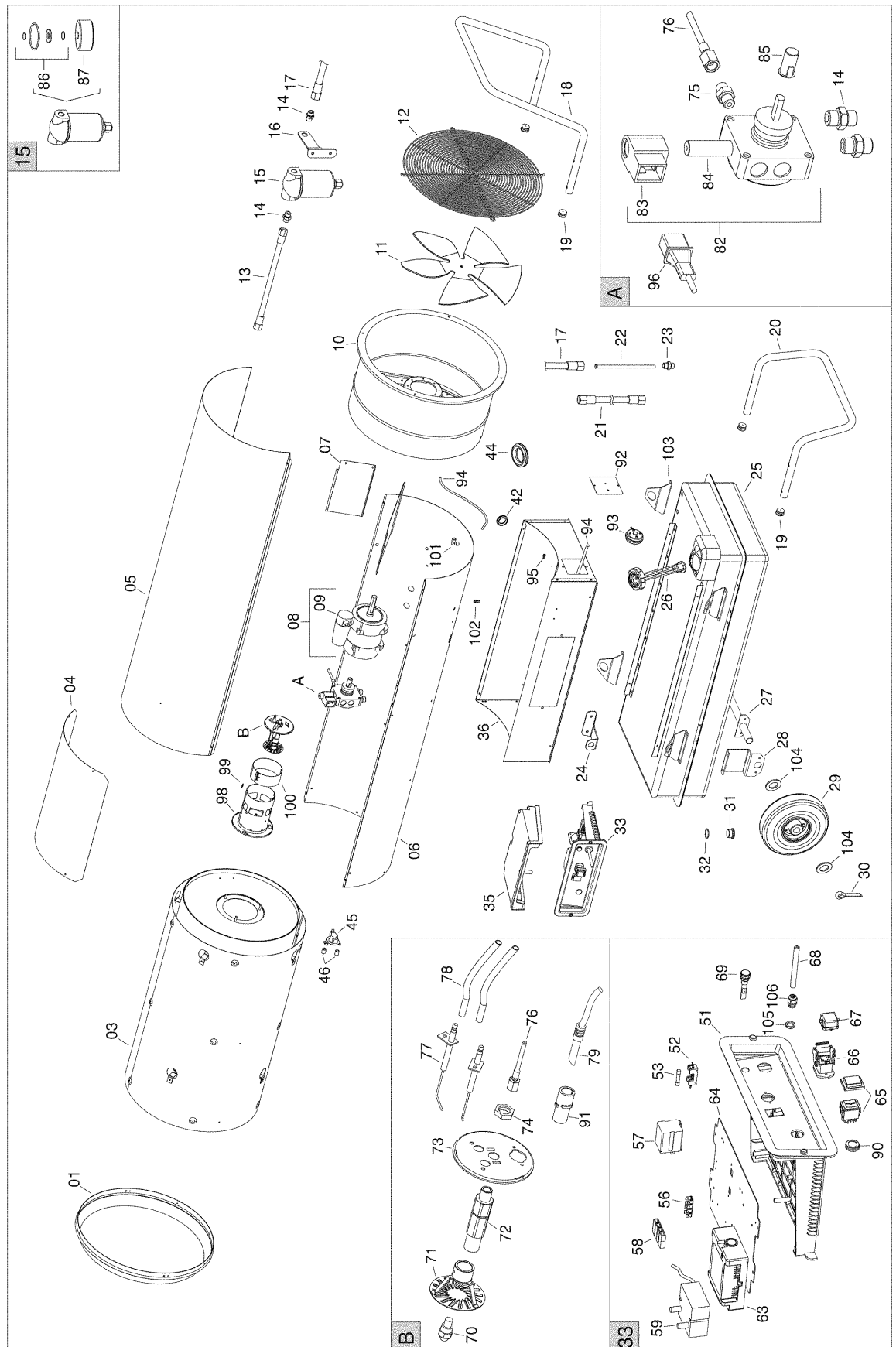

# DF600

## Parts List

POS	P/N	DESCRIPTION
01	G06139-9010	Outlet cone
03	G06232	Combustion chamber
04	G06143-9010	Panel
05	G06235-9010	Upper body
06	G06238-9010	Lower body
07	G06397	Air conveyor
AACO		
08	E10704-110	Motor
09	E11249	Capacitor
SIMEL		
08	E10772	Motor
09	E10772-1	Capacitor
10	G06239-9010	Air conveyor
11	T10263	Fan
12	P30129	Inlet grill
13	I40330	Flex diesel pipe
14	I20104	Iron fitting
15	T20239	Diesel pre-heated filter
16	G06104-9005	Filter support bracket
17	I40329	Flex diesel pipe
18	P20176-9005	Handle
19	C30355	Pipe cap
20	P20180-9005	Support
21	I40331	Flex diesel pipe
22	I30698	Suction pipe
23	I30737	Brass fitting
24	G06068-9005	Power cord support
25	G06146-9005	Fuel tank
26	O2AC510	Cap with level control
27	G06465-9005	Wheel axle
28	G06107-9005	Wheels axle support bracket
29	C10510	Wheel - Hard rubber
	C10556	Wheel - Air filled
30	M20507	Cotter pin
31	I25020	Drain cap
32	C30375	O-ring
33	G00251	El. control box
35	P50127	Control box cover
36	G06411-9010	Base
42	C30323	Cable protection
44	C30372	Cable protection
45	E50102	Safety thermostat
46	G06072	Spacer
51	G06153	El. control box panel
52	E20508	Fuse holder
53	E10313	Fuse
56	E20319	Ground terminal board
57	E11125	Relay

POS	P/N	DESCRIPTION
58	E20305	Terminal board
59	E10917-2	H.T. Transformer
63	E40124	Flame control box
64	G06073	Support plate
65	E10102-P	Switch
66	E20640	Thermostat plug
67	E20665	Thermostat plug cover
68	E30443	Power cord
	E30443-1	Power cord - with fastener nut
69	E11030	Lamp
70	T20327	Nozzle
71	G07025	Diffuser ring
72	I33005	Nozzle support
73	G06229	Burner plate
74	I31034	Brass lock nut
75	I20115	Iron fitting
76	I40192	Micropipe
77	E10215	Ignition electrode
78	G02076	H.T. Cable connect.
79	E50328	Photocell
82	T20411-1	Diesel pump
83	T20118	Solenoid coil
84	T20117	Solenoid valve body
AACO		
85	E10514	Motor-pump coupling
SIMEL		
85	E10698	Motor-pump coupling
86	T20241	Filter seal kit
87	T20242	Filter cartridge
90	E20418	Stop button protection
91	E50327	Photoresistor support
92	G06406-9010	Pressure switch support bracket
93	E50441	Pressure switch
94	I40335	Silicone pipe
95	I31131	Brass hose connection
96	T20442	Solenoid valve cable
98	G06412	Blast tube
99	E20671	Terminal board
100	G06183	Air adjustment shutter
101	I20325	Fitting
102	I31130	Brass hose connection
103	O2AC511	Lifting bracket
104	M20111	Washer
105	E20965	Cable fastener nut
106	E20964	Cable fastener

### Optional Thermostat

THIDF	Optional thermostat w/50' cord
7979K62	4 pin plug insert
7979K68	4 pin plug cover

## Accessories



**THERMOSTAT**  
#THIDF



**EXTERNAL FUEL KIT**  
(allows access to  
external fuel source)  
#TK400



**FUEL PRESSURE GAUGE**  
#BIE99AM003



342 N. Co. Rd. 400 East • Valparaiso, IN 46383  
219-464-8818 • 888-432-8924 • Fax 800-255-7985  
[www.heatwagon.com](http://www.heatwagon.com)