



Operating Instructions and Parts Manual

Electric SCH40 Pipe/Tube Notcher

Model ESN-40



JET
427 New Sanford Road
LaVergne, Tennessee 37086
Ph.: 800-274-6848
www.jettools.com

Part No. M-754420
Edition 1 08/2016
Copyright © 2016 JET



1.0 IMPORTANT SAFETY INSTRUCTIONS

WARNING – To reduce risk of injury:

1. Read and understand the entire owner's manual before attempting assembly or operation.
2. Read and understand the warnings posted on the machine and in this manual. Failure to comply with all of these warnings may cause serious injury.
3. Replace warning labels if they become obscured or removed.
4. This pipe notcher is designed and intended for use by properly trained and experienced personnel only. If you are not familiar with the proper and safe operation of a pipe notcher, do not use it until proper training and knowledge have been obtained.
5. Do not use this pipe notcher for other than its intended use. If used for other purposes, JET disclaims any real or implied warranty and holds itself harmless from any injury that may result from that use.
6. Always wear ANSI Z87.1 approved safety glasses or face shield while using this machine. (Everyday eyeglasses only have impact resistant lenses; they are *not* safety glasses.)
7. Keep hands away from notching holes when machine is connected to power.
8. Make certain the machine is properly grounded.
9. Before operating the machine, remove tie, rings, watches, other jewelry, and roll sleeves up past the elbows. Remove all loose clothing and confine long hair.
10. Keep the floor around the machine clean and free of scrap material, oil and grease.
11. Keep machine guards in place at all times when the machine is in use. If removed for maintenance purposes, use extreme caution and replace the guards immediately upon completion of maintenance.
12. Make all machine adjustments or maintenance with machine unplugged from power source.
13. Use the right tool. Do not force a tool or attachment to do a job that it was not designed to do.
14. Make certain the switch is in the **OFF** position before connecting the machine to the power supply.
15. Give your work undivided attention. Looking around, carrying on a conversation and "horse-play" are careless acts that can result in serious injury.
16. Keep visitors a safe distance from the work area. Keep children away.
17. Make your workshop child proof with padlocks, master switches or by removing starter keys.
18. Maintain a balanced stance at all times so that you do not fall onto moving parts. Do not overreach or use excessive force to perform any machine operation.
19. Use recommended accessories; improper accessories may be hazardous.
20. Some dust created by power sanding, sawing, grinding, drilling and other construction activities contain chemicals known to cause cancer, birth defects or other reproductive harm. Some examples of these chemicals are:
 - Lead from lead based paint.
 - Crystalline silica from bricks, cement and other masonry products.
 - Arsenic and chromium from chemically treated lumber.Your risk of exposure varies, depending on how often you do this type of work. To reduce your exposure to these chemicals, work in a well-ventilated area and work with approved safety equipment, such as face or dust masks that are specifically designed to filter out microscopic particles.
21. Do not operate this machine while under the influence of drugs, alcohol or any medication.
22. Keep tools sharp and clean for safe and best performance.
23. Provide for adequate space surrounding work area and non-glare, overhead lighting.
24. Use only JET factory authorized replacement parts and accessories; otherwise, the warranty and guarantee are null and void.
25. Use proper extension cord. Make sure your extension cord is in good condition. When using an extension cord, be sure to use one heavy enough to carry the current your product will draw. An undersized cord will cause a drop in line voltage resulting in loss of power and overheating. Table 1 (sect. 6.2) shows correct size to use depending on cord length and nameplate ampere rating. If in doubt, use the next heavier gage. The smaller the gage number, the heavier the cord.

Familiarize yourself with the following safety notices used in this manual:



This means that if precautions are not heeded, it may result in minor injury and/or possible machine damage.



This means that if precautions are not heeded, it may result in serious, or possibly even fatal, injury.

SAVE THESE INSTRUCTIONS

2.0 About this manual

This manual is provided by JET, covering the safe operation and maintenance procedures for a JET Model ESN-40 Electric Pipe Notcher. This manual contains instructions on installation, safety precautions, general operating procedures, maintenance instructions and parts breakdown. Your machine has been designed and constructed to provide consistent, long-term operation if used in accordance with the instructions as set forth in this document.

If there are questions or comments, please contact your local supplier or JET. JET can also be reached at our web site: www.jettools.com.

Retain this manual for future reference. If the machine transfers ownership, the manual should accompany it.



Read and understand the entire contents of this manual before attempting assembly or operation! Failure to comply may cause serious injury!

3.0 Table of contents

Section	Page
1.0 IMPORTANT SAFETY INSTRUCTIONS	2
2.0 About this manual	3
3.0 Table of contents.....	3
4.0 Specifications	4
5.0 Setup	5
6.0 Electrical connections	5
6.1 GROUNDING INSTRUCTIONS	5
6.2 Extension cords.....	5
7.0 Operation	6
8.0 User-maintenance.....	6
8.1 Additional servicing	6
9.0 Troubleshooting ESN-40 Pipe Notcher	7
10.0 Replacement Parts.....	7
10.1.1 ESN-40 Pipe Notcher – Exploded View	8
10.1.2 ESN-40 Pipe Notcher – Parts List.....	9
11.0 Electrical Connections for ESN-40 Pipe Notcher	10
12.0 Warranty and Service.....	11

4.0 Specifications

Model number **ESN-40**
Stock number 754420

Motor and electricals:

Motor type totally enclosed fan cooled, induction, capacitor start
Horsepower 2HP (1.5 kW)
Phase single
Voltage 220V
Cycle 60Hz
Listed FLA (full load amps) 11 A
Running amps (no load) 5A
Start capacitor 200µF 250VAC
Run capacitor 30µF 450VAC
Power transfer direct drive, to eccentric shaft
On/off switch magnetic
Power cord 14AWG
Power cord length 7-1/2 ft. (229cm)
Motor cord 14AWG
Power plug installed 15A, 220V
Overload protection 15A circuit breaker with reset button
Recommended circuit size¹ 15 A
Noise emission without load² below 55 dB

Capacities:

No. of pipe diameters 8
Diameters (SCH 40) 1/4, 3/8, 1/2, 3/4, 1, 1-1/4, 1-1/2, 2 in.
Maximum wall thickness 0.133 in.
Notching 90 deg. fixed angle
Oil capacity 2.0 L

Materials:

Main body cast iron
Stand cast iron
Notching box steel

Dimensions:

Shipping dimensions (LxWxH) 820 x 450 x 480 mm (32-1/4 x 18 x 19 in.)
Overall dimensions (LxWxH) 820 x 380 x 360 mm (32-1/4 x 15 x 14 in.)

Weights:

Net weight (approx..) 98 kg (216 lb.)
Shipping weight (approx..) 112 kg (247 lb.)

¹ subject to local/national electrical codes

² The specified values are emission levels and are not necessarily to be seen as safe operating levels. As workplace conditions vary, this information is intended to allow the user to make a better estimation of the hazards and risks involved only.

L= length; W=width; H=height

The specifications in this manual were current at time of publication, but because of our policy of continuous improvement, JET reserves the right to change specifications at any time and without prior notice, without incurring obligations.

⚠WARNING Read and understand the entire contents of this manual before attempting set-up or operation! Failure to comply may cause serious injury.

5.0 Setup

Remove all crating and check for shipping damage. Report any damage immediately to your distributor and shipping agent. Do not discard any shipping material until Pipe Notcher is set up and operating properly.

Use hoist, forklift, or similar means to raise Pipe Notcher using lifting ring on top. Straps and chains must be properly rated for weight of Notcher.

The Pipe Notcher can be used in horizontal or vertical position. Mount it to a stable surface with appropriate fasteners (not provided). Make sure to leave space around machine for pipe movement and general maintenance.

Remove any protectant from the machine with a soft cloth and a cleaner-degreaser or kerosene. Do not allow solvents to contact painted or plastic areas.

6.0 Electrical connections

⚠WARNING Electrical connections must be made by a qualified electrician in compliance with all relevant codes. This machine must be properly grounded to help prevent electrical shock and possible fatal injury.

The ESN-40 Pipe Notcher is ready to run at 230-volt operation. This tool is intended for use on a circuit that has an outlet that looks like the one illustrated in Figure 6-1. The tool is intended for use with a grounding plug that looks like the plug illustrated in Figure 6-1. Make sure the tool is connected to an outlet having the same configuration as the plug. No adapter is available or should be used with this tool. If the tool must be reconnected for use on a different type of electric circuit, the reconnection should be made by qualified service personnel; and after reconnection, the tool should comply with all local codes and ordinances.

Before connecting to power source, be sure switch is in *off* position.

It is recommended that the Pipe Notcher be connected to a dedicated 15 amp circuit with a circuit breaker or fuse. If connected to a circuit protected by fuses, use time delay fuse marked "D".

NOTE: Local codes take precedence over recommendations.

6.1 GROUNDING INSTRUCTIONS

This tool must be grounded. In the event of a malfunction or breakdown, grounding provides a path of least resistance for electric current to reduce the risk of electric shock. This tool is equipped with an electric cord having an equipment-grounding conductor and a grounding plug. The plug must be inserted into an appropriate outlet that is properly installed and grounded in accordance with all local codes and ordinances.

⚠WARNING Improper connection of the equipment-grounding conductor can result in a risk of electric shock. Check with a qualified electrician or service person if you are in doubt as to whether the outlet is properly grounded. Do not modify the plug provided with the tool – if it will not fit the outlet, have a proper outlet installed by a qualified electrician.

The conductor with insulation having an outer surface that is green with or without yellow stripes is the equipment-grounding conductor. If repair or replacement of the electric cord or plug is necessary, do not connect the equipment-grounding conductor to a live terminal.

Use only 3-wire extension cords that have 3-prong grounding plugs and 3-pole receptacles that accept the tool's plug.

Repair or replace damaged or worn cord immediately.

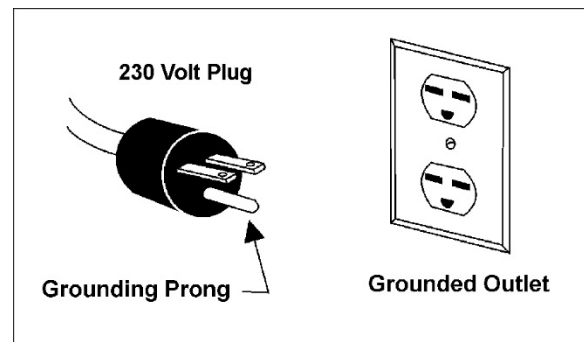

Figure 6-1: grounding

6.2 Extension cords

The use of extension cords is discouraged; try to position equipment within reach of the power source. If an extension cord becomes necessary, be sure it is heavy enough to carry the current your product will draw. An undersized cord will cause a drop in line voltage resulting in loss of power and overheating.

Table 1 shows recommended size to use depending on cord length and nameplate ampere rating. If in doubt, use the next heavier gauge. The smaller the gauge number, the heavier the cord.

Ampere Rating		Volts	Total length of cord in feet			
More Than	Not More Than		50	100	200	300
		240	AWG			
0	6		18	16	16	14
6	10		18	16	14	12
10	12		16	16	14	12
12	16		14	12	Not Recommended	

Extension Cord Recommendations

Table 1

7.0 Operation

CAUTION Make sure pipe notcher is properly lubricated before operating. Failure to comply may cause damage to machine.

The Pipe Notcher is shipped with oil in the reduction box. However, the operator should confirm this before using the machine! See sect. 8.0.

1. Turn on machine.
2. Clean pipe end of any dirt, chips, burrs, etc.
3. Insert end of pipe into correct hole, determined by nominal size of schedule 40 pipe (see Figure 7-1). **NOTE: Insert only one pipe at a time into the machine.**
4. Continue to lightly press pipe into hole until it slides farther in and is notched. Pull pipe out. The scrap will fall to bottom of machine.
5. Remove pipe. It is now ready for saddling and welding.

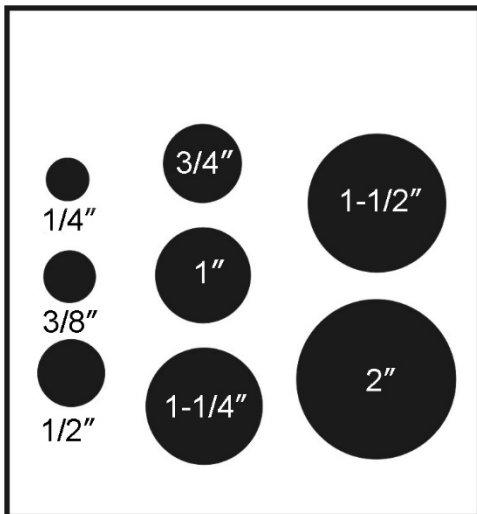

Figure 7-1:

Sizes represent nominal dimensions of SCH 40 pipe

8.0 User-maintenance

WARNING Disconnect machine from power supply before performing any maintenance. Failure to comply may result in serious injury.

1. It is recommended that the oil be replaced every 2,500 operating hours. Remove set screw to drain (Figure 8-1).
Capacity - 2.0L. (approximate)
Recommended oil - see Table 2.
2. Remove cover and clean out any lingering chips or debris around blade area, as needed.
3. Periodically check tightness of all screws.

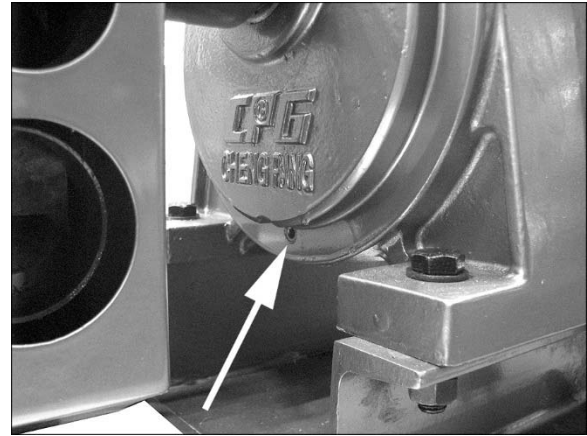

Figure 8-1: oil drain

Ambient temp.	SHELL OIL	MOBIL OIL	ISO VG
5°C~20°C	OMALA 150	MOBIL Gear 629	EP 150
20°C~40°C	OMALA 320	MOBIL Gear 632	EP 320
40°C~80°C	OMALA 460	MOBIL Gear 634	EP 460

Table 2

8.1 Additional servicing

Any additional servicing should be performed by an authorized JET service center.

9.0 Troubleshooting ESN-40 Pipe Notcher

Table 3

Symptom	Possible Cause	Correction *
Motor stalls.	Power line overloaded.	Correct overload condition.
	Insufficient lubrication of blade.	Check reservoir; top off as needed.
	Oversize material.	Make sure material is within thickness specification of machine.
	Blade is jammed.	(see following symptom)
	Low voltage.	Request voltage check from power company and correct low voltage condition.
	Motor is worn or faulty.	Replace motor.
Blade jams, or sticks during movement.	Scrap piece stuck in blade area.	Remove cover and clean blade area. Use a soft mallet if needed to dislodge pieces. Do NOT use a steel-face hammer
	Insufficient lubrication of blade.	Check reservoir; top off as needed.
	Blade is worn or has burrs.	Remove blade and carefully hone, or replace, if needed.

* **WARNING:** Some corrections may require a qualified electrician.

10.0 Replacement Parts

Replacement parts are listed on the following pages. To order parts or reach our service department, call 1-800-274-6848 Monday through Friday, 8:00 a.m. to 5:00 p.m. CST. Having the Model Number and Serial Number of your machine available when you call will allow us to serve you quickly and accurately.

Non-proprietary parts, such as fasteners, can be found at local hardware stores, or may be ordered from JET. Some parts are shown for reference only, and may not be available individually.

10.1.1 ESN-40 Pipe Notcher – Exploded View

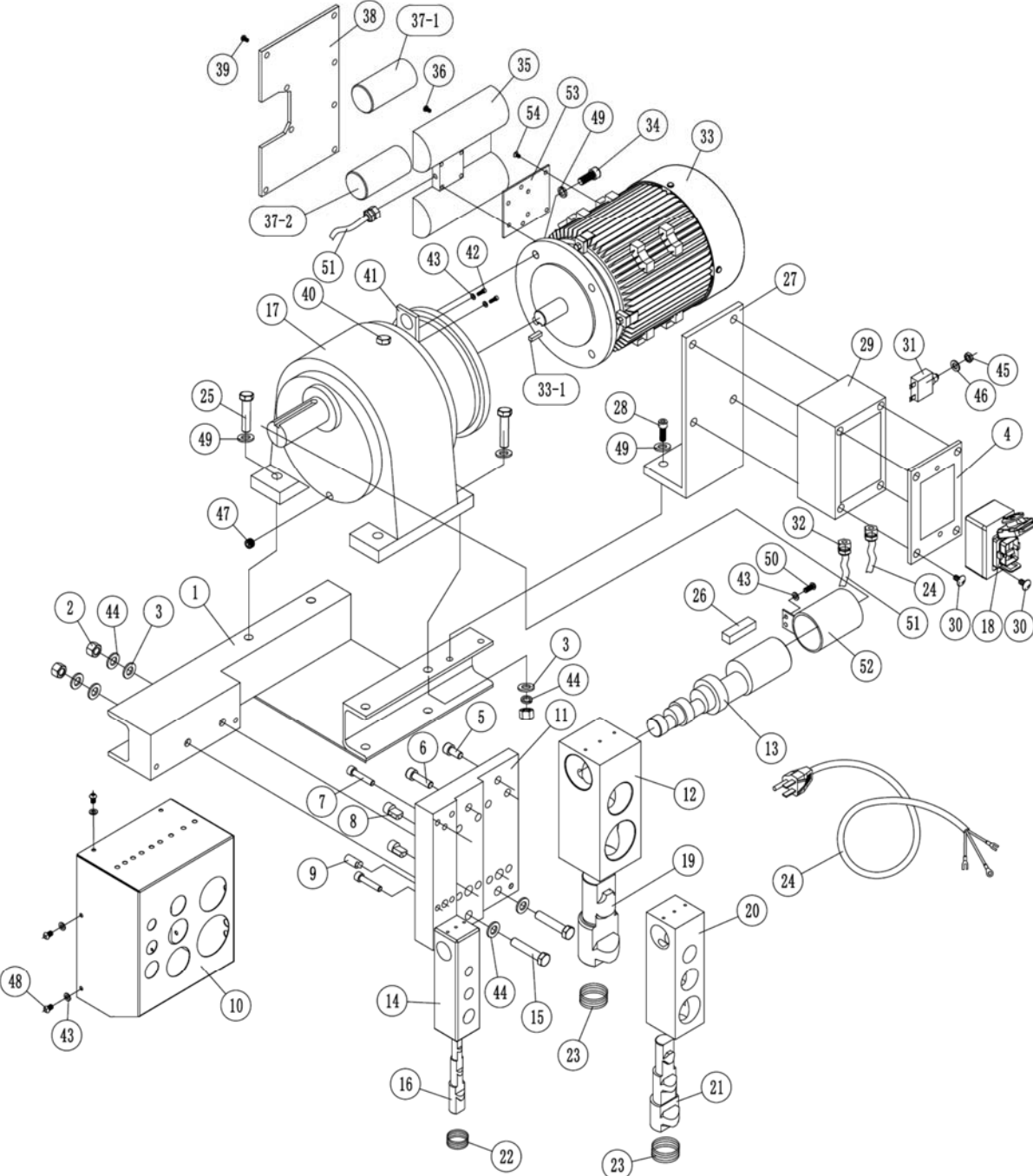

10.1.2 ESN-40 Pipe Notcher – Parts List

Index No.	Part No.	Description	Size	Qty
1	ESN40-01	Stand I		1
2	TS-1540081	Hex Nut	M12	6
3	TS-2360121	Flat Washer	12mm	12
4	ESN40-04	Switch Plate		1
5	TS-1505021	Socket Head Cap Screw	M10x20	5
6	TS-1505061	Socket Head Cap Screw	M10x40	5
7	TS-1505051	Socket Head Cap Screw	M10x35	5
8	ESN40-08	Pin		2
9	ESN40-09	Pin		2
10	ESN40-10	Cover		1
11	ESN40-11	Joint plate I		1
12	ESN40-12	Body III		1
13	ESN40-13	Eccentric shaft		1
14	ESN40-14	Body I		1
15	TS-1492061	Hex Cap Screw	M12x60	2
16	ESN40-16	Blade I		1
17	ESN40-17	Reduction Box		1
18	ESN40-18	Switch	KJD12, 230V	1
19	ESN40-19	Blade III		1
20	ESN40-20	Body II		1
21	ESN40-21	Blade II	2x20 mm	1
22	ESN40-22	Spring		1
23	ESN40-23	Spring		2
24	ESN40-24	Power Cord	14AWG	1
25	TS-1491081	Hex Cap Screw	M10x50	4
26	ESN40-26	Key	10x50 mm	1
27	ESN40-27	Support for Switch		1
28	TS-1504011	Socket Head Cap Screw	M8x10	2
29	ESN40-29	Box for Magnetic Switch		1
30	F011287	Phillips Pan Hd Tapping Screw	#8x1/2 (ST4.2x13)	2
31	ESN40-31	Thermal Overload Protector		1
32	ESN40-32	Cord Clamp		2
33	ESN40-33	Motor	2HP 230V 1PH	1
33-1	ESN40-33-1	Key (not shown)	8x35 mm	1
	ESN40-33-2	Motor Fan Cover (not shown)		1
	ESN40-33-3	Motor Fan (not shown)		1
34	TS-1491031	Hex Cap Screw	M10x25	4
35	ESN40-35	Junction Box		1
36	TS-2284082	Phillips Pan Head Machine Screw	M4x8	4
37-1	ESN40-37-1	Starting Capacitor	250V 200µf	1
37-2	ESN40-37-2	Running Capacitor	450V 30µf	1
38	ESN40-38	Junction Box Cover		1
39	ESN40-39	Self-Tapping Screw	ST4.2x20	4
40	ESN40-40	Oil Fill Plug		1
41	ESN40-41	Lifting Ring		1
42	TS-1503041	Socket Head Cap Screw	M6x16	2
43	TS-2361061	Lock Washer	6 mm	10
44	TS-2361011	Lock Washer	12 mm	6
45	TS-2311121	Hex Nut	M12	1
46	F002101	Lock Washer, Int. Tooth	12 mm	1
47	ESN40-47	Drain Plug Screw		1
48	TS-1534032	Machine Screw, Pan Head, Phillips	M6x10	6
49	TS-2361101	Lock Washer	10 mm	4
50	TS-1534052	Machine Screw, Pan Head, Phillips	M6x16	2
51	ESN40-51	Wire		1
52	ESN40-52	Guard		1
53	ESN40-53	Junction plate		1
54	TS-2284082	Machine Screw, Pan Head, Phillips	M4x8	4

..... LM000218	ID Label, ESN-40 (not shown).....	1
..... LM000219	Warning Label (not shown).....	1
..... LM000230	Label – hole size (not shown).....	1
..... JET-92.....	JET Logo (not shown)	92x38mm

11.0 Electrical Connections for ESN-40 Pipe Notcher

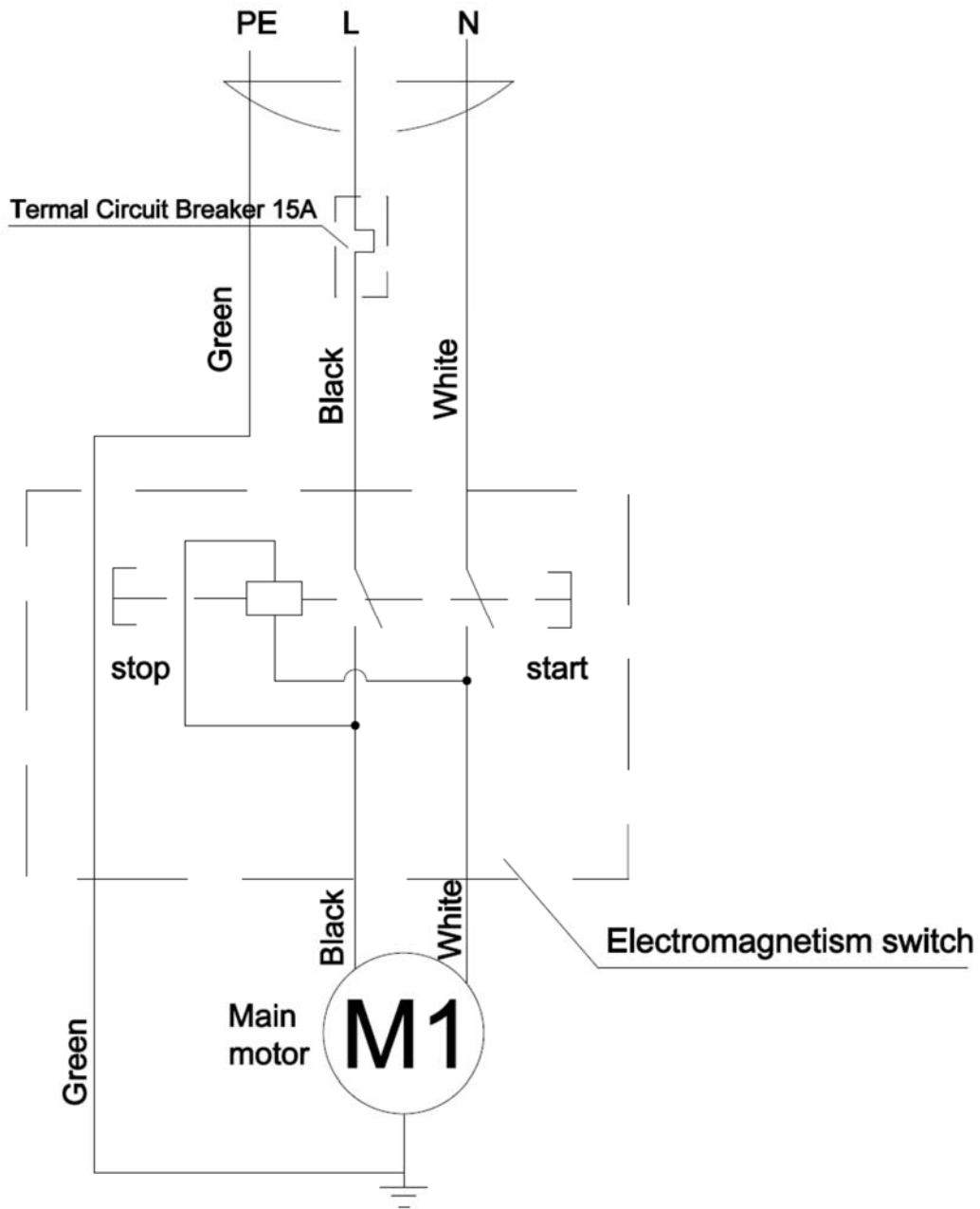

12.0 Warranty and Service

JET warrants every product it sells against manufacturers' defects. If one of our tools needs service or repair, please contact Technical Service by calling 1-800-274-6846, 8AM to 5PM CST, Monday through Friday.

Warranty Period

The general warranty lasts for the time period specified in the literature included with your product or on the official JET branded website.

- JET products carry a limited warranty which varies in duration based upon the product. (See chart below)
- Accessories carry a limited warranty of one year from the date of receipt.
- Consumable items are defined as expendable parts or accessories expected to become inoperable within a reasonable amount of use and are covered by a 90 day limited warranty against manufacturer's defects.

Who is Covered

This warranty covers only the initial purchaser of the product from the date of delivery.

What is Covered

This warranty covers any defects in workmanship or materials subject to the limitations stated below. This warranty does not cover failures due directly or indirectly to misuse, abuse, negligence or accidents, normal wear-and-tear, improper repair, alterations or lack of maintenance. JET woodworking machinery is designed to be used with Wood. Use of these machines in the processing of metal, plastics, or other materials may void the warranty. The exceptions are acrylics and other natural items that are made specifically for wood turning.

Warranty Limitations

Woodworking products with a Five Year Warranty that are used for commercial or industrial purposes default to a Two Year Warranty. Please contact Technical Service at 1-800-274-6846 for further clarification.

How to Get Technical Support

Please contact Technical Service by calling 1-800-274-6846. **Please note that you will be asked to provide proof of initial purchase when calling.** If a product requires further inspection, the Technical Service representative will explain and assist with any additional action needed. JET has Authorized Service Centers located throughout the United States. For the name of an Authorized Service Center in your area call 1-800-274-6846 or use the Service Center Locator on the JET website.

More Information

JET is constantly adding new products. For complete, up-to-date product information, check with your local distributor or visit the JET website.

How State Law Applies

This warranty gives you specific legal rights, subject to applicable state law.

Limitations on This Warranty

JET LIMITS ALL IMPLIED WARRANTIES TO THE PERIOD OF THE LIMITED WARRANTY FOR EACH PRODUCT. EXCEPT AS STATED HEREIN, ANY IMPLIED WARRANTIES OF MERCHANTABILITY AND FITNESS FOR A PARTICULAR PURPOSE ARE EXCLUDED. SOME STATES DO NOT ALLOW LIMITATIONS ON HOW LONG AN IMPLIED WARRANTY LASTS, SO THE ABOVE LIMITATION MAY NOT APPLY TO YOU.

JET SHALL IN NO EVENT BE LIABLE FOR DEATH, INJURIES TO PERSONS OR PROPERTY, OR FOR INCIDENTAL, CONTINGENT, SPECIAL, OR CONSEQUENTIAL DAMAGES ARISING FROM THE USE OF OUR PRODUCTS. SOME STATES DO NOT ALLOW THE EXCLUSION OR LIMITATION OF INCIDENTAL OR CONSEQUENTIAL DAMAGES, SO THE ABOVE LIMITATION OR EXCLUSION MAY NOT APPLY TO YOU.

JET sells through distributors only. The specifications listed in JET printed materials and on official JET website are given as general information and are not binding. JET reserves the right to effect at any time, without prior notice, those alterations to parts, fittings, and accessory equipment which they may deem necessary for any reason whatsoever. JET® branded products are not sold in Canada by JPW Industries, Inc.

Product Listing with Warranty Period

90 Days – Parts; Consumable items
1 Year – Motors; Machine Accessories
2 Year – Metalworking Machinery; Electric Hoists, Electric Hoist Accessories; Woodworking Machinery used for industrial or commercial purposes
5 Year – Woodworking Machinery
Limited Lifetime – JET Parallel clamps; VOLT Series Electric Hoists; Manual Hoists; Manual Hoist Accessories; Shop Tools; Warehouse & Dock products; Hand Tools; Air Tools

NOTE: JET is a division of JPW Industries, Inc. References in this document to JET also apply to JPW Industries, Inc., or any of its successors in interest to the JET brand.



427 New Sanford Road
LaVergne, Tennessee 37086
Phone: 800-274-6848
www.jettools.com