



Operating Instructions and Parts Manual Manual Shrinker/Stretcher

Model MSS-1



JET
427 New Sanford Road
LaVergne, Tennessee 37086
Ph.: 800-274-6848
www.jettools.com

Part No. M-756018
Edition 1 09/2016
Copyright © 2016 JET



1.0 IMPORTANT SAFETY INSTRUCTIONS

WARNING – To reduce risk of injury:

1. Read and understand the entire owner's manual before attempting assembly or operation.
2. Read and understand the warnings posted on the machine and in this manual. Failure to comply with all of these warnings may cause serious injury.
3. Replace warning labels if they become obscured or removed.
4. This shrinker/stretcher is designed and intended for use by properly trained and experienced personnel only. If you are not familiar with the proper and safe operation of a shrinker/stretcher, do not use it until proper training and knowledge have been obtained.
5. Do not use this machine for other than its intended use. If used for other purposes, JET disclaims any real or implied warranty and holds itself harmless from any injury that may result from that use.
6. Always wear ANSI Z87.1 approved safety glasses or face shield while using this machine. (Everyday eyeglasses only have impact resistant lenses; they are *not* safety glasses.)
7. Before operating the machine, remove tie, rings, watches, other jewelry, and roll sleeves up past the elbows. Remove all loose clothing and confine long hair.
8. Keep the floor around the machine clean and free of scrap material, oil and grease.
9. Keep machine guards in place at all times when the machine is in use. If removed for maintenance purposes, use extreme caution and replace the guards immediately after completion of maintenance.
10. Do **not** over reach. Maintain a balanced stance at all times, so that you do not fall or lean against moving parts.
11. Use the right tool. Do not force a tool or attachment to do a job that it was not designed to do.
12. Give your work undivided attention. Looking around, carrying on a conversation and "horse-play" are careless acts that can result in serious injury.
13. Keep visitors a safe distance from the work area. Keep children away.
14. Make your workshop child proof with padlocks, master switches or by removing starter keys.
15. Use recommended accessories; improper accessories may be hazardous.
16. **CALIFORNIA PROPOSITION 65 WARNING:** This product contains chemicals known to the State of California to cause cancer, or birth defects or other reproductive harm.
17. This product, when used for welding, cutting, or working with metal, produces fumes, gases, or dusts which contain chemicals known to the State of California to cause birth defects and, in some cases, cancer. (California Health and Safety Code Section 25249.5 et seq.)
18. Do not operate this machine while under the influence of drugs, alcohol or any medication.
19. Keep tools sharp and clean for safe and best performance.
20. Provide for adequate space surrounding work area and non-glare, overhead lighting.
21. Use only JET factory authorized replacement parts and accessories; otherwise, the warranty and guarantee are null and void.
22. Use caution handling metal workpieces. Wear leather gloves to prevent cuts from sharp edges.
23. Keep fingers away from jaws, cams and other pinch points during operation.
24. When finished using the tool, insert the locking pin to prevent foot pedal movement.

Familiarize yourself with the following safety notices used in this manual:

⚠CAUTION This means that if precautions are not heeded, it may result in minor injury and/or possible machine damage.

⚠WARNING This means that if precautions are not heeded, it may result in serious, or possibly even fatal, injury.

SAVE THESE INSTRUCTIONS

2.0 About this manual

This manual is provided by JET, covering safe operation and maintenance procedures for a JET Model MSS-1 Manual Shrinker/Stretcher. This manual contains instructions on installation, safety precautions, general operating procedures, maintenance instructions and parts breakdown. Your machine has been designed and constructed to provide consistent, long-term operation if used in accordance with the instructions as set forth in this document.

If there are questions or comments, please contact your local supplier or JET. JET can also be reached at our web site: www.jettools.com.

Retain this manual for future reference. If the machine transfers ownership, the manual should accompany it.

⚠WARNING Read and understand the entire contents of this manual before attempting assembly or operation! Failure to comply may cause serious injury!

Register your product online -

<http://www.jettools.com/us/en/service-and-support/warranty/registration/>

3.0 Table of contents

Section	Page
1.0 IMPORTANT SAFETY INSTRUCTIONS	2
2.0 About this manual	3
3.0 Table of contents.....	4
4.0 Specifications for Shrinker-Stretcher.....	4
5.0 Setup and assembly.....	5
5.1 Shipping contents.....	5
5.2 Additional tools required.....	5
5.3 Assembly.....	5
5.4 Installing jaw sets	6
5.5 Locking pin	6
6.0 Operation	7
6.1 General instructions and tips.....	7
6.2 General procedure for flange	7
7.0 User-maintenance.....	7
7.1 Lubrication.....	7
7.2 Additional servicing	7
8.0 Replacement Parts.....	7
8.1.1 MSS-1 Shrinker/Stretcher – Exploded View.....	8
8.1.2 MSS-1 Shrinker/Stretcher – Parts List	9
9.0 Warranty and Service.....	10

4.0 Specifications for Shrinker-Stretcher

Model number	MSS-1
Stock number	756018

Capacities:

Maximum thickness capacity, mild steel.....	16 ga.
Maximum thickness capacity, aluminum	18 ga.
Throat depth	6 in. (152.4 mm)
Throat height.....	2.5 in. (63.5 mm)
Maximum flange capacity	1-1/8 in. (28.6 mm)

Main materials:

Base.....	steel tubing
Wheels.....	plastic
Stand	steel plate
Jaws.....	hardened steel, HRC 40~45

Dimensions:

Overall dimensions, assembled (LxWxH).....	920 x 410 x 1175 mm (36-7/32 x 16-9/64 x 46-17/64 in.)
Shipping dimensions (LxWxH).....	118 x 50 x 21 mm (46-1/2 x 19-5/8 x 8-1/4 in.)

Weights:

Net weight (approx.).....	38 kg (84 lb)
Shipping weight (approx.)	50 kg (110 lb)

L= length; W=width; H=height

The specifications in this manual were current at time of publication, but because of our policy of continuous improvement, JET reserves the right to change specifications at any time and without prior notice, without incurring obligations.

⚠WARNING Read and understand the entire contents of this manual before attempting set-up or operation! Failure to comply may cause serious injury.

5.0 Setup and assembly

Open shipping container and check for shipping damage. Report any damage immediately to your distributor and shipping agent. Do not discard any shipping material until machine is assembled and running properly.

Compare contents of your container with the following parts list to make sure all parts are intact. Missing parts, if any, should be reported to your distributor. Read instruction manual thoroughly for assembly, maintenance and safety instructions.

5.1 Shipping contents

- 1 Stand assembly
- 1 Base with wheels
- 1 Foot pedal
- 1 Foot pedal axle
- 4 Socket head cap screws, M10x20
- 4 Flat washers, M10
- 1 Spring
- 1 Link rod
- 1 Link rod axle
- 2 Jaw sets
- 1 Hex key, 6mm
- 1 Operating Instructions & Parts List
- 1 Warranty card

5.2 Additional tools required

Hex key, 8mm (not provided)

5.3 Assembly

1. Place base (A, Figure 5-1) on floor, and mount stand (B) using four M10x20 socket hd. screws and washers (C). Tighten screws securely.

For more permanent installation, stand may be secured directly to floor, using lag screws (not provided) or similar means, through the four holes.

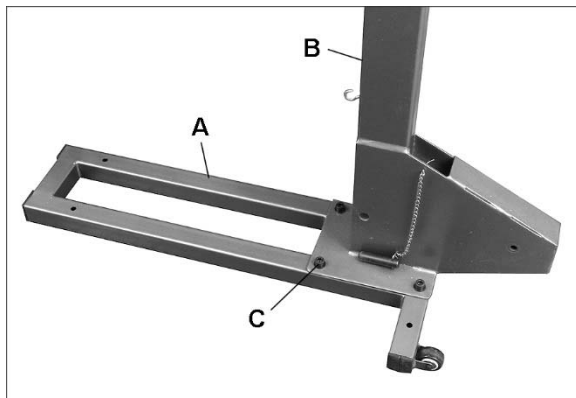

Figure 5-1

2. Insert foot pedal assembly (D, Figure 5-2) into stand. Make sure threaded link stud (E) is pointed toward stand.
3. Continue inserting foot pedal assembly, while guiding link stud up into recess, as shown in Figure 5-3.

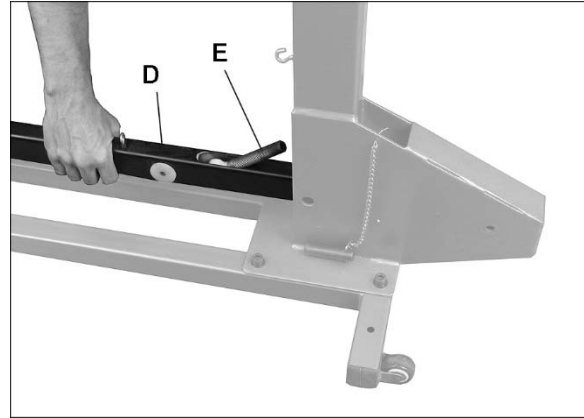

Figure 5-2

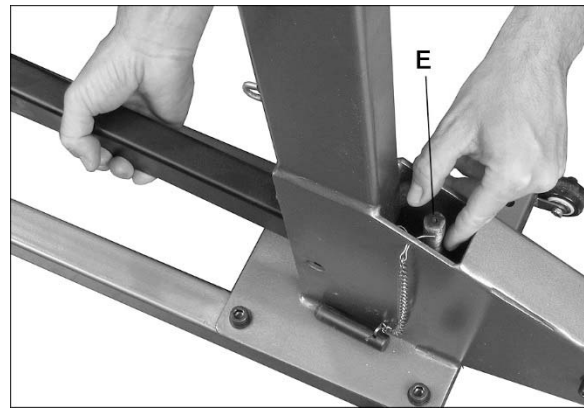

Figure 5-3

4. Align foot pedal pivot shaft with hole in stand, and insert M10x16 socket head cap screw with washer (F, Figure 5-4) into each side of hole. Make sure threaded link stud (E) remains within recess. Tighten screws securely with 8mm hex key.
5. Install spring (G, Figure 5-4), first attaching it to stand, then to foot pedal bar.

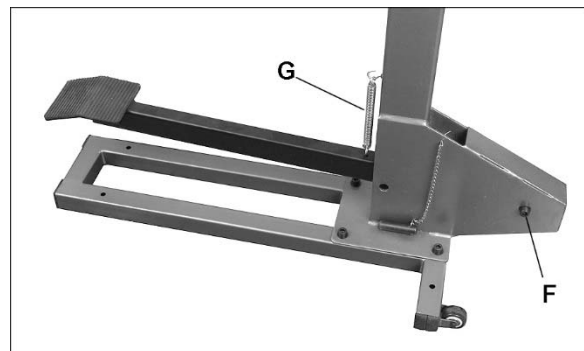

Figure 5-4

- Install link bar (H, Figure 5-5) onto link stud (E) clockwise about 15 turns.

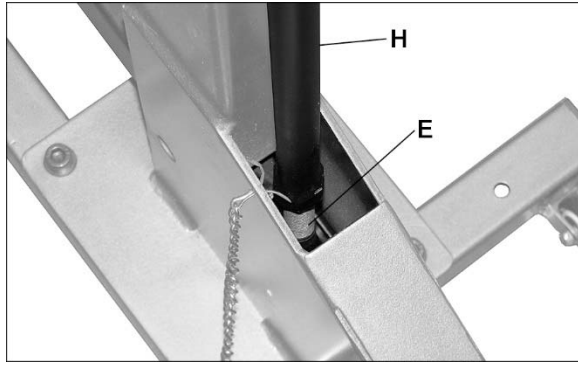

Figure 5-5

- Use any available items to block up foot pedal to approximately 7-1/2 inches from top of base. See Figure 5-6. (If stand is secured directly to floor, measurement will be from floor.)

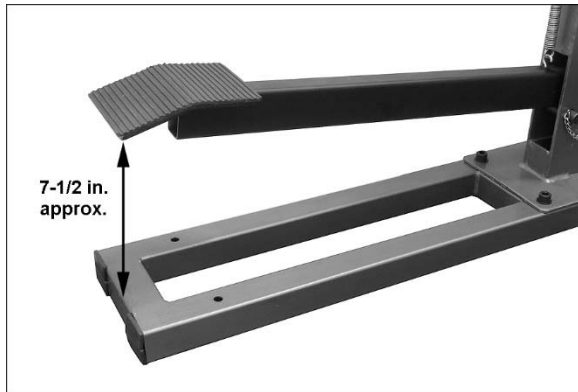

Figure 5-6

- Continue turning link bar until top end of link bar aligns with holes in upper rocker assembly, as shown in Figure 5-7.
- Install M8x16 socket head screw and washer into both ends of pivot assembly, and tighten screws securely with 6mm hex key.
- Remove blocking from beneath foot pedal.



Figure 5-7

5.4 Installing jaw sets

Two jaws sets are provided – one for shrinking, one for stretching.

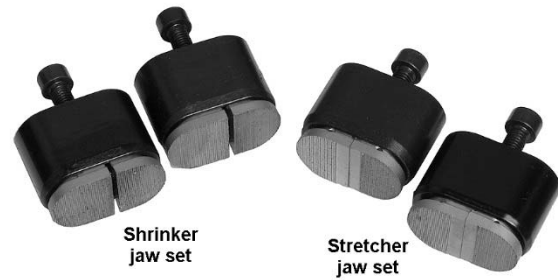

Figure 5-8

Select both jaws *from the same set*, and slide them into frame, as shown in Figure 5-9. Adjust screw if needed until jaws can be inserted. Top and bottom jaws are identical, but must have matching orientation when installed.

Tighten both socket head screws (F) with 6mm hex key. Make sure jaws remain aligned while tightening.

Store unused jaws in the attached tray, and hex key in the attached tube.

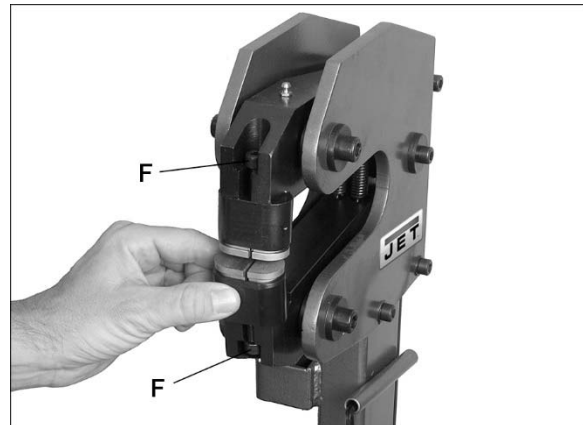

Figure 5-9

5.5 Locking pin

When machine is not being used, insert clevis pin into hole (Figure 5-10). This prevents foot pedal movement and inadvertent clamping of the jaws.

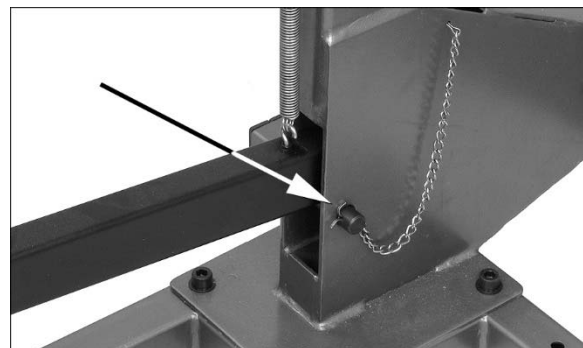

Figure 5-10

6.0 Operation

6.1 General instructions and tips

The shrinker/stretcher is used extensively in automotive body industry for window channels, wheel wells, dog legs and many other forms. Compound curves are easily accomplished on this machine by working alternate sides of the workpiece.

Use a roller stand or other device to support very long pieces.

Some users make a cardboard template of desired shape, and frequently compare it to the workpiece as it progresses.

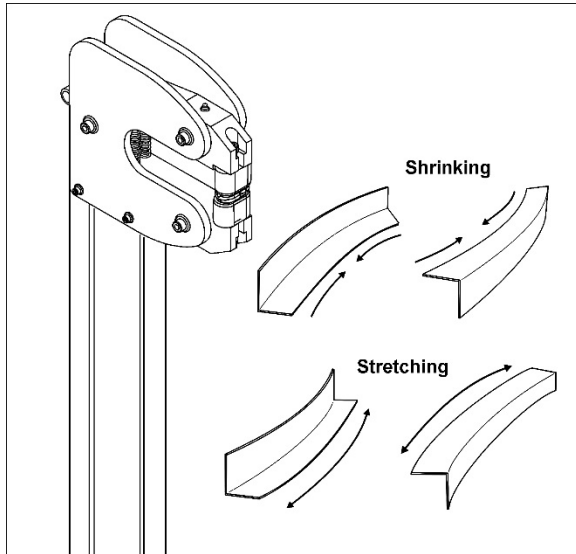

Figure 6-1

CAUTION Do not apply force to foot pedal without a piece of sheet metal between jaws. This will hasten jaw wear and may result in jaw breakage.

8.0 Replacement Parts

Replacement parts are listed on the following pages. To order parts or reach our service department, call 1-800-274-6848 Monday through Friday, 8:00 a.m. to 5:00 p.m. CST. Having the Model Number and Serial Number of your machine available when you call will allow us to serve you quickly and accurately.

Non-proprietary parts, such as fasteners, can be found at local hardware stores, or may be ordered from JET.

Some parts are shown for reference only, and may not be available individually.

6.2 General procedure for flange

1. Form a 90-degree bend in workpiece using sheet metal brake (not included) or similar device. Depth of flange should be 1-1/8 in. or less.
2. Position workpiece between jaws. Press foot pedal and release, moving workpiece through jaws a little at a time. Work the leading edge first, then move deeper into the workpiece.
3. The grooved jaw surfaces may leave markings on workpiece; these can be ground or polished out using fine abrasives.

7.0 User-maintenance

7.1 Lubrication

Lubrication of the shrinker/stretcher will depend upon frequency of use. However, here are general guidelines to follow.

1. Insert a multi-purpose machine oil into the fitting atop the die frame, once a month, to lubricate the linkages.
2. Keep jaws clean. Periodically clean the grooved gripping surfaces with a bristle brush (not a wire brush).

7.2 Additional servicing

Any additional servicing should be performed by an authorized service technician.

8.1.1 MSS-1 Shrinker/Stretcher – Exploded View

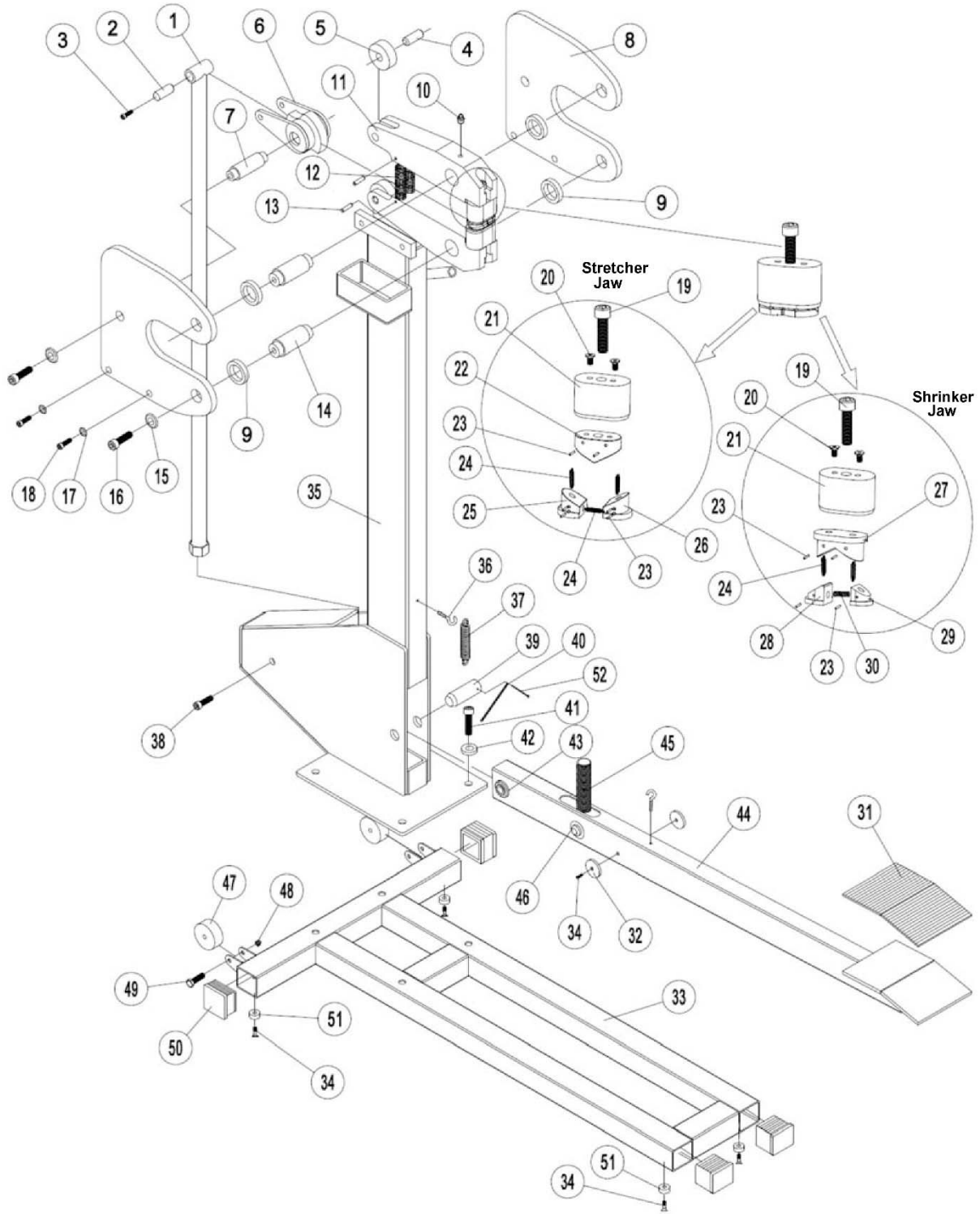

8.1.2 MSS-1 Shrinker/Stretcher – Parts List

Index No.	Part No.	Description	Size	Qty
1	MSS1-01	Link Rod		1
2	MSS1-02	Link Axle		1
3	TS-1504031	Socket Head Cap Screw	M8x16	2
4	MSS1-04	Lock Shaft		1
5	MSS1-05	Wheel		2
6	MSS1-06	Cam Rocker		1
7	MSS1-07	Cam Rocker Shaft		1
8	MSS1-08	Side Plate		2
9	MSS1-09	Set Collar		4
10	MSS1-10	Oil Fitting	M6	2
11	MSS1-11	Die Frame		2
12	MSS1-12	Die Frame Extension Spring		2
13	F012088	Roll Pin	3x30 mm	2
14	MSS1-14	Side Plate Shaft		2
15	MSS1-15	Special Washer		2
16	TS-1504041	Socket Head Cap Screw	M8x20	2
17	TS-1550061	Flat Washer	8 mm	4
18	TS-1504041	Socket Head Cap Screw	M8x20	4
19	TS-1504061	Socket Head Cap Screw	M8x30	4
20	TS-2284082	Machine Screw, Pan Head, Phillips	M4x8	8
21	MSS1-21	Outer Die Cover		4
22	MSS1-22	Inner Die Cover, Stretcher		2
23	F012089	Roll Pin	2x20 mm	20
24	MSS1-24	Extension Spring		10
25	MSS1-25	Stretcher Die 1		2
26	MSS1-26	Stretcher Die 2		2
27	MSS1-27	Inner Die Cover, Shrinker		2
28	MSS1-28	Shrinker Die 1		2
29	MSS1-29	Shrinker Die 2		2
30	MSS1-30	Extension Spring		2
31	MSS1-31	Rubber Pad *		1
32	MSS1-32	Plastic Pad		2
33	MSS1-33	Base		1
34	TS-1532032	Machine Screw, Pan Head, Phillips	M4x10	6
35	MSS1-35	Frame		1
36	MSS1-36	Pot Hook		2
37	MSS1-37	Extension Spring	3-1/8" L	1
38	TS-1505011	Socket Head Cap Screw	M10x16	2
39	MSS1-39	Clevis Pin		1
40	MSS1-40	Hanging Chain		1
41	TS-1505021	Socket Head Cap Screw	M10x20	4
42	TS-1550071	Flat Washer	10 mm	4
43	MSS1-43	Pivot Shaft		1
44	MSS1-44	Foot Pedal Weldment		1
45	MSS1-45	Link Stud		1
46	MSS1-46	Link Shaft		1
47	MSS1-47	Wheel		2
48	TS-1541021	Hex Nut, Nylon Lock	M6	2
49	TS-1482081	Hex Cap Screw	M6x40	2
50	MSS1-50	Tube Cap		4
51	MSS1-51	Plastic Washer		4
52	MSS1-52	Cotter Pin	3.2x25 mm	2
	TS-152707	Hex Wrench (not shown)	6mm	1
	LM000245	ID Label, MSS-1 (not shown)		1
	LM000239	Warning Label (not shown)		1
	JET-92	JET Logo (not shown)	92 x 38mm	1
	MSS1-STJ	Stretcher Jaw Assembly (includes #19~26)		2
	MSS1-SKJ	Shrinker Jaw Assembly (includes #19~21,23,24,27~30)		2

* requires bonding to pedal with general-purpose adhesive, not supplied

9.0 Warranty and Service

JET warrants every product it sells against manufacturers' defects. If one of our tools needs service or repair, please contact Technical Service by calling 1-800-274-6846, 8AM to 5PM CST, Monday through Friday.

Warranty Period

The general warranty lasts for the time period specified in the literature included with your product or on the official JET branded website.

- JET products carry a limited warranty which varies in duration based upon the product. (See chart below)
- Accessories carry a limited warranty of one year from the date of receipt.
- Consumable items are defined as expendable parts or accessories expected to become inoperable within a reasonable amount of use and are covered by a 90 day limited warranty against manufacturer's defects.

Who is Covered

This warranty covers only the initial purchaser of the product from the date of delivery.

What is Covered

This warranty covers any defects in workmanship or materials subject to the limitations stated below. This warranty does not cover failures due directly or indirectly to misuse, abuse, negligence or accidents, normal wear-and-tear, improper repair, alterations or lack of maintenance. JET woodworking machinery is designed to be used with Wood. Use of these machines in the processing of metal, plastics, or other materials may void the warranty. The exceptions are acrylics and other natural items that are made specifically for wood turning.

Warranty Limitations

Woodworking products with a Five Year Warranty that are used for commercial or industrial purposes default to a Two Year Warranty. Please contact Technical Service at 1-800-274-6846 for further clarification.

How to Get Technical Support

Please contact Technical Service by calling 1-800-274-6846. **Please note that you will be asked to provide proof of initial purchase when calling.** If a product requires further inspection, the Technical Service representative will explain and assist with any additional action needed. JET has Authorized Service Centers located throughout the United States. For the name of an Authorized Service Center in your area call 1-800-274-6846 or use the Service Center Locator on the JET website.

More Information

JET is constantly adding new products. For complete, up-to-date product information, check with your local distributor or visit the JET website.

How State Law Applies

This warranty gives you specific legal rights, subject to applicable state law.

Limitations on This Warranty

JET LIMITS ALL IMPLIED WARRANTIES TO THE PERIOD OF THE LIMITED WARRANTY FOR EACH PRODUCT. EXCEPT AS STATED HEREIN, ANY IMPLIED WARRANTIES OF MERCHANTABILITY AND FITNESS FOR A PARTICULAR PURPOSE ARE EXCLUDED. SOME STATES DO NOT ALLOW LIMITATIONS ON HOW LONG AN IMPLIED WARRANTY LASTS, SO THE ABOVE LIMITATION MAY NOT APPLY TO YOU.

JET SHALL IN NO EVENT BE LIABLE FOR DEATH, INJURIES TO PERSONS OR PROPERTY, OR FOR INCIDENTAL, CONTINGENT, SPECIAL, OR CONSEQUENTIAL DAMAGES ARISING FROM THE USE OF OUR PRODUCTS. SOME STATES DO NOT ALLOW THE EXCLUSION OR LIMITATION OF INCIDENTAL OR CONSEQUENTIAL DAMAGES, SO THE ABOVE LIMITATION OR EXCLUSION MAY NOT APPLY TO YOU.

JET sells through distributors only. The specifications listed in JET printed materials and on official JET website are given as general information and are not binding. JET reserves the right to effect at any time, without prior notice, those alterations to parts, fittings, and accessory equipment which they may deem necessary for any reason whatsoever. JET® branded products are not sold in Canada by JPW Industries, Inc.

Product Listing with Warranty Period

90 Days – Parts; Consumable items
1 Year – Motors; Machine Accessories
2 Year – Metalworking Machinery; Electric Hoists, Electric Hoist Accessories; Woodworking Machinery used for industrial or commercial purposes
5 Year – Woodworking Machinery
Limited Lifetime – JET Parallel clamps; VOLT Series Electric Hoists; Manual Hoists; Manual Hoist Accessories; Shop Tools; Warehouse & Dock products; Hand Tools; Air Tools

NOTE: JET is a division of JPW Industries, Inc. References in this document to JET also apply to JPW Industries, Inc., or any of its successors in interest to the JET brand.

This page intentionally left blank.



427 New Sanford Road
LaVergne, Tennessee 37086
Phone: 800-274-6848
www.jettools.com