



# Operating Instructions and Parts Manual Table Powerfeed

Models TPFA-X, TPFA-Y, TPFA-Z



**JET**

427 New Sanford Road  
LaVergne, Tennessee 37086  
Ph.: 800-274-6848  
www.jettools.com

**Part No. M-350194**  
Revision B1 08/2014  
Copyright © 2014 JET

# 1.0 Warranty and Service

JET warrants every product it sells against manufacturers' defects. If one of our tools needs service or repair, please contact Technical Service by calling 1-800-274-6846, 8AM to 5PM CST, Monday through Friday.

## Warranty Period

The general warranty lasts for the time period specified in the literature included with your product or on the official JET branded website.

- JET products carry a limited warranty which varies in duration based upon the product. (See chart below)
- Accessories carry a limited warranty of one year from the date of receipt.
- Consumable items are defined as expendable parts or accessories expected to become inoperable within a reasonable amount of use and are covered by a 90 day limited warranty against manufacturer's defects.

## Who is Covered

This warranty covers only the initial purchaser of the product from the date of delivery.

## What is Covered

This warranty covers any defects in workmanship or materials subject to the limitations stated below. This warranty does not cover failures due directly or indirectly to misuse, abuse, negligence or accidents, normal wear-and-tear, improper repair, alterations or lack of maintenance. JET woodworking machinery is designed to be used with Wood. Use of these machines in the processing of metal, plastics, or other materials may void the warranty. The exceptions are acrylics and other natural items that are made specifically for wood turning.

## Warranty Limitations

Woodworking products with a Five Year Warranty that are used for commercial or industrial purposes default to a Two Year Warranty. Please contact Technical Service at 1-800-274-6846 for further clarification.

## How to Get Technical Support

Please contact Technical Service by calling 1-800-274-6846. **Please note that you will be asked to provide proof of initial purchase when calling.** If a product requires further inspection, the Technical Service representative will explain and assist with any additional action needed. JET has Authorized Service Centers located throughout the United States. For the name of an Authorized Service Center in your area call 1-800-274-6846 or use the Service Center Locator on the JET website.

## More Information

JET is constantly adding new products. For complete, up-to-date product information, check with your local distributor or visit the JET website.

## How State Law Applies

This warranty gives you specific legal rights, subject to applicable state law.

## Limitations on This Warranty

JET LIMITS ALL IMPLIED WARRANTIES TO THE PERIOD OF THE LIMITED WARRANTY FOR EACH PRODUCT. EXCEPT AS STATED HEREIN, ANY IMPLIED WARRANTIES OF MERCHANTABILITY AND FITNESS FOR A PARTICULAR PURPOSE ARE EXCLUDED. SOME STATES DO NOT ALLOW LIMITATIONS ON HOW LONG AN IMPLIED WARRANTY LASTS, SO THE ABOVE LIMITATION MAY NOT APPLY TO YOU.

JET SHALL IN NO EVENT BE LIABLE FOR DEATH, INJURIES TO PERSONS OR PROPERTY, OR FOR INCIDENTAL, CONTINGENT, SPECIAL, OR CONSEQUENTIAL DAMAGES ARISING FROM THE USE OF OUR PRODUCTS. SOME STATES DO NOT ALLOW THE EXCLUSION OR LIMITATION OF INCIDENTAL OR CONSEQUENTIAL DAMAGES, SO THE ABOVE LIMITATION OR EXCLUSION MAY NOT APPLY TO YOU.

JET sells through distributors only. The specifications listed in JET printed materials and on official JET website are given as general information and are not binding. JET reserves the right to effect at any time, without prior notice, those alterations to parts, fittings, and accessory equipment which they may deem necessary for any reason whatsoever. JET® branded products are not sold in Canada by JPW Industries, Inc.

## Product Listing with Warranty Period

90 Days – Parts; Consumable items; Light-Duty Air Tools
1 Year – Motors; Machine Accessories; Heavy-Duty Air Tools; Pro-Duty Air Tools
2 Year – Metalworking Machinery; Electric Hoists, Electric Hoist Accessories; Woodworking Machinery used for industrial or commercial purposes
5 Year – Woodworking Machinery
Limited Lifetime – JET Parallel clamps; VOLT Series Electric Hoists; Manual Hoists; Manual Hoist Accessories; Shop Tools; Warehouse & Dock products; Hand Tools

NOTE: JET is a division of JPW Industries, Inc. References in this document to JET also apply to JPW Industries, Inc., or any of its successors in interest to the JET brand.

## 2.0 Table of Contents

Section	Page
1.0 Warranty and Service.....	2
2.0 Table of Contents.....	3
3.0 Safety Warnings.....	4
4.0 About this manual .....	5
5.0 Specifications .....	6
6.0 Setup and Assembly .....	6
6.1 Unpacking and cleanup.....	6
6.2 Shipping contents.....	7
6.3 X-Axis installation and features .....	8
6.4 X-Axis installation .....	9
6.5 Y-Axis installation .....	9
6.6 Z-Axis (Knee-lift) installation.....	10
6.7 Electrical Connections.....	12
7.0 Troubleshooting .....	13
8.0 Replacement Parts.....	13
8.1.1 Table Powerfeed – Exploded View .....	14
8.1.2 Table Powerfeed – Parts List .....	15
9.0 Electrical Connections.....	16



### 3.0 Safety Warnings

1. Read and understand the entire owner's manual before attempting assembly or operation.
2. Read and understand the warnings posted on the machine and in this manual. Failure to comply with all of these warnings may cause serious injury.
3. Replace the warning labels if they become obscured or removed.
4. This powerfeed is designed and intended for use by properly trained and experienced personnel only. If you are not familiar with the proper and safe operation of a powerfeed, do not use until proper training and knowledge have been obtained.
5. Do not use this powerfeed for other than its intended use. If used for other purposes, JET disclaims any real or implied warranty and holds itself harmless from any injury that may result from that use.
6. Before operating this powerfeed, remove tie, rings, watches and other jewelry, and roll sleeves up past the elbows. Remove all loose clothing and confine long hair. Non-slip footwear or anti-skid floor strips are recommended. Do **not** wear gloves.
7. Wear ear protectors (plugs or muffs) during extended periods of operation.
8. Some dust created by power sanding, sawing, grinding, drilling and other construction activities contains chemicals known to cause cancer, birth defects or other reproductive harm. Some examples of these chemicals are:
  - Lead from lead based paint.
  - Crystalline silica from bricks, cement and other masonry products.
  - Arsenic and chromium from chemically treated lumber.Your risk of exposure varies, depending on how often you do this type of work. To reduce your exposure to these chemicals, work in a well-ventilated area and work with approved safety equipment, such as face or dust masks that are specifically designed to filter out microscopic particles.
9. Do not operate this machine while tired or under the influence of drugs, alcohol or any medication.
10. Make certain switch is in **OFF** position before connecting machine to power supply.
11. Make certain machine is properly grounded.
12. Make all machine adjustments or maintenance with machine unplugged from power source.
13. Remove adjusting keys and wrenches. Form a habit of checking to see that keys and adjusting wrenches are removed from machine before turning it on.
14. Keep safety guards in place at all times when machine is in use. If removed for maintenance purposes, use extreme caution and replace the guards immediately after maintenance is complete.
15. Check damaged parts. Before further use of the machine, a guard or other part that is damaged should be carefully checked to determine that it will operate properly and perform its intended function. Check for alignment of moving parts, binding of moving parts, breakage of parts, mounting and any other conditions that may affect its operation. A guard or other part that is damaged should be properly repaired or replaced.
16. Provide for adequate space surrounding work area and non-glare, overhead lighting.
17. Keep the floor around the machine clean and free of scrap material, oil and grease.
18. Keep visitors a safe distance from the work area. **Keep children away.**
19. Make your workshop child proof with padlocks, master switches or by removing starter keys.
20. Give your work undivided attention. Looking around, carrying on a conversation and "horse-play" are careless acts that can result in serious injury.
21. Maintain a balanced stance at all times so that you do not fall or lean against moving parts. Do not overreach or use excessive force to perform any machine operation.
22. Use the right tool at the correct speed and feed rate. Do not force a tool or attachment to do a job for which it was not designed. The right tool will do the job better and more safely.
23. Use recommended accessories; improper accessories may be hazardous.
24. Maintain tools with care. Keep cutting tools sharp and clean for the best and safest performance. Follow instructions for lubricating and changing accessories.
25. Turn off the machine and disconnect from power before cleaning. Use a brush or compressed air to remove chips or debris — do not use your hands.
26. Do not stand on the machine. Serious injury could occur if the machine tips over.

27. Never leave the machine running unattended.  
Turn the power off and do not leave the machine until it comes to a complete stop.
28. Remove loose items and unnecessary work pieces from the area before starting the machine.

**Familiarize yourself with the following safety notices used in this manual.**

**⚠CAUTION** This means that if precautions are not heeded, it may result in minor injury and/or possible machine damage.

**⚠WARNING** This means that if precautions are not heeded, it may result in serious or even fatal injury.

## **4.0 About this manual**

This manual is provided by JET for the JET Table Powerfeed. This manual contains instructions on installation, safety precautions, general operating procedures, maintenance instructions and parts breakdown. Your powerfeed has been designed and constructed to provide years of trouble-free operation if used in accordance with instructions set forth in this document.

If there are questions or comments, please contact your local supplier or JET. JET can also be reached at our web site: [www.jettools.com](http://www.jettools.com).

Retain this manual for future reference. If the powerfeed transfers ownership, the manual should accompany it.

## 5.0 Specifications

Model number .....	TPFA-X .....	TPFA-Y .....	TPFA-Z .....
Stock number .....	350194 .....	350195 .....	350196 .....
Table movement .....	X-axis (longitudinal) .....	Y-axis (crossfeed) .....	Z-axis .....
Speed rate, variable .....	0-32 ipm (0-812.8 mm/m) .....	0-32 ipm (0-812.8 mm/m) .....	0-32 ipm (0-812.8 mm/m) .....
Maximum torque (in/lb) .....	780 .....	780 .....	780 .....
Maximum rotation .....	160 rpm .....	160 rpm .....	160 rpm .....
Rapid traverse .....	32 ipm (812.8 mm/m) .....	32 ipm (812.8 mm/m) .....	32 ipm (812.8 mm/m) .....
Leadscrew pitch .....	5 tpi (5.08 t/mm) .....	5 tpi (5.08 t/mm) .....	5 tpi (5.08 t/mm) .....
Motor .....	105W/1Amp, 115V, 1PH .....	105W/1Amp, 115V, 1PH .....	105W/1Amp, 115V, 1PH .....
Net weight .....	12.76 lb .....	12.76 lb .....	12.76 lb .....
Shipping weight .....	14.3 lb .....	14.3 lb .....	14.3 lb .....
Shipping dimensions .....	10.5"L x 6.9"W x 14.56"H .....	10.5"L x 6.9"W x 14.56"H .....	10.5"L x 6.9"W x 14.56"H .....

*The specifications in this manual were current at time of publication, but because of our policy of continuous improvement, JET reserves the right to change specifications at any time and without prior notice, without incurring obligations.*

## 6.0 Setup and Assembly

### 6.1 Unpacking and cleanup

Open shipping container and check for shipping damage. Report any damage immediately to your distributor and shipping agent. Do not discard any shipping material until the powerfeed is assembled and running properly.

Compare the contents of your container with the following parts list to make sure all parts are intact. Missing parts, if any, should be reported to your distributor. Read the instruction manual thoroughly for assembly, maintenance and safety instructions.

Some parts may have been given a protective coating. Remove this using a soft cloth and a cleaner degreaser.

## 6.2 Shipping contents

Refer to Figures 1 through 4:

- A – Powerfeed with attached limit switch
- B – Bevel gear with dial nut
- C – Socket head cap screws
- D – Cable clamps, w/ screws and washers
- E – Cable ties
- F – Set of large shims
- G – Set of small shims
- H – Travel stops
- J – Crank handle
- K – Adaptor
- L – Washer with keyway
- M – Bushing
- N – Bushing
- P – Nut (p/n TPFA2-0001)
- R – Spacer
- S – Plate w/fasteners
- T – Roll pin
- U – T-way track pieces w/ fasteners
- V – Connector base
- W – Limit switch mounting bracket w/ screws
- X – Spring
- Y – Clutch
- Z – Extension shaft
- AA – Key
- BB – Screw and washers for Ext. shaft
- CC – Extension shaft
- Operator’s manual (not shown)
- Warranty card (not shown)

**⚠WARNING** Read and understand entire contents of this manual before attempting set-up or operation! Failure to comply may cause serious injury.



Figure 1

### Contents – all models

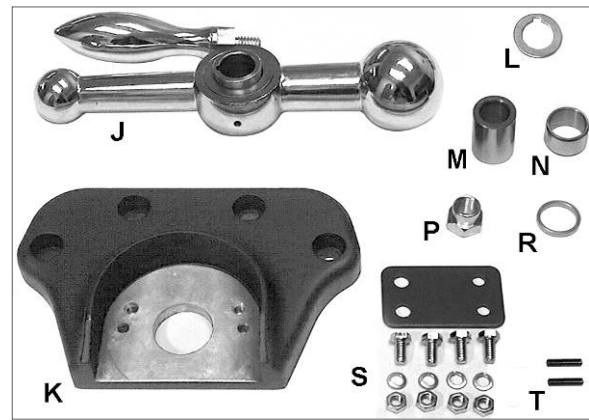

Figure 2  
Accessories – TPFA-X

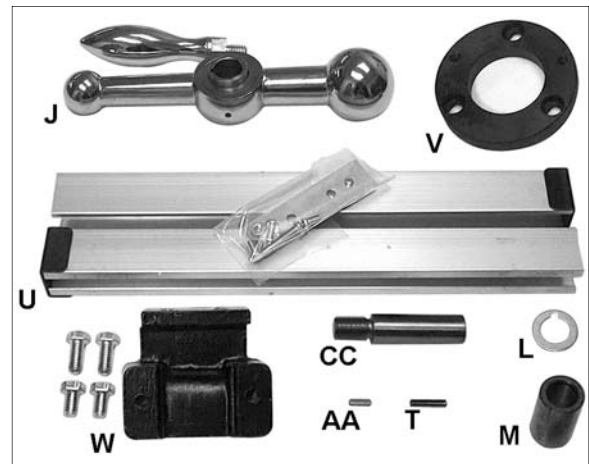

Figure 3  
Accessories – TPFA-Y

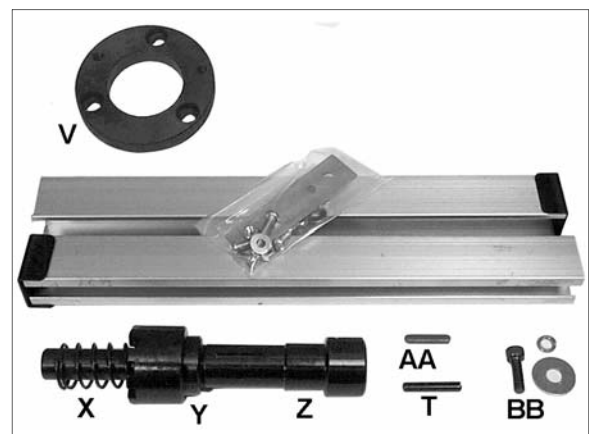

Figure 4  
Accessories – TPFA-Z

### 6.3 X-Axis installation and features

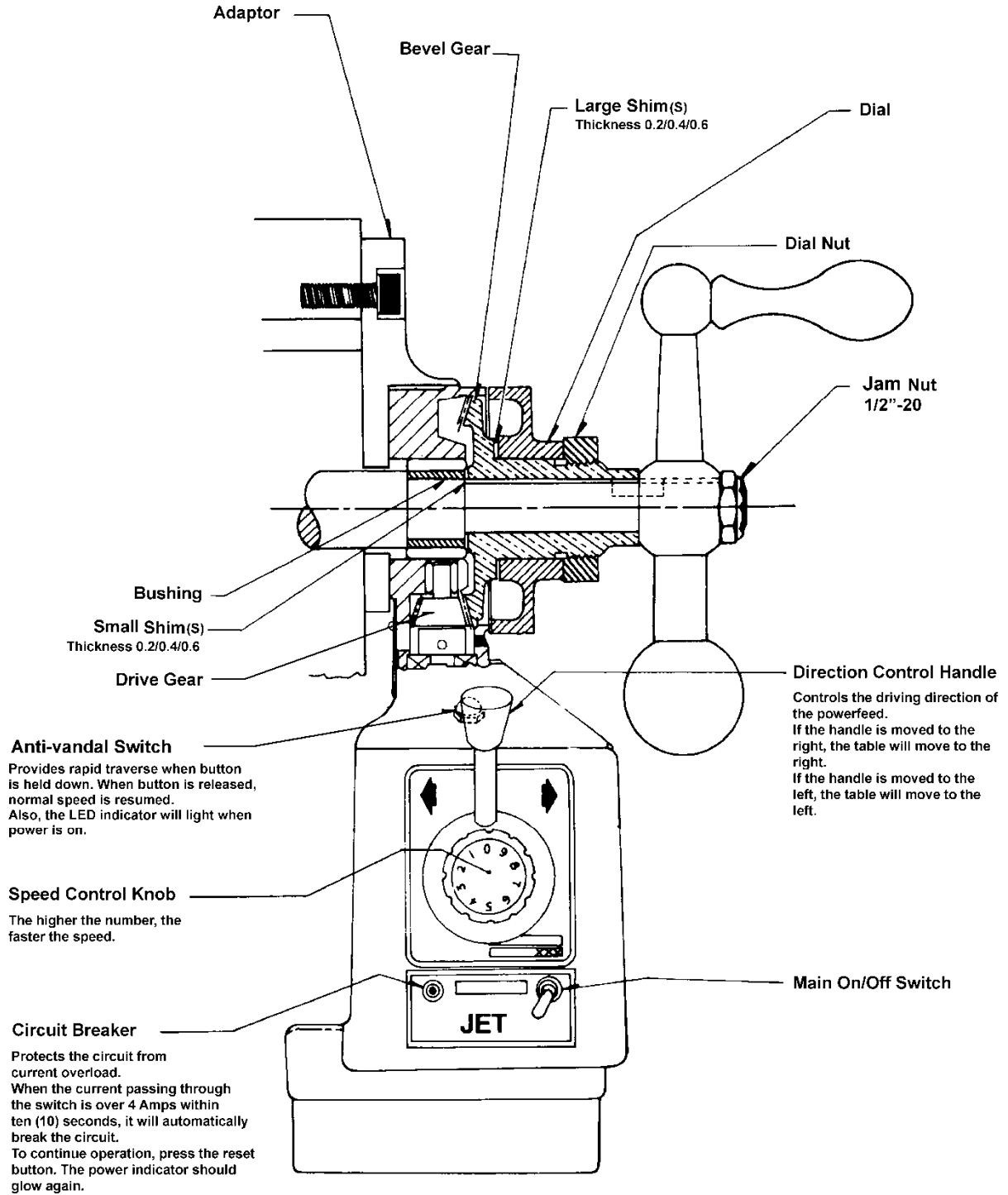

Figure 5



## 6.4 X-Axis installation

Refer to Figure 5:

1. Move table to extreme left-hand position.
2. Remove jam nut, hand crank, dial nut, dial, dial holder, bearing retainer ring, bearing flange, etc.
3. Slide bushing onto lead screw.
4. Slide adaptor onto bushing.
5. Secure adaptor to the end of table with the existing socket head cap screws.
6. Slide powerfeed onto bushing.
7. Secure powerfeed to adaptor using two socket head cap screws provided.

### 6.4.1 Bevel gear

8. Remove protective cap from bevel gear, and slide bevel gear onto lead screw. Manually press and turn bevel gear against drive gear to check for backlash, and make sure they mesh snugly.

Leave the clearance between the two gears as small as possible. If there is some clearance left, place small shims one by one between bearing and bevel gear until the gears are properly fitted. Pack the gears with grease before proceeding.

### 6.4.2 Dial and hand crank

9. After proper gear clearance has been set, slide the dial into position to obtain 0.005" spacing between dial and the face of the powerfeed (this will prevent chips from entering gear train.) Use the two solid and two laminated large shims provided to accomplish the 0.005" spacing. Use further shims if needed.
10. Install dial nut. Place key in shaft and install hand crank. Add washer and locking nut, and tighten locking nut.

### 6.4.3 Limit switch

11. Remove the standard travel stops from your machine. Install the travel stops provided with your powerfeed unit. It is important that these stops be firmly secured in the table track to prevent them from sliding loose and causing the table to travel too far and possibly damage other parts of the machine. It is recommended that you either place the standard stops back in position to block the new travel stops from sliding; or drill a hole behind the table edge and insert a screw through the travel stops from behind.
12. Loosen and remove the two socket head cap screws holding the T-shaped table stop bracket. NOTE: Retain this original bracket should manual table movement ever be needed again.

13. Place the limit switch over the holes and secure with two 3/8 x 1" socket head cap screws provided. See Figure 6. If the actuators are not symmetrical, grind them to obtain the proper position.
14. Secure limit switch cord using the provided clamp. Attach it to the right-hand side of chip scraper with the screw provided. See Figure 6.

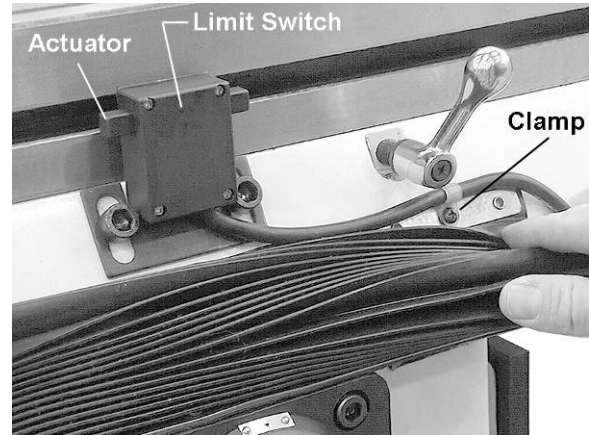

Figure 6

**CAUTION** Never change direction of power feed movement while machine is operating, or damage to gear may result. Turn direction control handle to OFF position and wait for machine to come to a complete stop before reversing direction.

**IMPORTANT:** Installing more than one powerfeed on your machine may reduce table travel. For example, the track assembly for the Y-Axis powerfeed will prohibit full travel of the longitudinal table on which the X-Axis powerfeed is installed. These considerations should be carefully made before installing multiple powerfeeds.

## 6.5 Y-Axis installation

### 6.5.1 Y-Axis track

Drill and tap #10-24 holes in the right side of machine base below the table, for mounting the T-Way Track. See Figure 7.

**Note:** The limit switch mounting bracket provided with your powerfeed is designed for most mounting situations. However, the casting design of your particular machine may require modifications to the bracket system.

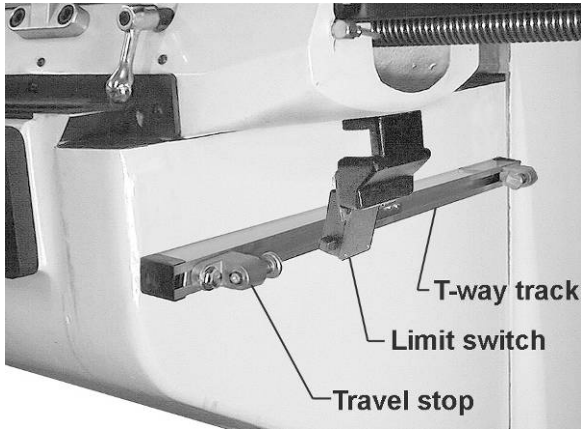
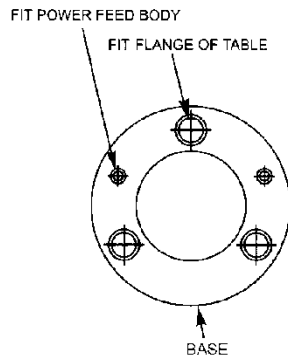
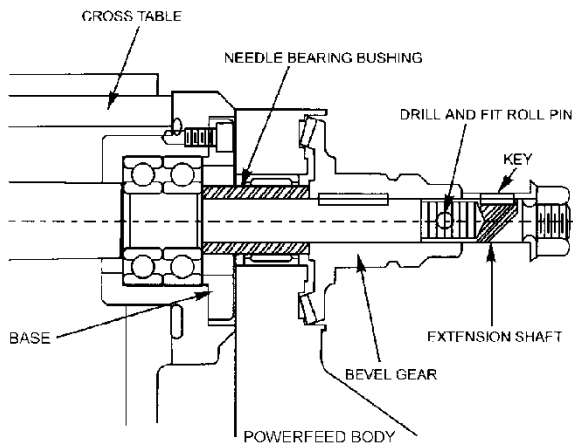

Figure 7

### 6.5.2 Y-Axis powerfeed

Figure 8 shows installation of Y-Axis powerfeed. These instructions are similar (with the exception of the adaptor) to those in section 6.4, steps 1 through 10.

**Important:** Before drilling and inserting the roll pin, make sure all previous steps have been done carefully and correctly.



For ideal installation. You should not modify the cross travel lead screw.

Figure 8

## 6.6 Z-Axis (Knee-lift) installation

### 6.6.1 Z-Axis track

Refer to Figure 9 to install Z-axis track.

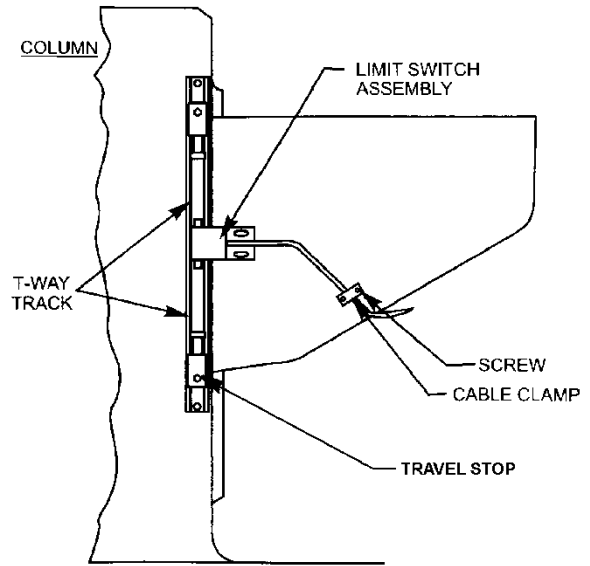

View of lift side of knee and column

Figure 9

## 6.6.2 Z-Axis powerfeed

Refer to Figure 10:

1. Remove hand crank, clutch insert, dial, dial nut, dial holder and bearing flange.
2. Install extension shaft by screwing it onto the table elevating shaft.

### Important:

- Shaft end must be against inner ring of bearing.
- Inner shaft is 16 or 18 threaded UNC.

3. Tighten base to flange, then install powerfeed and tighten it on the flange.
4. Remove protective cover from bevel gear and install bevel gear. (**Note:** Do not install the key yet.) Push and turn the bevel gear by hand to check for backlash. If necessary, add a few shims to obtain proper mesh with the drive gear of the powerfeed unit.

Pack bevel gear with grease. Do not use silicon-type grease. Replace gear then push and turn to check again for backlash.

5. Remove the bevel gear. Install key, replace gear, install dial and tighten dial nut. Add a few shims if the dial is grinding the gear. Important: Pack with grease before installing the bevel gear.
6. Install clutch against bevel gear. Drill through one hole of 5mm diameter, and drive the roll pin into the hole.

**Important:** Be sure you have followed each step carefully and correctly before drilling and installing the roll pin.

Temporarily install the hand crank and rotate in clockwise direction to check for proper shimming and to make sure there is no binding action. Make any needed adjustments before installing roll pin.

7. Install the spring and hand crank, and rotate again to check for proper shimming and smooth movement. Lubricate the opening in the hand crank for smooth movement on the shaft. Then tighten washer and screw at the end of the shaft.

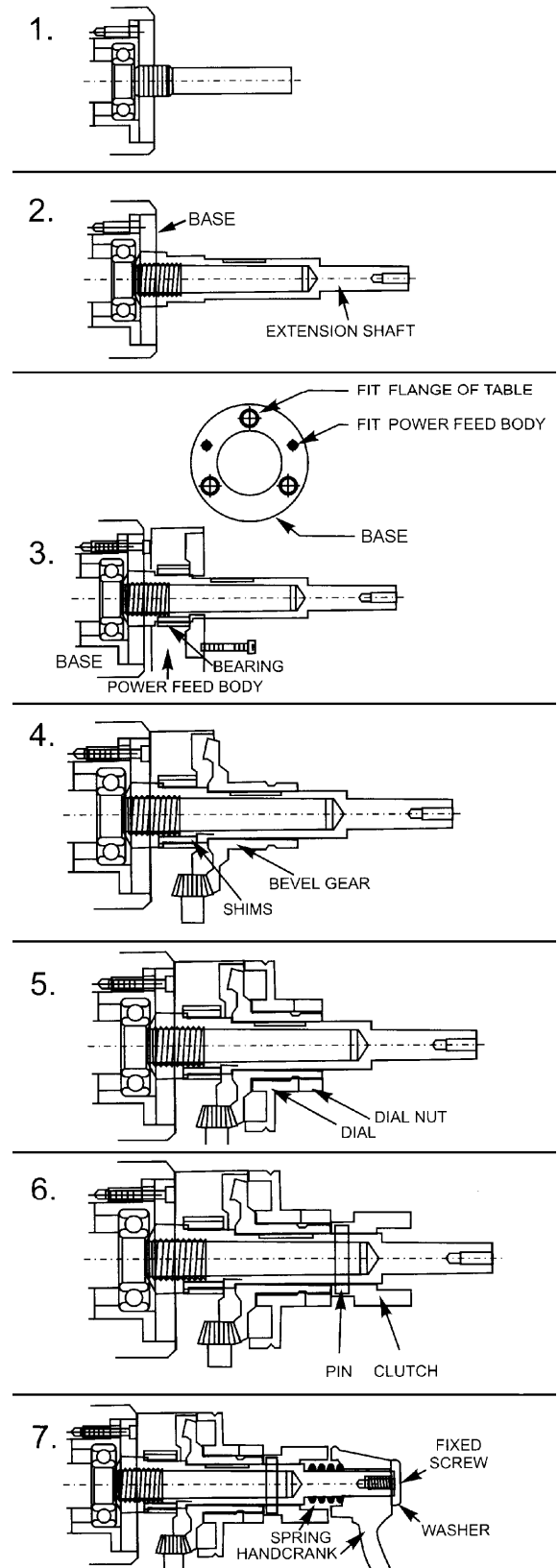

Figure 10

## 6.7 Electrical Connections

**⚠WARNING** Electrical connections must be made by a qualified electrician in compliance with all relevant codes.

The powerfeeder is equipped with a 110 volt motor and a plug designed for use on a circuit with a grounded outlet that looks like the one pictured in **A**, Figure 11.

### 6.7.1 Grounding instructions

#### 1. All Grounded, Cord-connected Tools:

In the event of a malfunction or breakdown, grounding provides a path of least resistance for electric current to reduce the risk of electric shock. This tool is equipped with an electric cord having an equipment-grounding conductor and a grounding plug. The plug must be plugged into a matching outlet that is properly installed and grounded in accordance with all local codes and ordinances.

Do not modify the plug provided - if it will not fit the outlet, have the proper outlet installed by a qualified electrician.

Improper connection of the equipment-grounding conductor can result in a risk of electric shock. The conductor with insulation having an outer surface that is green with or without yellow stripes is the equipment-grounding conductor. If repair or replacement of the electric cord or plug is necessary, do not connect the equipment-grounding conductor to a live terminal.

**⚠WARNING** Check with a qualified electrician or service personnel if the grounding instructions are not completely understood, or if in doubt as to whether the tool is properly grounded. Failure to comply may cause serious or fatal injury.

Use only 3-wire extension cords that have 3-prong grounding plugs and 3-pole receptacles that accept the tool's plug.

Repair or replace damaged or worn cord immediately.

#### 2. Grounded, cord-connected tools intended for use on a supply circuit having a nominal rating less than 150 volts:

This tool is intended for use on a circuit that has an outlet that looks like the one illustrated in **A**, Figure 11. An adapter, shown in **B** and **C**, may be used to connect this plug to a 2-pole receptacle as shown in **C** if a properly grounded outlet is not available. The temporary adapter should be used only until a

properly grounded outlet can be installed by a qualified electrician. *This adapter is not permitted in Canada.* The green-colored rigid ear, lug, and the like, extending from the adapter must be connected to a permanent ground such as a properly grounded outlet box.

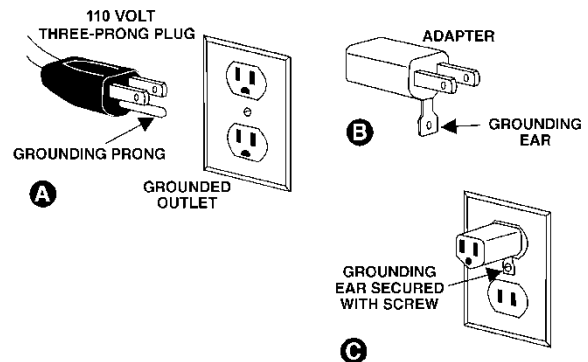

Figure 11

### 6.7.2 Extension Cords

The use of extension cords is discouraged; try to position equipment within reach of the power source. If an extension cord becomes necessary, make sure the cord rating is suitable for the amperage listed on the machine's motor plate. An undersized cord will cause a drop in line voltage resulting in loss of power and overheating.

Use Table 1 as a general guide in choosing the correct size cord. If in doubt, use the next heavier gauge. The smaller the gauge number, the heavier the cord.

Recommended Gauges (AWG) of Extension Cords

Amps	Extension Cord Length *					
	25 feet	50 feet	75 feet	100 feet	150 feet	200 feet
< 5	16	16	16	14	12	12
5 to 8	16	16	14	12	10	NR
8 to 12	14	14	12	10	NR	NR
12 to 15	12	12	10	10	NR	NR
15 to 20	10	10	10	NR	NR	NR
21 to 30	10	NR	NR	NR	NR	NR

\*based on limiting the line voltage drop to 5V at 150% of the rated amperes.

NR: Not Recommended.

Table 1

## 7.0 Troubleshooting

Trouble	Probable Cause	Remedy
Powerfeed will not work; power indicator is not lit.	No incoming power.	Check plug connection.
	Powerfeed switch is off.	Turn switch to ON position.
	Circuit breaker on powerfeed has been tripped.	Reset circuit breaker.
Powerfeed will not work, but power indicator is lit.	Carbon brush is not making proper contact with the armature, or is worn.	Open unit by loosening bottom four screws. Adjust carbon brush for better contact, or replace carbon brush if worn.
	Internal wiring to the printed circuit board is not properly connected.	Inspect and connect any loose wiring.
	Potentiometer connections are loose, or potentiometer is faulty.	First check connections and re-connect if necessary. Replace potentiometer if faulty.
Speed control erratic, or unit only operates at high speed.	Rapid micro switch is stuck, or its position is too high up.	Lightly tap on micro switch to lower it.
	Loose connections or faulty elements.	First inspect connections and re-connect if necessary. If faulty elements, replace as needed.
Breaker keeps tripping during normal operation.	Unit has short circuit.	Inspect limit switch assembly for origin of short circuit. Remove brush cap and inspect armature for short. Measure with an ohmmeter across the carbon brush and the outer cover of powerfeed unit.  Correct any short circuit in the unit.
Unit will move in only one direction.	Limit switch malfunctioning.	Repair or replace limit switch.
The limit switch will not stop the table from traveling farther even after contacting the travel stop.	Limit switch not operating correctly.	Repair or replace limit switch.

## 8.0 Replacement Parts

Replacement parts are listed on the following pages. To order parts or reach our service department, call 1-800-274-6848, Monday through Friday (see our website for business hours, [www.jettools.com](http://www.jettools.com)). Having the Model Number and Serial Number of your machine available when you call will allow us to serve you quickly and accurately.

### 8.1.1 Table Powerfeed – Exploded View

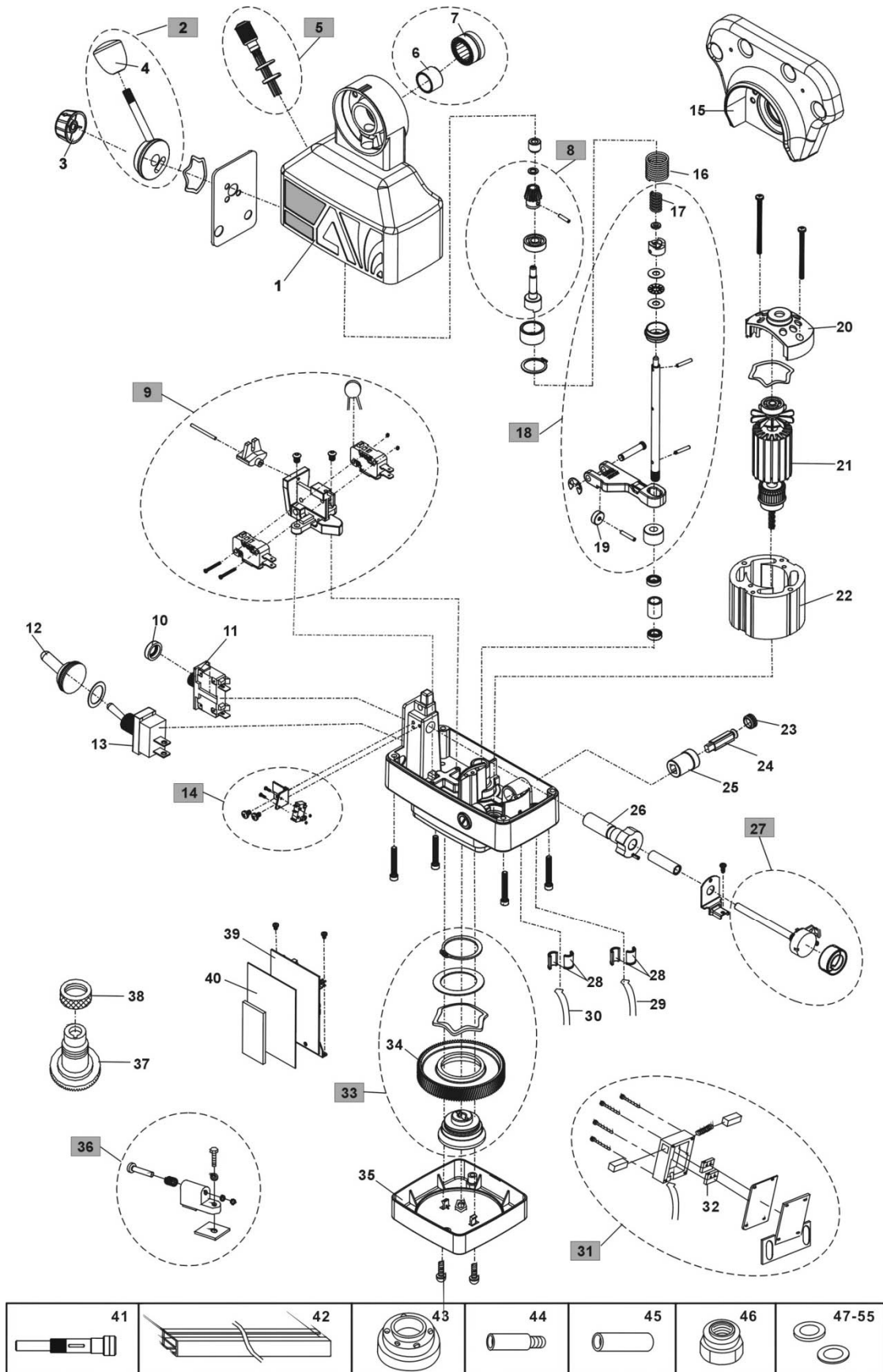

## 8.1.2 Table Powerfeed – Parts List

Index No.	Part No.	Description	Size	Qty
1	TPFA2-PT000-11	Top Housing	TPFA-X	1
2	TPFA2-P01810-11	Control Handle Assembly	180°	1
	P01816-11	Control Handle Assembly (TPFA-Z only)	90°	1
3	TPFA2-P01811-00	Speed Control Knob/Black	ø35.5 x ø29.9 x 19mm	1
4	E0913-00	Handle Knob Assembly/Black	ø31.8 x 33mm	1
5	C0509	Anti-Vandal switch		1
6	A0101B	Inner Ring	ø24 x 16mm	1
7	A0101C	Needle Bearing		1
8	TPFA-PT200	SP Drive Gear Assembly	780 in/lb	1
9	TPFA2-C0501-6V	Direction Switch Assembly		1
10	A0102-01	Cap of Circuit Breaker		1
11	TPFA2-A0102	Circuit Breaker		1
12	E0907-01	Cap of ON/OFF Switch	R13-25A	1
13	TPFA2-E0907	ON/OFF Switch		1
14	C0508	Brake Switch Assembly	6A 125VAC/250AC	1
15	PZ001-13	Adaptor		1
	PZ001-13BH	Adaptor (black hammer color)		1
16	A0112	Spring for Top Housing		1
17	A0301-05	Spring for clutch		1
18	PB300	Forklift Assembly		1
19	P01028	Forklift Ring		2
20	P01082	Armature Mount		1
21	P01907	SP Armature Assembly	780 in/lb	1
22	TPFA2-E0926V	Motor Field		1
23	TPFA2-E0906	Carbon Brush Cap		2
24	TPFA2-E0905	Brush		2
25	TPFA2-P01004	Carbon Brush Holder		2
26	TPFA2-E0902V	250 Cam Assembly		1
27	TPFA2-P01905	Potentiometer Assembly	10K	1
28	E0917	Strain Relief		1
29	TPFA2-E24002	Control Cord	0.75 x 4C x 1.7M	1
30	E23017	Power Cord	0.75 x 3C x 2.7M	1
31	P01910-AL	Limit Switch Assembly		1
32	TPFA2-F1104	Micro Switch		2
33	PB800	Plastic Gear Assembly		1
34	TPFA2-PB801	Plastic Gear		1
35	P01809LS-00	Bottom Cover /Black		1
36	P01916-1	X axis Travel Stop Set		1
	P01916	Y/Z axis Travel Stop Set		1
37	P01017	Bevel Gear (X/Y)	5/8" x 1/8" (780 in /lb)	1
	P01032	Bevel Gear (Z)	22 x 4mm	1
38	TPFA2-A0100-01	Dial Lock Nut	1/4" x 20W	1
39	TPFA2-PB400	Circuit Board Assembly		1
40	TPFA2-E0918V	Circuit Board Insulator		1
41	P01922	Extension Shaft	16T	1
42	A0301-15A	T-Way Track	59.5 cm	1
43	PFB-01A	Steel Stand	29.6 mm	1
44	PFB-16	Extension Shaft	60 mm	1
45	PFB-03	Extension Shaft Ring	40 mm	1
46	PFR-76A	Nut	1/2"-20 x 14.3mm	1
47	TPFA2-A0100-02A	Washer (Optional /not shown)	0.2 x ø34 x Ø45mm	N
48	TPFA2-A0100-02B	Washer (Optional /not shown)	0.4 x ø34 x Ø45mm	N
49	TPFA2-A0100-02C	Washer (Optional /not shown)	0.6 x ø34 x Ø45mm	N
50	TPFA2-A0100-02D	Washer (Optional /not shown)	0.1 x ø34 x Ø45mm	N
51	TPFA2-A0100-04A	Washer (Optional /not shown)	0.2 x ø16 x Ø23.5mm	N
52	TPFA2-A0100-04B	Washer (Optional /not shown)	0.4 x ø16 x Ø23.5mm	N
53	TPFA2-A0100-04C	Washer (Optional /not shown)	0.6 x ø16 x Ø23.5mm	N
54	TPFA2-A0100-04E	Washer (Optional /not shown)	0.1 x ø16 x Ø23.5mm	N
55	TPFA2-A0100-07A	Washer (Optional /not shown)	2 x ø16 x Ø25.4mm	N

# 9.0 Electrical Connections

