



Operating Instructions and Parts Manual 20-inch Gear Head Drill with Powerfeed

Modes J-A2608M-PF2, J-A2608M-PF4



JET
427 New Sanford Road
LaVergne, Tennessee 37086
Ph.: 800-274-6848
www.jettools.com

Part No. M-354030
Revision G 07/2015
Copyright © 2015 JET

1.0 Warranty and service

JET warrants every product it sells against manufacturers' defects. If one of our tools needs service or repair, please contact Technical Service by calling 1-800-274-6846, 8AM to 5PM CST, Monday through Friday.

Warranty Period

The general warranty lasts for the time period specified in the literature included with your product or on the official JET branded website.

- JET products carry a limited warranty which varies in duration based upon the product. (See chart below)
- Accessories carry a limited warranty of one year from the date of receipt.
- Consumable items are defined as expendable parts or accessories expected to become inoperable within a reasonable amount of use and are covered by a 90 day limited warranty against manufacturer's defects.

Who is Covered

This warranty covers only the initial purchaser of the product from the date of delivery.

What is Covered

This warranty covers any defects in workmanship or materials subject to the limitations stated below. This warranty does not cover failures due directly or indirectly to misuse, abuse, negligence or accidents, normal wear-and-tear, improper repair, alterations or lack of maintenance. JET woodworking machinery is designed to be used with Wood. Use of these machines in the processing of metal, plastics, or other materials outside recommended guidelines may void the warranty. The exceptions are acrylics and other natural items that are made specifically for wood turning.

Warranty Limitations

Woodworking products with a Five Year Warranty that are used for commercial or industrial purposes default to a Two Year Warranty. Please contact Technical Service at 1-800-274-6846 for further clarification.

How to Get Technical Support

Please contact Technical Service by calling 1-800-274-6846. **Please note that you will be asked to provide proof of initial purchase when calling.** If a product requires further inspection, the Technical Service representative will explain and assist with any additional action needed. JET has Authorized Service Centers located throughout the United States. For the name of an Authorized Service Center in your area call 1-800-274-6846 or use the Service Center Locator on the JET website.

More Information

JET is constantly adding new products. For complete, up-to-date product information, check with your local distributor or visit the JET website.

How State Law Applies

This warranty gives you specific legal rights, subject to applicable state law.

Limitations on This Warranty

JET LIMITS ALL IMPLIED WARRANTIES TO THE PERIOD OF THE LIMITED WARRANTY FOR EACH PRODUCT. EXCEPT AS STATED HEREIN, ANY IMPLIED WARRANTIES OF MERCHANTABILITY AND FITNESS FOR A PARTICULAR PURPOSE ARE EXCLUDED. SOME STATES DO NOT ALLOW LIMITATIONS ON HOW LONG AN IMPLIED WARRANTY LASTS, SO THE ABOVE LIMITATION MAY NOT APPLY TO YOU.

JET SHALL IN NO EVENT BE LIABLE FOR DEATH, INJURIES TO PERSONS OR PROPERTY, OR FOR INCIDENTAL, CONTINGENT, SPECIAL, OR CONSEQUENTIAL DAMAGES ARISING FROM THE USE OF OUR PRODUCTS. SOME STATES DO NOT ALLOW THE EXCLUSION OR LIMITATION OF INCIDENTAL OR CONSEQUENTIAL DAMAGES, SO THE ABOVE LIMITATION OR EXCLUSION MAY NOT APPLY TO YOU.

JET sells through distributors only. The specifications listed in JET printed materials and on official JET website are given as general information and are not binding. JET reserves the right to effect at any time, without prior notice, those alterations to parts, fittings, and accessory equipment which they may deem necessary for any reason whatsoever. JET® branded products are not sold in Canada by JPW Industries, Inc.

Product Listing with Warranty Period

90 Days – Parts; Consumable items
1 Year – Motors; Machine Accessories
2 Year – Metalworking Machinery; Electric Hoists, Electric Hoist Accessories; Woodworking Machinery used for industrial or commercial purposes
5 Year – Woodworking Machinery
Limited Lifetime – JET Parallel clamps; VOLT Series Electric Hoists; Manual Hoists; Manual Hoist Accessories; Shop Tools; Warehouse & Dock products; Hand Tools; Air Tools

NOTE: JET is a division of JPW Industries, Inc. References in this document to JET also apply to JPW Industries, Inc., or any of its successors in interest to the JET brand.



INNEHÅLL – CONTENT – INHALT

GARANTI – WARRANTY – GARANTIE	2
Skötselinstruktioner – Manual – Bedienungsanleitung	3
Säkerhetsföreskrifter – Safety Instructions – Sicherheitshinweise	3
Generella säkerhetsföreskrifter – General Safety Regulations – Allgemeine Sicherheitsvorschriften.....	4
Vid installation – Installation – Installationsvorschriften	4
Vid användande – During Use – Verwendung	4
Vid service och underhåll – Service and Maintenance – Service und Wartung.....	5
CE-märkning och försäkran om överenskommelse – CE-labelling and Declaration of Compliance – CE-Kennzeichnung und Konformitätserklärung.....	5
Installation – Installation – Installation	6
Uppsättning – Set-up – Aufstellung	6
Inkoppling – Electrical Connection – Anschluss.....	6
Smörjning – Lubrication – Schmierung.....	6
Manöverorgan – Operating Tools – Bedienelemente	7
Inställning av spindelvarvtal – Setting the Spindle Speed – Spindeldrehzahl einstellen.....	7
Handhavande – Handling – Bedienung	7
Val av hastighet – Choice of Speed – Wahl der Drehzahl	7
Verktygsutdrivare – Drill Ejector – Werkzeugaustreiber	7
Växellåda – Drive Gear Box – Getriebe	8
Spindeln – Spindle – Die Spindel	8
Spindelns utbalansering – Counter Balancing the Spindle – Ausgleich der Spindel	9
Motor – Motor – Motor	9
Reparationer – Repairs – Reparaturen	9
Reservdelslista – Spare Parts List – Ersatzteilliste	10

Skötselinstruktioner – Manual – Bedienungsanleitung

<p>Denna skötselinstruktion och reservdelslista är utarbetad för Er som använder, ansvarar eller ger service för denna maskin. Därför bör den som närmast ansvarar för om/eller använder maskinen ha bekväm tillgång till den instruktion och reservdelslista</p> <p>Läs instruktionen innan Ni installerar och startar maskinen. Maskinen är enkelt och robust byggd, men vi kan ej garantera dess perfekta funktion om den behandlas felaktigt. Gör er därför väl förtrogen med maskinen och prova de olika detaljerna i manöversystem och inställningar. Behärskar Ni maskinen kan Ni också utnyttja dess egenskaper fullt ut och få maximal livslängd på alla ingående komponenter.</p> <p>Varje maskins noggrannhet och kapacitet provas vid fabriken. Erfaren personal kontrollerar både mekaniska och elektriska funktioner enligt ett standardiserat program. Vi kan därför garantera att utförandet ligger på en hög och jämn nivå.</p> <p>Följer Ni våra anvisningar och Ert goda omdöme är vi övertygade om att Ni blir belåtna med Er nya maskin. Skulle trots allt problem uppstå, kontakta vår återförsäljare eller oss direkt.</p>	<p>These care instructions and the spare parts lists are prepared for those persons who use, are responsible for, or serve this machine. Therefore, the person who most closely uses or is responsible for the machine should have easy access to these care instructions and spare parts list.</p> <p>Please read the instructions, before you install and start the machine. The machine has a simple and robust design, but we cannot guarantee that it will function perfectly if it is handled improperly. Therefore, be sure to make yourself familiar with the machine and examine the various details of the control system and settings. If you can master the machine, you can also take full advantage of its features and get maximum life out of all the associated components.</p> <p>The accuracy and capacity of each machine is tested at the factory. Experienced personell checks both the mechanical and electrical functions according to a standardized program. We can therefore guarantee a high level of performance.</p> <p>If you follow our instructions and use your best judgement, we are certain that you will be happy with your new machine. Nevertheless, if problems do occur, please contact us directly or contact our retailer.</p>	<p>Diese Bedienungsanleitung und Ersatzteilliste richtet sich an Maschinenbenutzer, Maschinenverantwortliche und Servicepersonal. Maschinenverantwortliche oder Maschinenbenutzer sollten jederzeit auf diese Dokumentation zugreifen können.</p> <p>Lesen Sie diese Anleitung, bevor Sie die Maschine installieren und in Betrieb nehmen. Die Maschine ist einfach und robust konstruiert. Bei unsachgemäßer Behandlung können wir eine einwandfreie Funktionsweise jedoch nicht garantieren. Machen Sie sich daher mit der Maschine vertraut und testen Sie die einzelnen Bedienelemente und Einstellmöglichkeiten. Durch eine umfassende Beherrschung der Maschine können Sie deren Leistungsvermögen voll ausschöpfen und die maximale Lebensdauer aller enthaltenen Bauteile gewährleisten.</p> <p>Genauigkeit und Leistung aller Maschinen werden im Herstellungswerk getestet. Anhand eines standardisierten Ablaufs kontrolliert erfahrenes Personal die mechanischen und elektrischen Funktionen. Auf diese Weise können wir höchste Qualität garantieren.</p> <p>Wenn Sie unsere Anweisungen befolgen und Ihre Erfahrungen nutzen, werden Sie beim Umgang mit dieser Maschine mehr als zufrieden sein. Sollten trotzdem Probleme auftreten, wenden Sie sich an unseren Händler oder direkt an uns.</p>
---	--	--

Säkerhetsföreskrifter – Safety Instructions – Sicherheitshinweise

<p>Rätt använd är denna maskin en av de bästa med avseende på design och säkerhet. Varje maskin som används felaktigt kan emellertid alltid utgöra en olycksrisk. Det är absolut nödvändigt att de som använder maskinen har lärt sig hur man använder den korrekt. De skall läsa och förstå denna manual såväl som alla skyltar som finns på maskinen. Underlåtenhet att följa säkerhetsföreskrifter kan orsaka olyckstillbud.</p>	<p>When used correctly, this is one of the best machines in terms of design and safety. However, any machine that is used improperly can always pose a safety risk. It is absolutely necessary that those persons using the machine have learned how to use it correctly. They should read and understand this material as well all the signs on the machine. Neglecting to follow the safety instructions can cause the risk of an accident.</p>	<p>Bei korrekter Anwendung ist diese Maschine ein Spitzengerät in puncto Design und Sicherheit. Unsachgemäß angewandte Maschinen stellen ein hohes Risiko dar. Es ist unbedingt notwendig, daß das Bedienungs- und Wartungspersonal über die korrekte Funktionsweise der Maschine informiert ist. Jeder Anwender muss vor dem Arbeiten mit der Maschine diese Anleitung sowie alle Maschinenschilder lesen. Eine Nichtbeachtung der Sicherheitshinweise stellt eine potenzielle Gefahrensituation dar.</p>
<p> Varning!</p> <ul style="list-style-type: none"> • Felanvändning av denna maskin kan orsaka allvarliga olyckor. • Maskinen måste installeras, användas och underhållas korrekt. 	<p> Warning!</p> <ul style="list-style-type: none"> • Improper use of this machine can cause serious personal injury. • The machine must be installed and maintained correctly. 	<p> Warnung!</p> <ul style="list-style-type: none"> • Der unsachgemäße Umgang mit dieser Maschine kann schwere Personenschäden verursachen. • Die Maschine muss korrekt installiert und gewartet werden.

Generella säkerhetsföreskrifter – General Safety Regulations – Allgemeine Sicherheitsvorschriften

<p>Alla maskiner med roterande verktyg kan orsaka olyckor. Det är därför viktigt att Du som operatör är medveten om olycksrisken och följer följande föreskrifter.</p> <ul style="list-style-type: none"> • Använd kläder och personlig skyddsutrustning som gör att Du inte kan fastna i det roterande verktyget. • Använd skyddsglasögon om risk för spån- eller kylvätskestänk föreligger eller om lokala regler finns om detta. • Håll rent runt maskinen så att du inte snubblar och faller mot roterande verktyg. • Se till att arbetsstycket är ordentligt låst i bordet. Använd aldrig handen för att hålla arbetsstycket. • Se alltid till att maskinens strömbrytare står i läge 0 när du skall byta verktyg eller rengöra maskinen. Borsta aldrig bort spån under tiden maskinen arbetar. • Använd korrekta verktyg. Se till att rätt varvtal och rätt matning är inställd för verktyget. Försäkra Dig om att verktyget är avsett för arbetet. • Se till att huvud och bord är ordentligt fastlåsta före start. 	<p>All machines with rotating parts can cause accidents. Therefore, it is important that as an operator you are aware of the risk of an accident and follow the guidelines below:</p> <ul style="list-style-type: none"> • Wear clothing and personal safety equipment that cannot get caught in the rotating drilling and tapping tools. • Use eye protection if there is a risk of shavings or coolant splattering, or if there are local regulations in this regard. • Keep the area around the machine clean so that you do not trip and fall against the rotating tool. • Make sure that the work piece is properly clamped to the table. Never use your hands to hold the work piece. • Always make sure that the machine's electric switch is in the 0 position when changing the drilling and tapping tools or cleaning the machine. Never brush shavings away while the machine is working. • Use proper drilling and tapping tools. Make sure that the proper speed and the proper feed rate is set for the drilling and tapping tools. Be sure that the drilling and tapping tools is intended for the work you are doing. • Make sure that heads and tables are properly locked in place before starting. 	<p>Alle Maschinen mit rotierenden Werkzeugen können Unfälle verursachen. Sämtliche Anwender müssen sich dieser Unfallgefahr bewusst sein und die folgenden Hinweise beachten:</p> <ul style="list-style-type: none"> • Tragen Sie nur Arbeitskleidung und persönliche Schutzausrüstung, mit der Sie nicht am rotierenden Werkzeug hängenbleiben können. • Tragen Sie eine Schutzbrille, wenn Späne oder Kühlflüssigkeit herumfliegen oder austreten können bzw. wenn dies durch lokale Sicherheitsbestimmungen vorgeschrieben ist. • Halten Sie den Bereich um die Maschine sauber. Andernfalls besteht Stolpergefahr mit anschließender Berührung rotierender Werkzeuge. • Das Werkstück muss fest auf dem Bohrtisch befestigt sein. Halten Sie Werkstücke niemals mit der Hand fest. • Der Maschinenschalter muss sich in der Stellung "0" befinden, wenn Sie Werkzeuge wechseln oder die Maschine reinigen. Bürsten Sie niemals Späne ab, während die Maschine in Betrieb ist. • Setzen Sie die korrekten Werkzeuge ein. Achten Sie darauf, daß für das Werkzeug die richtige Drehzahl und der richtige Vorschub eingestellt sind. Vergewissern Sie sich, daß das Werkzeug für die jeweilige Verwendung vorgesehen ist. • Achten Sie darauf, daß Bohrkopf und Bohrtisch vor Arbeitsbeginn fest verriegelt sind.
---	--	---

Vid installation – Installation – Installationsvorschriften

<ul style="list-style-type: none"> • Undvik att installera maskinen i fuktig, smutsig eller dåligt belyst miljö. • Försäkra Er om att maskinen har alla nödvändiga skydd. • Elektriska installationer skall utföras av behörig elektriker. • Försäkra Er om att maskinen är stadigt uppställd eller förankrad. 	<ul style="list-style-type: none"> • Avoid installing the machine in a humid, dirty or badly illuminated environment. • Be sure that the machine possesses all necessary protections. • Electric installations have to be executed by a qualified electrician. • Be sure that the machine is steadily put up and positioned. 	<ul style="list-style-type: none"> • Die Maschine sollte nicht in feuchten, schmutzigen und/oder schlecht beleuchteten Räumen aufgestellt werden. • Die Schutzvorschriften müssen absolut beachtet werden. • Der elektrische Anschluss muss von einem Fachmann durchgeführt werden. • Die Maschine muss mit einer Maschinen-Wasserwaage ordentlich ausgerichtet sein.
--	--	---

Vid användande – During Use – Verwendung

<ul style="list-style-type: none"> • Använd aldrig maskinen om den saknar nödvändiga skydd. • Följ gängse regler för maskin användning avseende personlig skyddsutrustning. • Undvik om möjligt att använda arbetshandskar. • Arbeta inte i maskinen med löst sittande klädsel eller smycken. Använd hårnät om nödvändigt. • Sträck Dig aldrig över maskinen när den är igång. • Lämna aldrig maskinen påslagen. • Stoppa alltid maskinen när den inte 	<ul style="list-style-type: none"> • Never use the machine if it is missing the necessary protection. • Follow the current regulations for using the machine in terms of personal safety equipment. • As far as possible, avoid using working gloves. • Do not work with the machine with loose clothing or jewelry. Use a hair net if necessary. • Never stretch over the machine when it is running. • Never leave the machine turned on. • Always stop the machine when not 	<ul style="list-style-type: none"> • Verwenden Sie die Maschine nur, wenn alle erforderlichen Schutzvorrichtungen vorhanden sind. • Befolgen Sie beim Umgang mit der Maschine die allgemeingültigen Regeln zur persönlichen Schutzausrüstung. • Soweit möglich, keine Arbeitshandschuhe verwenden. • Arbeiten Sie nicht an der Maschine mit loser Bekleidung oder Schmuck. Falls erforderlich, tragen Sie ein Haarnetz. • Beugen Sie sich nie über eine im
---	---	---

<p>används.</p> <ul style="list-style-type: none"> Använd borrhskydd. Borrhskydd levereras bara till maskiner med CE-märkning. Vid byte av verktyg trycks borrhskyddet uppåt och viks åt sidan. 	<p>being used.</p> <ul style="list-style-type: none"> Use drilling protection. Drilling protection is only supplied for machines with the CE-label. When changing the drilling and tapping tools, the drilling shield is pushed upward and bent to the side. 	<p>Betrieb befindliche Maschine</p> <ul style="list-style-type: none"> Lassen Sie die Maschine nie unbeaufsichtigt laufen. Halten Sie die Maschine stets an, wenn Sie nicht benutzt wird. Verwenden Sie einen Bohrschutz. Ein Bohrschutz wird nur mit Maschinen ausgeliefert, die eine CE-Kennzeichnung tragen. Beim Werkzeugwechsel drücken Sie den Bohrschutz nach oben und klappen ihn zur Seite.
--	---	---



Bild 1. Borrhskydd – Picture 1. Drill guard – Abb. 1. Bohrschutz

Vid service och underhåll – Service and Maintenance – Service und Wartung		
<ul style="list-style-type: none"> Se alltid till att spänningen till maskinen är frånslagen. Följ alltid instruktionerna i denna manual. Modifiera aldrig maskinen utan att rådfråga vår återförsäljare. 	<ul style="list-style-type: none"> Always make sure that the power to the machine is off. Always follow the instructions in this manual. Never alter the machine without consulting our retail dealer. 	<ul style="list-style-type: none"> Trennen Sie die Maschine stets von der Stromquelle, bevor Sie Arbeiten an ihr ausführen. Befolgen Sie stets die Anweisungen in diesem Dokument. Nehmen Sie ohne vorherige Rücksprache mit unserem Händler keinerlei Änderungen an der Maschine vor.

CE-märkning och försäkran om överenskommelse – CE-labelling and Declaration of Compliance – CE-Kennzeichnung und Konformitätserklärung		
<p>Om denna maskin är CE-märkt betyder det att den vid leverans uppfyller de tillämpliga "Väsentliga Hälso- och Säkerhetskrav" som anges i EU:s så kallade Maskinsäkerhetsdirektiv. Om förändringar görs som påverkar maskinens säkerhet ansvarar den som utför förändringarna för dessa.</p> <p>Som bevis på att kraven uppfylles medlevereras en EU-försäkran om överenskommelse, utfärdad av Machinery Scandinavia AB för varje enskild maskin. Denna EU-försäkran omfattar också tillbehör tillverkade av Machinery Scandinavia AB. Dokumentationen är en värdehandling som skall bevaras väl och som alltid ska medfölja maskinen vid försäljning.</p> <p>Om maskinen används för andra ändamål eller med andra tillbehör än som anges i denna instruktion måste säkerheten säkerställas i varje enskilt fall. Ansva-</p>	<p>If this machine has a CE-label, then it upon delivery fulfils the appropriate "Critical Health and Safety Requirements" specified in the EU's so-called Machine Safety Directive. If changes are made which affect the machine's safety, the person making these changes is responsible for them.</p> <p>As proof that the requirements have been met, an EU Declaration of Compliance is delivered with each machine, prepared by Machinery Scandinavia AB. This EU declaration also covers accessories manufactured by Machinery Scandinavia AB. The documentation is valuable and should be properly preserved and should always accompany the machine when sold.</p> <p>If the machine is used for other purposes or with accessories other than what is specified in these instructions, its safety must be ensured in each individual case.</p>	<p>Wenn diese Maschine eine CE-Kennzeichnung besitzt, dann erfüllt Sie bei ihrer Lieferung die "grundlegenden Gesundheits- und Sicherheitsvorgaben" der EU-Richtlinie zur Maschinensicherheit. Wenn Änderungen vorgenommen werden, die die Maschinensicherheit beeinträchtigen, trägt derjenige die Verantwortung, der diese Änderungen ausgeführt hat.</p> <p>Als Beleg dafür, daß alle Vorgaben erfüllt wurden, liegt jeder Maschine eine von Machinery Scandinavia AB ausgefertigte EU-Konformitätserklärung bei. Diese EU-Erklärung umfasst ebenfalls Zubehör, das von Machinery Scandinavia AB hergestellt wurde. Diese Dokumentation stellt eine wichtige Urkunde dar, die gut aufzubewahren und der Maschine bei einem Verkauf stets beizulegen ist.</p> <p>Wenn die Maschine zu anderen Zwecken oder mit anderem Zubehör eingesetzt</p>

rig är den som utför den och kan i vissa fall kräva ny CE-märkning och utfärdande av ny EU-försäkran om överenskomst.	Responsibility lies with the person who operates it, and in certain cases, a new CE-label or new EU Declaration of Compliance may be required.	wird als in dieser Anleitung angegeben, ist die Sicherheit in jedem einzelnen Fall zu gewährleisten. Verantwortlich dafür ist die jeweils ausführende Person. In bestimmten Fällen kann eine neue CE-Kennzeichnung und die Ausfertigung einer neuen EU-Konformitätserklärung erforderlich sein.
---	--	---

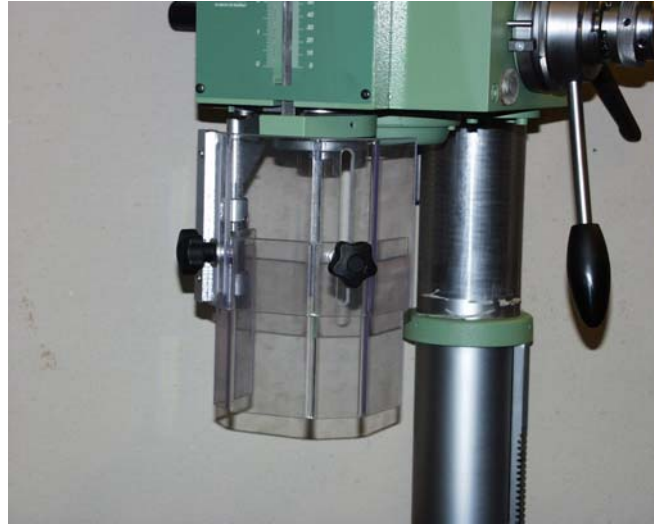
Installation – Installation – Installation

Uppsättning – Set-up – Aufstellung

<ul style="list-style-type: none"> • Kontrollera att maskinen inte har skadats under transporten. Om så är fallet kontakta omedelbart vår återförsäljare. • Placera maskinen på ett stabilt underlag. Förankra maskinen med bultar om så erfordras. Fotplattan understöds vid fastdragning av fästbultarna, så att den inte erhåller någon skadlig spänning. • Tvätta bort det rostskyddsmedel som maskinen är behandlad med vid leverans. Använd inte för mycket lösningsmedel eftersom lösningsmedel även löser infettning. Tvätta verktygsinfästningen i borrarspindeln speciellt nog. 	<ul style="list-style-type: none"> • Check that the machine has not been damaged during transport. If this is the case, contact our retail dealer immediately. • Place the machine on a steady foundation. Anchor the machine with bolts if required. Place a protection between the ground plate and the bolts, in order to avoid dangerous voltage. • Clean the machine from the rust-protection the machine is treated with during delivery. Do not use too much solvent, since the solvent can also remove the lubrication. 	<ul style="list-style-type: none"> • Kontrollieren Sie die Maschine auf eventuelle Transportschäden. Setzen Sie sich bei Beschädigungen umgehend mit unserem Händler in Verbindung. • Stellen Sie die Maschine auf einer stabilen Unterlage auf. Falls erforderlich, verankern Sie die Maschine mit Bolzen. Zwischen der Grundplatte und den Bolzen sollte ein Schutz installiert werden, um schädliche Spannungen zu vermeiden. • Waschen Sie das Rostschutzmittel ab, mit dem die Maschine im Lieferzustand behandelt ist. Setzen Sie dabei nicht zu viel Lösungsmittel ein, da auf diese Weise die Schmierung entfernt werden kann. Reinigen Sie die Werkzeughalterung in der Bohrspindel besonders gründlich.
--	--	--

Inkoppling – Electrical Connection – Anschluss

<p>Inkopplingen skall alltid utföras av behörig elektriker.</p> <ul style="list-style-type: none"> • Kontrollera att rätt spänning tillförs maskinen. • Observera jordskruven! (se bifogat kopplingsschema) Koppla in direkt på huvudmotorns motorskydd eller, när det gäller flerspindliga maskiner, i en kopplingsdosa. • Kontrollera att borrarspindeln har rätt rotationsriktning. 	<p>Electrical installations should always be performed by authorized electricians.</p> <ul style="list-style-type: none"> • Make sure that the correct voltage is supplied to the machine. • Note the earth screw! (according to enclosed circuitry diagram). Connect the electricity directly on the main motor's automatic circuit breaker. • Make sure that the drilling spindle has the correct rotation direction. 	<p>Der Anschluss ist stets von einem ausgebildeten Elektriker vorzunehmen.</p> <ul style="list-style-type: none"> • Kontrollieren Sie, ob die Maschine mit der richtigen Spannung versorgt wird. • Beachten Sie die Erdungsschraube! (siehe beiliegender Schaltplan). Schließen Sie den Motorschutz des Hauptmotors direkt oder bei mehrspindligen Maschinen an einer Anschlussdose an. • Überprüfen Sie, ob die Drehrichtung der Bohrspindel korrekt ist.
--	---	--

Smörjning – Lubrication – Schmierung

<p>Samtliga kullager och kuggjul är infettade från fabrik.</p> <p>Växelhuset skall ej fyllas med olja. Alltför riklig smörjning bör undvikas, enär oljan kan tränga ned i motorn och skada isolationen hos denna.</p> <ul style="list-style-type: none"> • Kontrollera växellådans infettning efter några års drift. • Smörj matningsväxellådan (för maskiner med sådan) och övriga rörliga delar genom smörjkopparna. • Matningsväxellådans snäckväxel ligger i ett oljebad. Fyll på olja genom påfyllningshålet till mitten på nivåglasat (ca 0,3 liter). Lämplig olja bör en viskositet av 11 °E vid 50 °C. Se separat oljerekommendation. <p>OBS! Maskiner med automatisk matning levereras utan olja i matningsväxellådan.</p>	<p>All ball bearings and gear wheels are lubricated at the factory.</p> <p>The gear box should not be filled with oil. Avoid too much lubrication, as oil can drip down into the motor and damage the insulation.</p> <ul style="list-style-type: none"> • Check the gear box's lubrication after several years of use. • Lubricate the feed gearbox (for machines equipped with one) and other movable parts by using the lubricating cups. • The feed gear box's worm gear sits in an oil bath. Add oil via the filling hole up to the middle of the level indicator (approx. 0.3 liters). Proper oil should have a viscosity of 11 °E at 50 °C. See the separate oil recommendations. <p>NOTE! Machines with automatic feed are not supplied with oil in the feed gearbox.</p>	<p>Alle Kugellager und Zahnräder sind ab Werk geschmiert.</p> <p>Das Getriebe darf nicht mit Öl gefüllt werden. Allzu reichliche Schmierung vermeiden, da sonst Öl in den Motor eindringt und die Wickelung zerstört.</p> <ul style="list-style-type: none"> • Kontrollieren Sie die Schmierung des Getriebes nach mehreren Betriebsjahren. • Schmieren Sie das Vorschubgetriebe (falls vorhanden) sowie alle anderen beweglichen Teile über die Schmierbuchsen. • Das Schneckengetriebe des Vorschubgetriebes liegt in einem Ölbad. Füllen Sie durch das Füllloch Öl bis zur Mitte des Schauglases auf (ca. 0,3 l). Geeignetes Öl sollte eine Viskosität von 11°E bei 50 °C aufweisen (siehe separate Ölempfehlung). <p>HINWEIS! Maschinen mit automatischem Vorschub werden ohne Öl im Vorschubgetriebe geliefert.</p>
--	--	---

Manöverorgan – Operating Tools – Bedienelemente		
Inställning av spindelvarvtal – Setting the Spindle Speed – Spindeldrehzahl einstellen		
<p>Varvtalen ställs in med de två växelhandtagen på spindelhusets vänstra sida. Ställ in enligt skylten på framsidan. Maskinen måste stå still när växling görs.</p> <p>Skulle någon växel vara svår att få i läge, rotera spindelns nos för hand.</p>	<p>The rotation speed is set using the two gear levers on the left side of the spindle case. Set them according to the sign on the front side. The machine must be at a stand still to make the switch.</p> <p>If any of the gears are difficult to get into position, rotate the spindle nose manually.</p> <p>Be sure that the automatic circuit breaker is off.</p>	<p>Die Drehzahl wird mittels der beiden Griffe auf der linken Seite des Spindelgehäuses eingestellt. Richten Sie sich dabei nach dem Schild auf der Vorderseite. Zum Wechseln der Drehzahl muss die Maschine still stehen.</p> <p>Wenn eine Einstellung nur schwer vorgenommen werden kann, drehen Sie die Spindelns nos per Hand.</p>
Handhavande – Handling – Bedienung		
Val av hastighet – Choice of Speed – Wahl der Drehzahl		
<p>Maskinen är försedd med en 2-hastighetsmotor.</p> <ul style="list-style-type: none"> • Ställ in önskat läge (1 eller 2) med vredet • Välj spindelns hastighet med de två växelhandtagen på maskinens vänstra sida. Se skylten på maskinens framsida. • Roter spindelns nos för hand om någon växel är svår att få i läge. <p>OBS! Maskinen får inte växlas under gång.</p>	<p>The machine is equipped with a 2-speed motor.</p> <ul style="list-style-type: none"> • Set the desired position (1 or 2) with the dial • Select the spindle speed, using the two gear levers on the left side of the machine. See the sign on the front side of the machine. • If any of the gears are difficult to get into position, rotate the spindle nose manually. <p>NOTE! The machine cannot be shifted during operations.</p>	<p>Die Maschine ist mit einem Motor mit zweifacher Drehzahlumschaltung ausgestattet.</p> <ul style="list-style-type: none"> • Stellen Sie per Schalter die gewünschte Drehzahl ein (1 oder 2). • Die Spindelgeschwindigkeit wird mit Hilfe der beiden Griffe auf der linken Maschinenseite eingestellt. Richten Sie sich dabei nach dem Schild auf der Vorderseite. • Wenn eine Einstellung nur schwer vorgenommen werden kann, drehen Sie die Spindelns nos per Hand. <p>HINWEIS! Die Drehzahl darf während des Betriebs nicht gewechselt werden.</p>
Verktygsutdrivare – Drill Ejector – Werkzeugaustreiber		
<p>Maskinen är utrustad med automatisk verktygsutdrivare. Mellan spindelhusets nos och spindelhuset finns en spärr som gör att spindelns nos aldrig går upp i sitt övre läge.</p> <ol style="list-style-type: none"> 1. Se till att klockopplingen för manuell matning är införd. 2. Vik ut spärren och för spindelhuset till sitt övre läge med nedmatningshandtaget. Därvid stöts verktyget ut. 3. Vik tillbaka spärren. <p>Verktyget kan ha fastnat hårt i spindelns nos ex genom hårt borrartryck och värmeförändring i spindelns nos. I sådant läge rekommenderar vi att en utdrivningskil används i stället för den automatiska verktygsutdrivaren.</p> <p>OBS! Se alltid till att verktygens tunga är väl rengjord. Därmed undviks onödigt slitage på borrarspindelns infästning och att verktyget fastnar i spindelns nos.</p>	<p>The machine is equipped with an automatic drill ejector. Between the nose of the spindle sleeve and the spindle case, there is a stopper that prevents the spindle from ever reaching its upper position.</p> <ol style="list-style-type: none"> 1. Make sure that the claw coupling for manual feed is inserted. 2. Bend out the stopper and bring the spindle sleeve to its upper position with the lower feed lever. The boring tool should be pushed out. 3. Bend the stopper back. <p>The boring tool may become stuck in the spindle, e.g. via hard drilling pressure and heat changes in the spindle. In this case, we recommend using an expeller wedge instead of the automatic drill ejector.</p> <p>NOTE! Always be sure that the boring tool's tongue is well-cleaned. This avoids unnecessary wear and tear of the drilling spindle and/or the boring tool getting caught in the spindle.</p>	<p>Die Maschine ist mit einem automatischen Werkzeugaustreiber ausgestattet. Zwischen der Nase der Spindelhülse und dem Spindelgehäuse befindet sich eine Sperre, die verhindert, daß sich die Spindel über ihre obere Stellung hinausbewegt.</p> <ol style="list-style-type: none"> 1. Vergewissern Sie sich, daß die Klauenkupplung für den manuellen Vorschub hineingeschoben ist. 2. Klappen Sie die Sperre nach außen und bewegen Sie die Spindelhülse mit dem Vorschubhandgriff in ihre obere Stellung. Dadurch wird das Werkzeug herausgestoßen. 3. Klappen Sie die Sperre zurück. <p>Durch einen hohen Bohrdruck oder eine Temperaturänderung in der Spindel kann das Werkzeug in der Spindel festsitzen. In diesem Fall empfehlen wir den Einsatz eines Austreibkeils anstelle des automatischen Werkzeugaustreibers.</p> <p>HINWEIS! Achten Sie stets darauf, daß das Werkzeug gründlich gereinigt ist. Dadurch wird ein unnötiger Verschleiß an der Bohrspindelhalterung oder ein Festsitzen des Werkzeugs vermieden.</p>

Växellåda – Drive Gear Box – Getriebe		
<p>Skall växellådan demonteras förfäres enligt följande:</p> <p>De fyra skruvar, som förbinder växellådan med spindelhuset, skruvas bort. Fläktkåpa och fläkt borttages från undersidan av spindelhuset. Med lätta slag på rotoraxeln lossas växellådan, som sedan lyftes bort. Växellådshuset som är delat vertikalt, sammanhålls av 4 st skruvar, som borttages, varefter växellådan kan delas. Axlarna kan då lyftas ur och bli tillgängliga för vidare demontering.</p> <p>Vid hopläggning av växellådan tillses att växelföraren kommer i spåret på kopplingen. Då växellådan sättes på spindelhuset, kontrolleras att kilarna i spindeln sitter på plats och att kilspåren i utgående axeln kommer mitt för kilarna.</p>	<p>When it is necessary to disassemble the drive gear box:</p> <p>Remove the four screws, which connect the drive gear box to the quill housing. Then take away the fan cover and the fan from the quill housing. By knocking slightly on the rotor shaft, the drive gear box can be removed. The gear box casting, consisting of two halves, can be taken apart by loosening the four screws. All shafts can now be taken out for further disassembling.</p> <p>When re-assembling the drive gear box, check that the shift pin fits properly into the groove of the clutch. When re-placing the drive gear box on the quill housing, it must be checked that the driving keys in the spindle are in place and that they will fit properly into the corresponding key ways on the gear box output shaft.</p>	<p>Muss das Getriebe demontiert werden, verfähre man folgendermaßen:</p> <p>Die vier Schrauben, die das Getriebe mit dem Spindelgehäuse verbinden, werden entfernt. Ventilatordeckel und Ventilator werden von der Unterseite des Spindelgehäuses abgenommen. Mit leichten Schlägen auf die Motorwelle wird das Getriebe gelöst und danach abgenommen. Das vertikal geteilte Getriebegehäuse wird mit vier Schrauben zusammengehalten. Werden diese entfernt, kann das Getriebe geöffnet werden. Die Wellen können dann herausgehoben werden und sind zur weiteren Demontage zugänglich.</p> <p>Beim Zusammenbau des Getriebes muss beachtet werden, dass die Schaltsteine in die Nuten der Kupplungen fassen. Beim Aufsetzen des Getriebes auf das Spindelgehäuse muss beachtet werden, dass die Keilnuten in der herausragenden Welle mitten über die Keile kommen.</p>
Spindeln – Spindle – Die Spindel		
<p>Spindeln är lagrad i spindelhylsan med ett koniskt rulllager nedtill och ett radialkullager upptill. För justering av lagerglappet finns upptill på spindeln en mutter. Den blir åtkomlig på följande sätt:</p> <ol style="list-style-type: none"> 1. Montera av djupmättstången från spindeloket och mata ur spindeln. 2. Håll hela tiden i borrhjulet så att den ej skadas. 3. Låt den nu uppspända returfjädern återgå sakta till ospänt läge. 4. Justera glappet för spindellagringen, var noga med att känna efter så att det inte går tungt. 5. Montera i spindeln i huset igen genom att förspänna returfjädern med nedmatningen ca: 2 varv på matningsaxeln och för upp spindeln. 6. Känn efter att båda kilarna styr in i spindelförlängarens spår och att kuggarna på mataraxeln griper in i kuggstången på spindelhylsan. 7. Låt spindeln återgå och kontrollera matningshandtagens läge, justeras med omflyttning av läge vid uppsläpp av spindel. Återmontera djupmättstången. 	<p>The spindle is journalled in the quill by a taper roller bearing at the bottom and by a radial ball bearing at the top. At the top end of the spindle, there is a nut, with which the play in the taper bearing can be adjusted. This nut can be reached, when the quill is removed from the machine as follows:</p> <ol style="list-style-type: none"> 1. Remove the depth stop rod and feed out the complete quill. 2. Hold the quill, so that it doesn't fall out and gets damaged. 3. Loosen the spring pressure by letting the handle slowly return. 4. Adjust the play at the top end of the quill. Make sure it doesn't turn heavily. 5. Re-assemble the quill by turning one of the handles in the feed shaft about two turns for counter balancing the quill, and put back the quill. 6. Make sure the keys on the spindle coincide with the key ways in the spindle shaft and that the teeth of the feed shaft get the grip of the quill feed rack. 7. Let the quill return to the top position, check the position of the feed handles, and adjust by the feed shaft teeth grip another rack position. Re-assemble the depth stop rod. 	<p>Die Spindel ist unten in einem Kegelrollenlager und oben in einem Rollenlager in der Pinole gelagert. Zur Einstellung des Lagerspieltes befindet sich oben an der Spindel eine Mutter. Diese wird zugänglich, nachdem die Pinole auf folgende Weise aus dem Spindelgehäuse genommen wurde:</p> <ol style="list-style-type: none"> 1. Die Tiefenmassstange entfernen und die Pinole aus dem Bohrkopf austreiben. 2. Eine Hand unter die Pinole halten, damit die Pinole nicht herausfällt und beschädigt wird, 3. Die Rückholfeder langsam wieder zurückkehren lassen. 4. Das Spiel des Lagers am Ende der Pinole justieren, so dass sie gut umläuft. 5. Die Pinole in das Gehäuse wie folgt zurücksetzen: Die Vorschubwelle zweimal drehen, um die Rückholfeder wieder aufzuspannen und dann die Spindel zurücksetzen. 6. Bitte beachten, dass die Keile der Spindel wieder gut in die Nuten der Spindelverlängerung fassen, und dass die Zähne der Vorschubwelle gut in die Zahnstange der Pinole eingreifen. 7. Die Pinole wieder zurückkehren lassen und die Position der Handgriffe in einer anderen Position der Zahnstange justieren. Die Tiefenmassstange wieder zurück montieren.

Spindelns utbalansering – Counter Balancing the Spindle – Ausgleich der Spindel		
<p>Fjäderhuset för spindelns utbalansering borttages på följande sätt.</p> <p>Demontera elboxen från spindelhuset och låt det hänga vid sidan om.</p> <p>Lossa skruven, som låser fast fjäderhuset på undersidan av spindelhuset.</p> <p>Låt fjäderhuset vrida sig, så att fjädern kommer i viloläge. Huset med isittande fjäder kan nu tas bort.</p> <p>Vid montering tryckes fjäderhuset med fjädern in på sin plats i slitsen på axeln.</p> <p>Se till att fasen i slitsen går mot första utgående böj på fjädern, vrid sedan moturs till önskad utbalansering erhållits på spindeln. Sedan låses huset fast med skruven på spindelhusets undersida.</p>	<p>The spring housing for counter balancing of the spindle is removed as follow:</p> <p>Unmount the electric box from the spindle house and put aside (you do not have to disconnect the cables).</p> <p>Undo the screw, which keeps the spring housing to the spindle housing.</p> <p>Let the spring housing turn to release the pressure on the spring. The housing with included spring can now be removed.</p> <p>When assembling, press the spring housing into the slot on the shaft.</p> <p>Make sure that the slot goes against the first bending on the spring. Turn in counter-clockwise until desired counter balancing is reached and then lock the spindle housing with the screw.</p>	<p>Das Federgehäuse zum Ausgleich der Spindel wird auf folgende Weise entfernt:</p> <p>Lösen Sie den Elektrokasten vom Spindelgehäuse und lassen Sie den Kasten an der Seite hängen (die Kabel brauchen nicht gelöst werden).</p> <p>Die Schraube lockern, die das Federgehäuse am Spindelgehäuse festhält.</p> <p>Das Federgehäuse sich drehen lassen, bis die Feder entspannt.</p> <p>Das Gehäuse mit darin liegender Feder kann nun abgenommen werden.</p> <p>Beim Zusammenbau das Federgehäuse in den Schlitz der Welle drücken.</p> <p>Die Abschrägung des Schlitzes gegen den Uhrzeigersinn drehen, bis der gewünschte Ausgleich der Spindel erreicht ist und dann das Gehäuse mit der Schraube an das Spindelgehäuse festschrauben.</p>
Motor – Motor – Motor		
<p>Om motorn skall bytas på grund av motorfel, tillgår detta på följande sätt:</p> <p>Maskinen göres strömlös, och motorledningarna lossas från motorn.</p> <p>Skruva loss flänsen och demontera motor med fläns från borrhuvudet.</p> <p>Skruva loss och byt motor på flänsen, montera också över den elastiska kopplingen på den nya motorn.</p> <p>Återmontera allt i omvänd ordning och anslut ledningarna igen.</p>	<p>If it is necessary to remove the motor, proceed as follow:</p> <p>Disconnect the machine and remove the wires from the motor.</p> <p>Unscrew the flange and dismantle the motor with flange from the drill head.</p> <p>Unscrew and change the motor on the flange.</p> <p>Assemble the elastic clutch on the new motor. Re-assemble everything in reverse order and connect the wires again.</p>	<p>Bei Motorschäden den Motor wie folgt austauschen:</p> <p>Die Maschine abschalten und die Leitungen vom Motor trennen.</p> <p>Die Flansch losschrauben und den Motor mit Flansch vom Bohrkopf abnehmen.</p> <p>Den Motor der Flansch losschrauben und austauschen.</p> <p>Die elastische Kupplung an den neuen Motor montieren.</p> <p>Alles umgekehrt wiederherstellen und die Leitungen wieder anschließen.</p>
Reparationer – Repairs – Reparaturen		
<p>Vid rätt handhavande, underhåll och skötsel är inga reparationer förutom eventuellt byte av fjäderhus nödvändiga.</p> <p>Skulle ändå reparationer bli nödvändiga ger reservdelsbilderna god vägledning. Uppstår osäkerhet, kontakta vår återförsäljare eller vår fabrik.</p>	<p>With proper handling, maintenance and care, no repairs are needed apart from changing the spring case if necessary.</p> <p>Should repairs be necessary, the spare parts pictures can be used as guidelines. If you are uncertain, please contact our retailer or our factory.</p>	<p>Bei vorschriftmäßiger Bedienung, Wartung und Pflege sind neben einem eventuellem Wechsel des Federgehäuses keine Reparaturen erforderlich.</p> <p>Sollte dennoch Reparaturbedarf bestehen, richten Sie sich nach den Ersatzteilabbildungen. Wenden Sie sich bei Unklarheiten an unseren Händler oder unser Werk.</p>

Reservdelslista – Spare Parts List – Ersatzteilliste

Spindelhuvud – Drill head – Bohrkopf.....	11
Växellåda – Gear box – Getriebegehäuse	12
Motoraxel – Engine shaft – Motorwelle	13
2:a axel – 2:nd shaft – 2:e Welle.....	14
3:e axel – 3:rd shaft – 3:e Welle	15
Pelare – Column – Säule.....	16
Pelare bänk – Column bench type drill – Säule Tischbohrmaschine	17
2X08720 – Snäckväxelhus kompl. – Worm gear box compl. – Schneckengetriebegehäuse kompl....	18
Matningsaxel (manuell) – Feed shaft (manual) – Vorschubwelle (manuell).....	19
Matningsaxel (M) – Feed shaft (M) – Vorschubwelle (M)	20
Spindelhylsa – Spindle sleeve – Spindelhülse	21
2X08705 – Ellåda – Electric Box – Elektrokasten	22
Måttskisser – Dimension sketches – Masskizzen	23
Elschema – Electric diagram – Elektrodiagramm.....	26
Oljerekommendationer (M) – Oil recommendations (M) – Öl (M).....	Fel! Bokmärket är inte definierat.

Spindelhuvud – Drill head – Bohrkopf

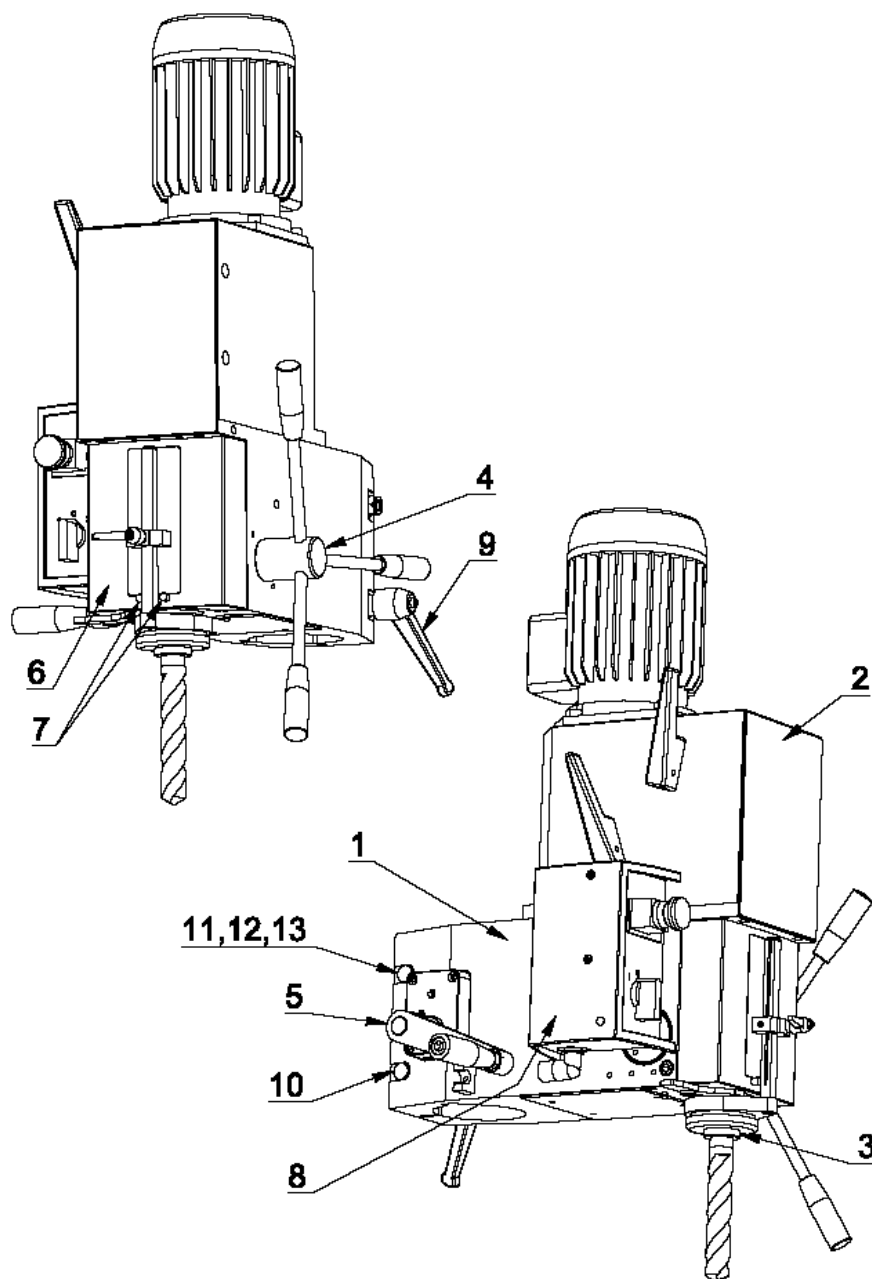

Pos	Art. No.	Benämning	Description	Benennung	Not
1.	2X08770	Spindelhus	Spindle housing	Spindelgehäuse	
2.	2X08774	Växellåda	Gear box	Getriebekasten	
3.	2X08710	Spindelhylsa	Spindle sleeve	Spindelhülse	
4.	2X08752R	Matningsaxel komp.	Feed shaft compl.	Vorschubwelle kompl.	
5.	2X08720-1R	Snäckväxel	Worm gear unit	Schneckenwechsel	
6.	2X08702	Frontkåpa	Front cover	Frontdeckel	
7.	3P01407	Pinne	Pin	Stift	CP 8x36
8.	4U08775	Elboxkåpa	Electric box cover	Elektrokastengehäuse	
9.	3R00014	Ställbar låsspak	Locking lever	Sperrarm	
10.	3S02556	Skruv M6S	Screw	Schraube	12x120
11.	3S02558	Skruv M6S	Screw	Schraube	12x130
12.	3M09122	Låsmutter	Locking nut	Sicherungsmutter	M12
13.	3B04178	Bricka TRB	Washer	Scheibe	13x24x4

Växellåda – Gear box – Getriebegehäuse

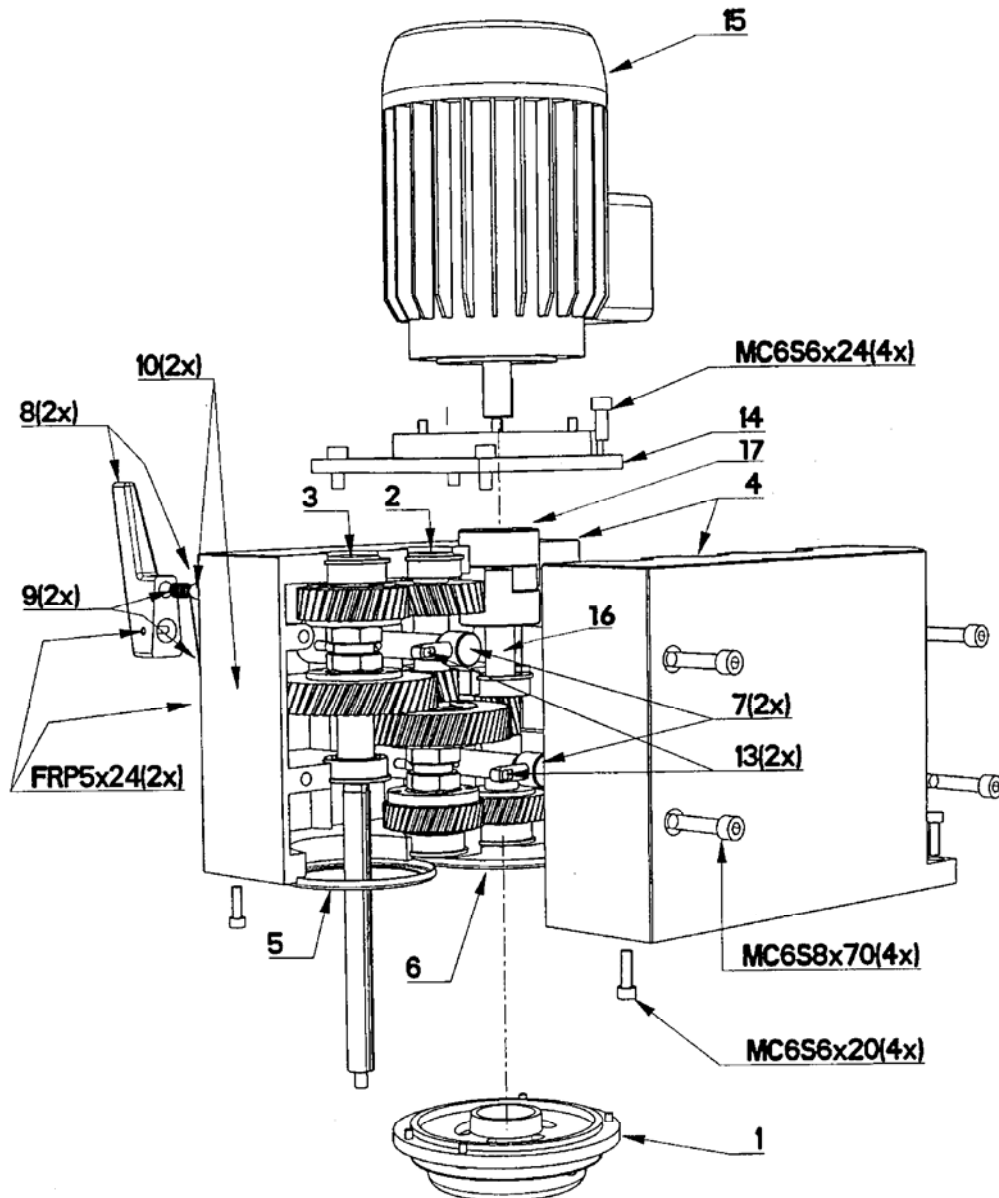

Pos	Art. No.	Benämning	Description	Benennung	Not
1.	4L02502-2	Täckplåt	Cover plate	Abdeckplatte	
2.	2X08404-2	2:a axel kompl.	2:nd shaft complete	2:e Welle kompl.	
3.	2X08404-3	3:e axel kompl.	3:rd shaft complete	3:e Welle kompl.	
4.	2X08772	Växellådshus kpl.	Gear box complete	Getriebekasten	
5.	4B00174	Styrring	Ring	Ring	
6.	4B00173	Styrring	Ring	Ring	
7.	2X08536	Skiftarm	Gear selector arm	Schaltarm	
8.	4RS0653-1	Växelspak	Gear lever	Schalthebel	
9.	4C02921	Fjäder	Gear	Feder	
10.	3T04028	Stålkula	Steel ball	Schaltgriff	
13.	4T04168	Skiftstift	Shift pin	Stift	
14.	2N08624	Motorfläns	Motor flange	Motorflansch	
15.	3E03005	Motor	Motor	Motor	230V
17.	2X08727	1:a axel kompl.	1:st shaft complete	1:e Welle kompl.	

Motoraxel – Engine shaft – Motorwelle

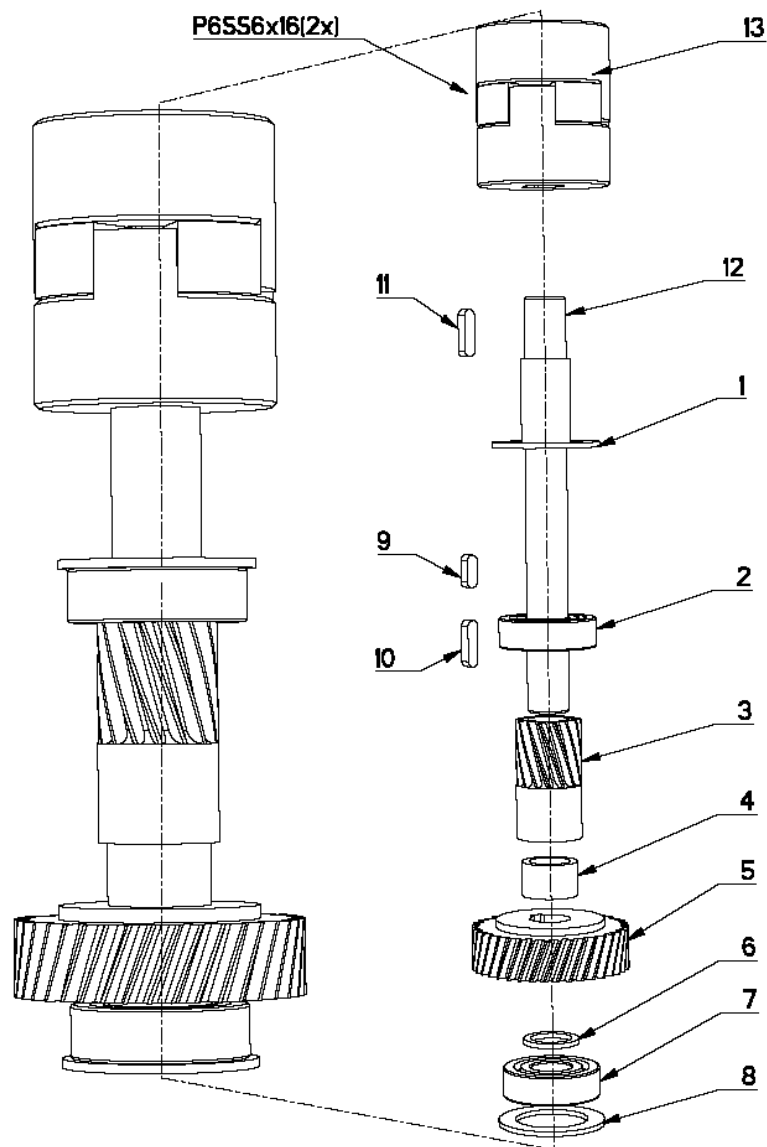

Pos	Art. No.	Benämning	Description	Benennung	Not
1.	4B00137	Lock	Washer	Scheibe	
2.	3L11003	Enrad spårkullager	Ball bearing	Kugellager	6203
3.	2H07969	Kugghjul	Gear	Zahnrad	15-1,5
4.	2D17014	Distanshylsa	Spacing sleeve	Distanzhülse	17x14
5.	2H07972	Kugghjul	Gear	Zahnrad	39-1,5
6.	2D17002	Distanshylsa	Spacing sleeve	Distanzhülse	17x2
7.	3L11003	Enrad spårkullager	Ball bearing	Kugellager	6203
8.	4B00137	Lock	Washer	Scheibe	
9.	3K00184	Kil	Key	Keil	5x5x14
10.	3K00187	Kil	Key	Keil	5x5x20
11.	3K00230	Kil	Key	Keil	6x6x20
12.	2A08727	Axel	Shaft	Welle	
13.	3XS0659	Axelkoppling	Shaft coupling	Wellenkupplung	

2:a axel – 2:nd shaft – 2:e Welle

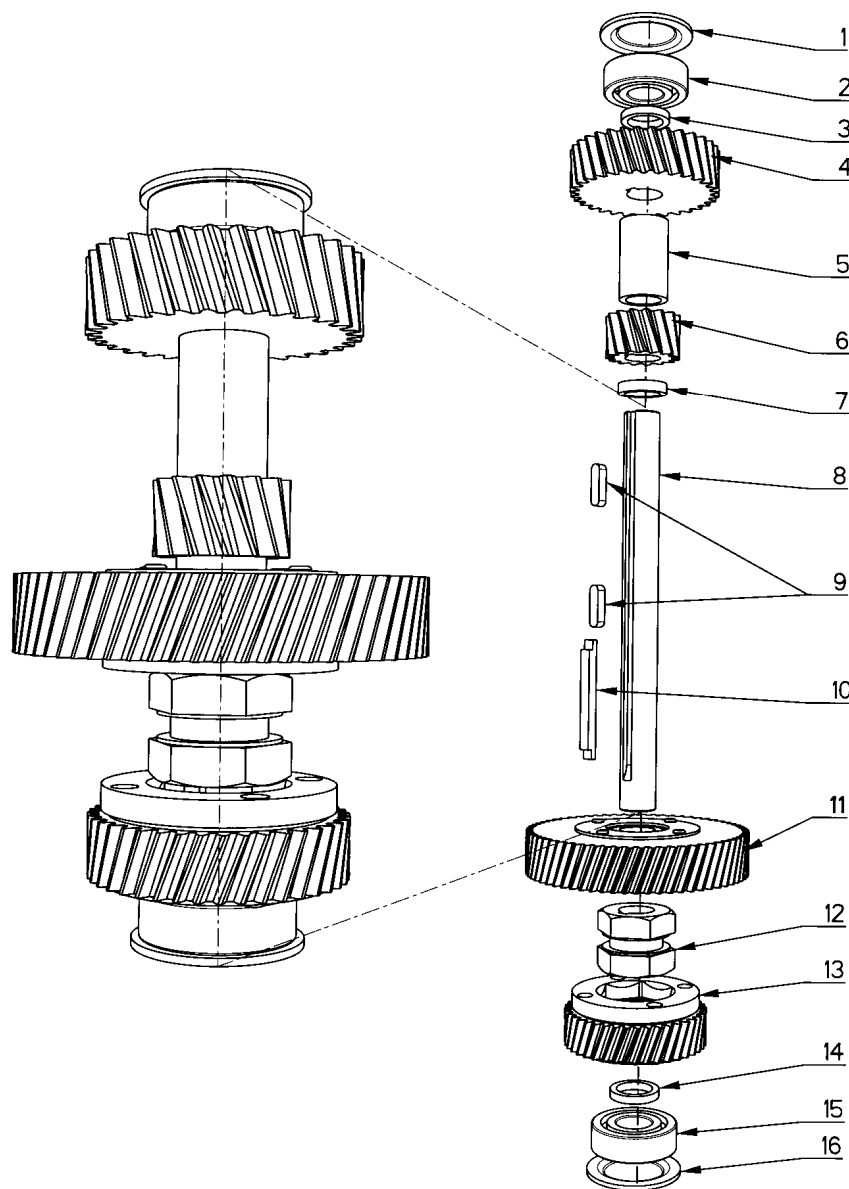

Pos	Art. No.	Benämning	Description	Benennung	Not
1.	4B00138	Lock	Washer	Scheibe	C-138
2.	3L11003	Enrad spårkullager	Ball bearing	Kugellager	6203
3.	2D00009	Distanshylsa	Spacing sleeve	Distanzhülse	17x3,5
4.	2H07971	Kuggjul	Gear	Zahnrad	32-2
5.	2D17038	Distanshylsa	Spacing sleeve	Distanzhülse	17x38
6.	2H07970	Kuggjul	Gear	Zahnrad	15-2
7.	2D00013	Distanshylsa	Spacing sleeve	Distanzhülse	17x5
8.	2A04871	2:a axel	2:nd shaft	2:e Welle	C-4871
9.	3K01187	Kil	Key	Keil	5x5x20
10.	2T06615	Övre kil	Key	Keil	C-6615
11.	2X08408R	Kuggjul kompl.	Gear complete	Zahnrad kompl.	64-1,5
12.	2T04254	Kopplingsklo	Clutch	Kupplung	C-4254
13.	2X08406R	Kuggjul kompl.	Gear complete	Zahnrad kompl.	40-1,5
14.	2D00009	Distanshylsa	Spacing sleeve	Distanzhülse	17x3,5
15.	3L11003	Enrad spårkullager	Ball bearing	Kugellager	6203
16.	4B00138	Lock	Cover	Deckel	C-138

3:e axel – 3:rd shaft – 3:e Welle

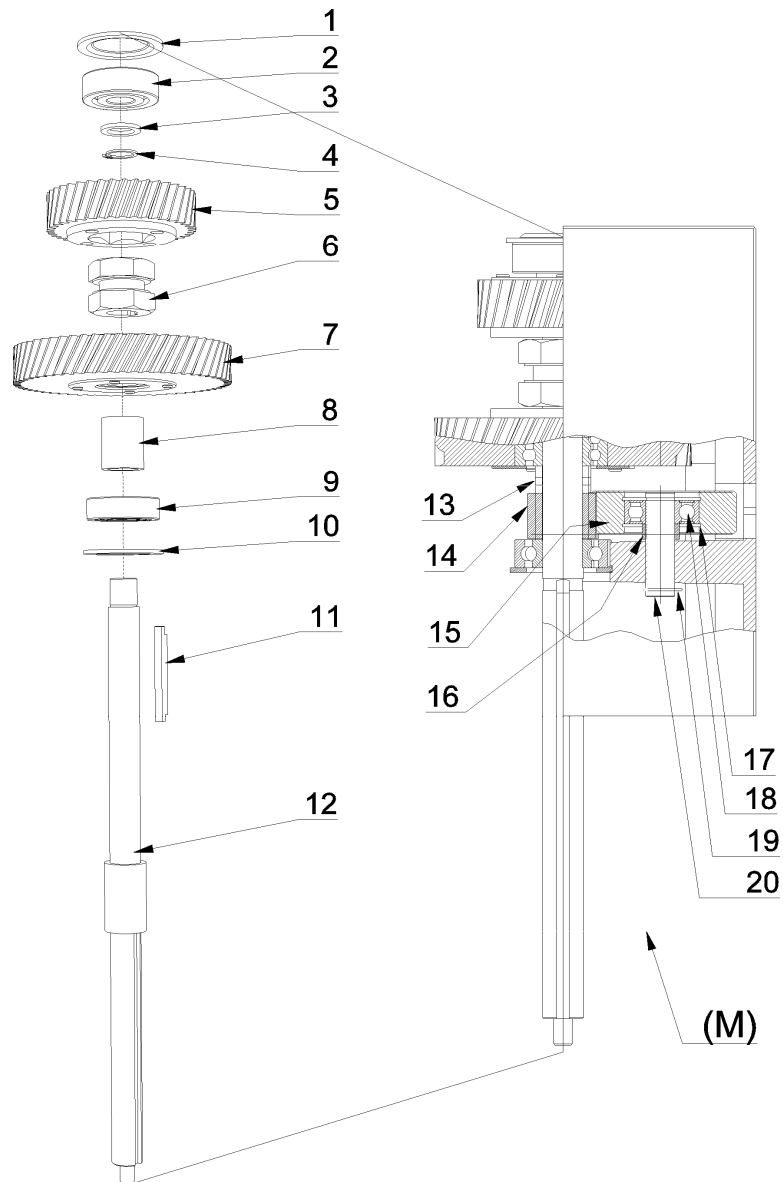

Pos	Art. No.	Benämning	Description	Benennung	Not
1.	4B08584	Lock	Cover	Deckel	C-138
2.	3L16002	Enrad spårkullager	Ball bearing	Kugellager	6302
3.	3D15002	Distanshylsa	Spacing sleeve	Distanzhülse	15x2
4.	3C01117	Spårring	Circlip	Führungsring	SgA 15
5.	2X08413R	Kuggghjul kompl.	Gear complete	Zahnrad kompl.	32-2
6.	2T04254	Kopplingsklo	Clutch	Kupplung	C 4254
7.	2X08411R	Kuggghjul kompl.	Gear complete	Zahnrad kompl.	49-2
8.	2D00006	Distanshylsa	Spacing sleeve	Distanzhülse	17x31,5
9.	3L11003	Enrad spårkullager	Ball bearing	Kugellager	6203
10.	4B00137	Lock	Cover	Deckel	C-137
11.	2T06615	Övre kil	Key	Keil	C-6615
12.	2A08410	3:e axel	3:rd shaft	3:e Welle	B-8410
13a.	2D00011	Distanshylsa 17x4,5	Spacer 17x4,5	Distanzhülse 17x4,5	2 st/pcs
13b.	2D00009	Distanshylsa 17x3,5	Spacer 17x3,5	Distanzhülse 17x3,5	1 st/pc
14.	2HSB7501-1	Kuggghjul	Gear whee	Zahnrad	18-1,5
15.	2X08558	Mellanhjul kompl.	Gear feed complete	Vorschubzahnrad kompl.	
16.	4D12006	Distanshylsa	Spacer	Distanzhülse	12x6,5
17.	3C02131	Spårring SGH 32	Circlip SGH 32	Sicherungsring SGH 32	2st/pcs
18.	3L13001	Kullager	Bearing	Kugellager	6201 2Z
19.	3C01114	Spårring	Circlip	Sicherungsring	SGA 12
20.	2A08441	Axel till mellanhjul	Feed gear shaft	Welle Vorschubzahnrad	

Pelare – Column – Säule

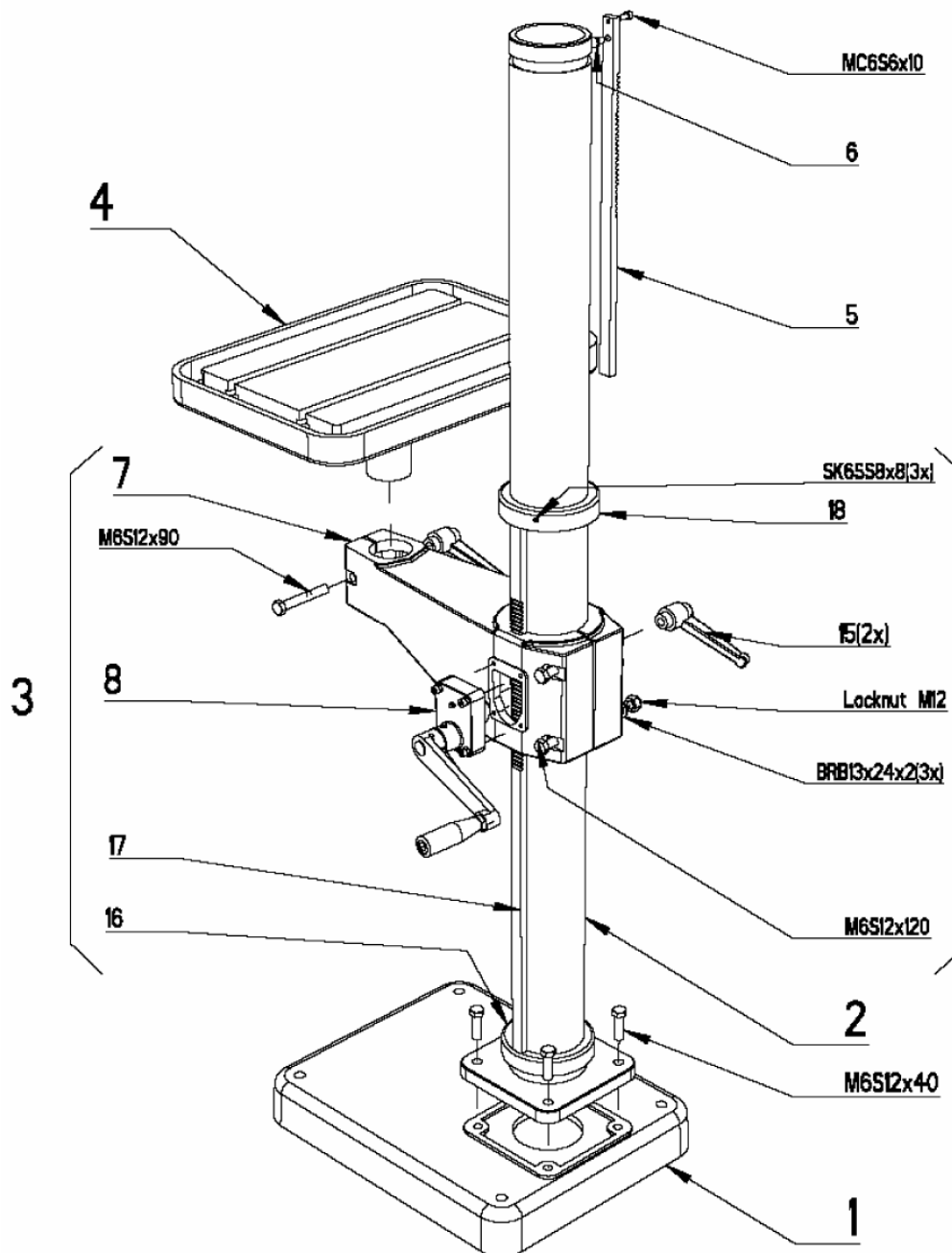

Pos	Art. No.	Benämning	Description	Benennung	Not
1.	1B03013	Fotplatta	Base plate	Fussplatte	
2.	4X08300	Pelare	Column	Säule	L=1500
3.	2X08723	Bordarm kompl.	Table arm complete	Tischarm kompl.	
4.	2WS1231	Fyrkantsbord	Table	Tisch	
5.	2X08445	Kuggstång	Rack	Zahnstange	
6.	2T07146	Tapp	Pin	Zapf	
7.	2Y08723	Bordarm	Table arm	Tischarm	
8.	2X08720-1R	Snäckväxel kompl.	Worm gear complete	Schneckengetriebe kompl.	
16.	2N00186R	Nedre ring	Lower ring	Unterer Ring	
17.	2I03598	Kuggstång	Rack	Zahnstange	
18.	2N03668R	Övre ring	Upper ring	Oberer Ring	

Pelare bänk – Column bench type drill – Säule Tischbohrmaschine

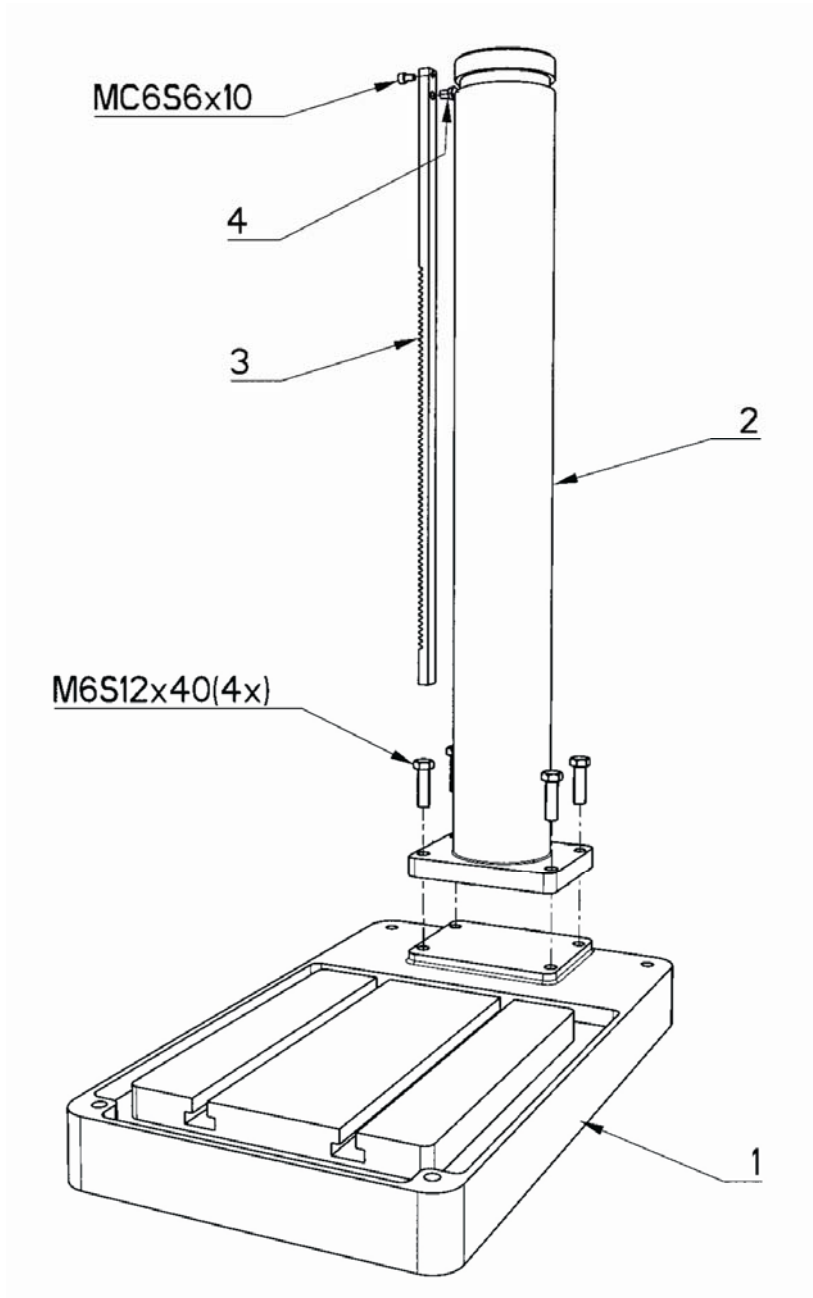

Pos	Art. No.	Benämning	Description	Benennung	Not
1.	1B03016	Bänkplatta	Base plate	Fussplatte	
2.	4ZS1232	Bänkelare	Column	Säule	
3.	2X08545	Kuggstång kompl.	Rack	Zahnstange	
4.	2T07146	Tapp	Pin	Zapfen	

2X08720 – Snäckväxelhus kompl. – Worm gear box compl. – Schneckengetriebegehäuse kompl.

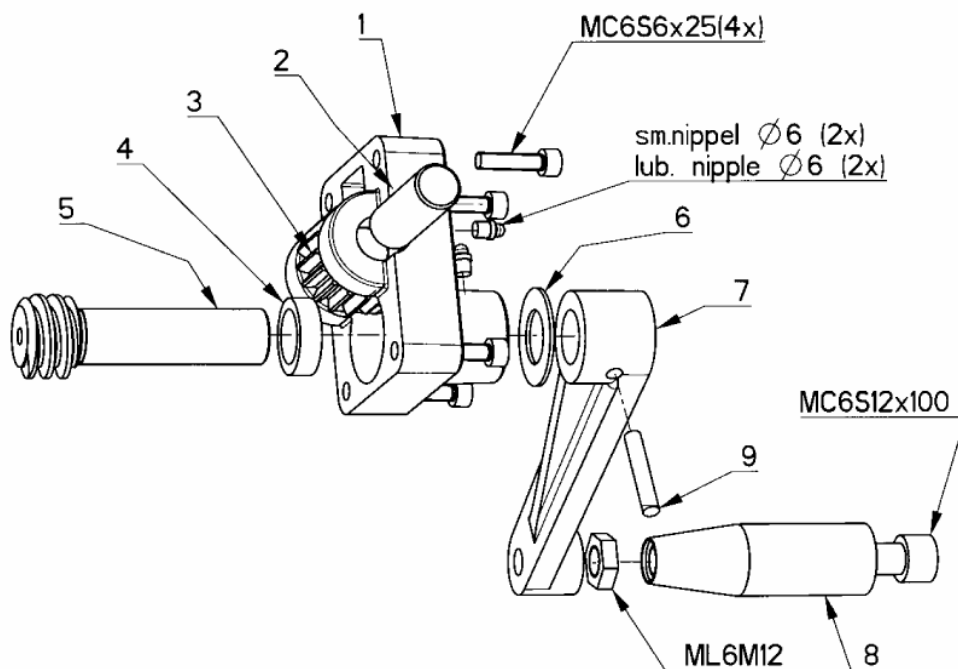
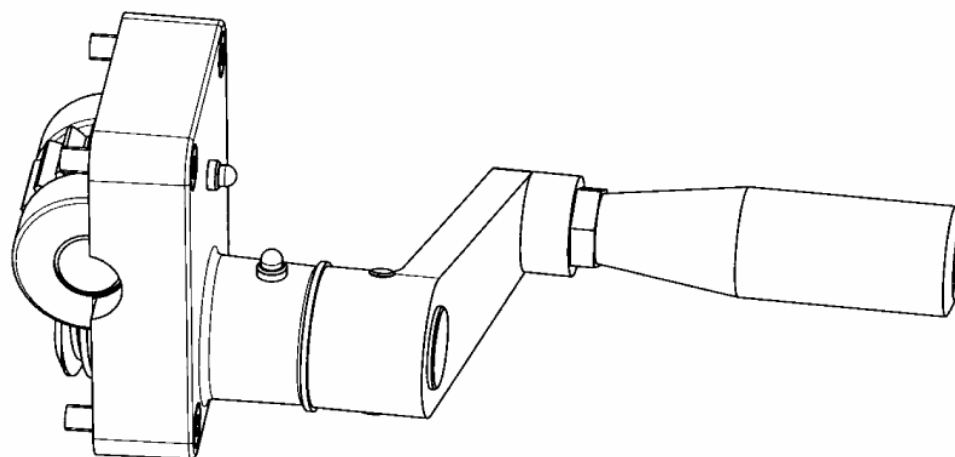

Pos	Art. No.	Benämning	Description	Benennung	Not
1.	2N08720	Snäckväxelhus	Worm gear box	Schneckengetriebegehäuse	
2.	2A08725	Axel	Shaft	Welle	
3.	2HS1201	Kuggjul	Gear	Zahnrad	
4.	2D20008	Distansring	Spacer	Distanzring	20x8
5.	2IS1203	Snäckskruv	Worm shaft	Schneckenwelle	
6.	3L00021	Glidbricka	Washer	Scheibe	
7.	2RS1182	Vev	Crank	Kurbel	
8.	3R01106	Handtag	Handle	Ballengriff	
9.	3S04444	Skruv	Screw	Schraube	SK6SS 8x8

Matningsaxel (manuell) – Feed shaft (manual) – Vorschubwelle (manuell)

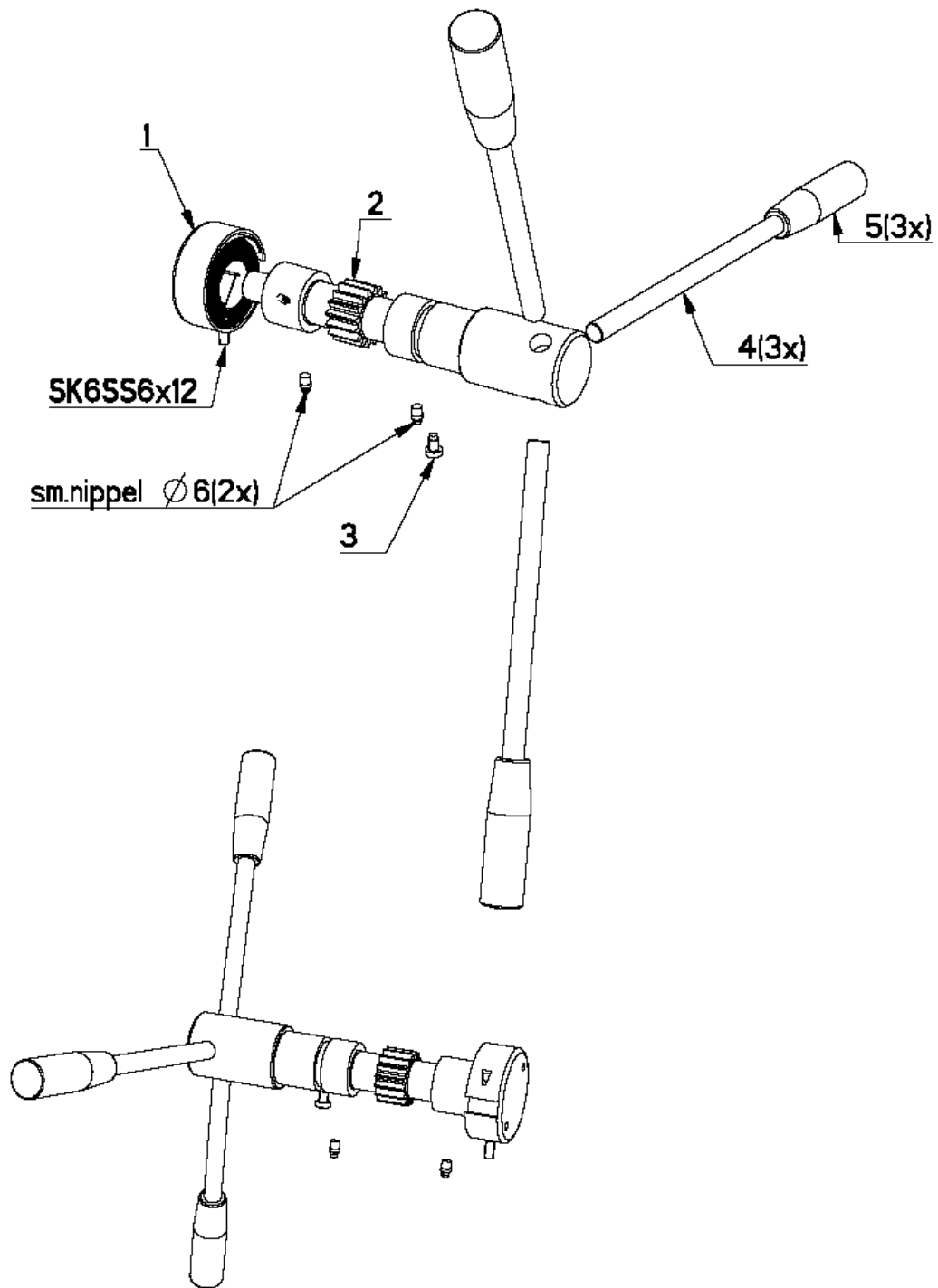

Pos	Art. No.	Benämning	Description	Benennung	Not
1.	4XS2150	Fjäderhus kompl.	Spring housing cpl.	Federgehäuse kompl.	
2.	2I08752	Matningsaxel	Feed shaft	Vorschubwelle	
3.	4S04211	Tappskruv	Pin screw	Zapfschraube	
4.	2E08758	Matningsspak	Feed lever	Vorschubhebel	3 st/pcs
5.	3R04004	Handtag	Handle	Ballengriff	3 st/pcs

Matningsaxel (M) – Feed shaft (M) – Vorschubwelle (M)

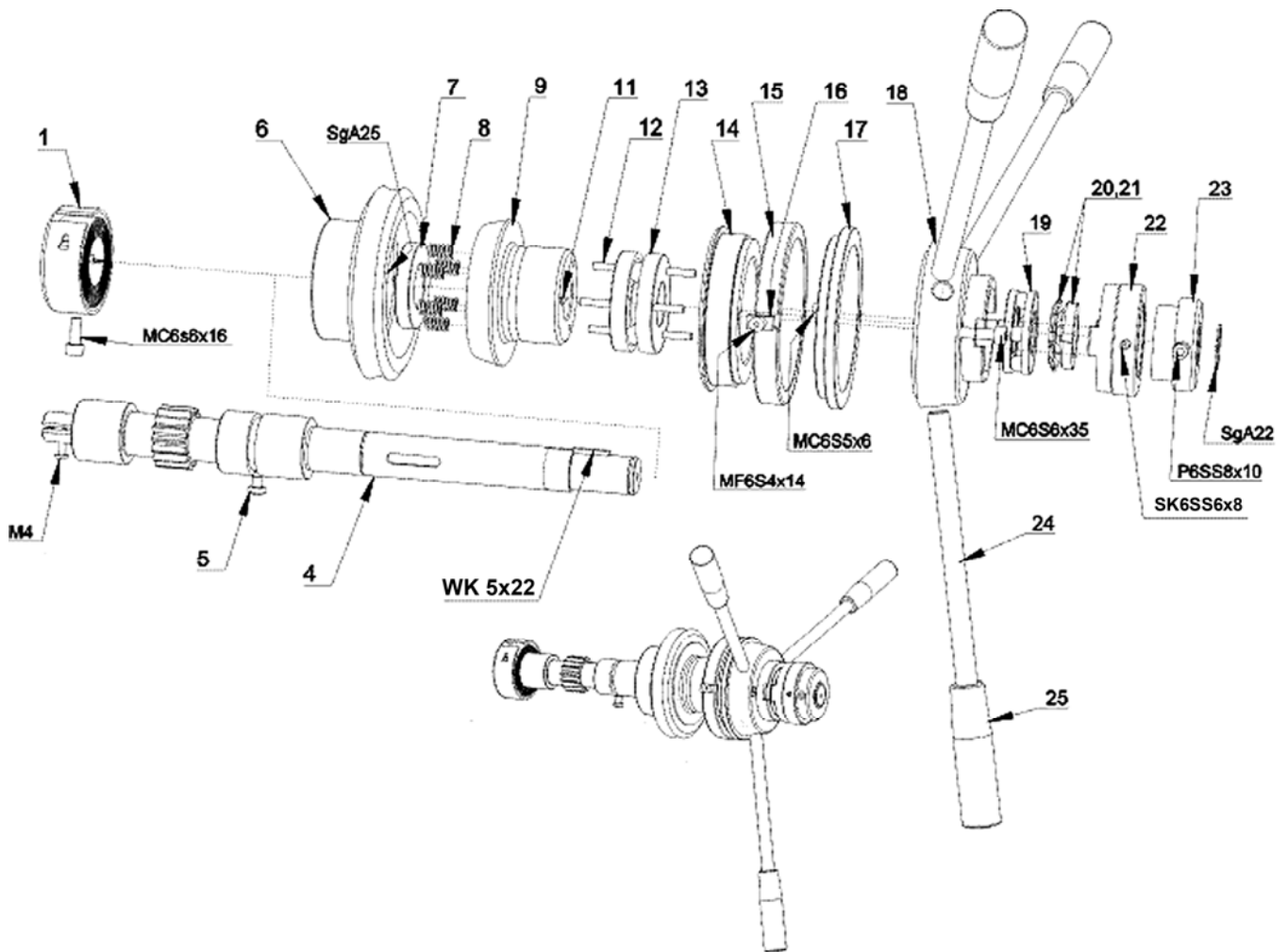

Pos	Art. No.	Benämning	Description	Benennung	Note
1	4XS2150	Returfjäder	Return spring	Rückholfeder	
4	2I08456	Matningsaxel	Feed shaft	Vorschubwelle	
5	4S04211	Styrskruv	Guide screw	Führungsschraube	
6	2ISB7523-2	Snäckhjul	Worm wheel	Schneckenrad	
7	2TSB142081	Tryckplatta	Pressure plate	Druckscheibe	
8	4CSB548090-2	Tryckfjäder	Clutch head spring	Druckfeder	6 st.
9	2NSB142080	Kopplingshuvud	Clutch head	Kupplungskopf	
11	3K01235	Kil	Key	Keil	
12	3P07257	Stift	Pin	Stift	6 st.
13	2TSB548091	Kopplingsskiva	Clutch half	Kupplungsscheibe	
14	2TSB548092	Låsring	Lock ring	Schliessring	
15	2TSB548093-1	Anslagsring	Stop ring	Stoppring	
16	2TSB548093-3	Anslagsklack	Trip dog lip	Anschlag	
17	2TSB548093-2	Ställring	Adjusting ring	Einstellung	
18	2TSB548094	Handspaksfäste	Handle holder	Griffhalter	
19	3L61005	Axialkullager	Bearing	Lager	
20	3B07005	Låsbricka	Locking washer	Blechsicherung	
21	3M06005	Mutter	Nut	Mutter	
22	2TSB548096-1	Klokoppling	Coupling clutch	Klauenkupplung	
23	2TSB548096-2	Nav för klokoppling	Coupling hub	Kupplungsnav	
24	2E02854	Spak	Feed lever	Vorschubhebel	3 st.
25	3R01005	Handtag	Handle	Ballengriff	3 st.

Spindelhylsa – Spindle sleeve – Spindelhülse

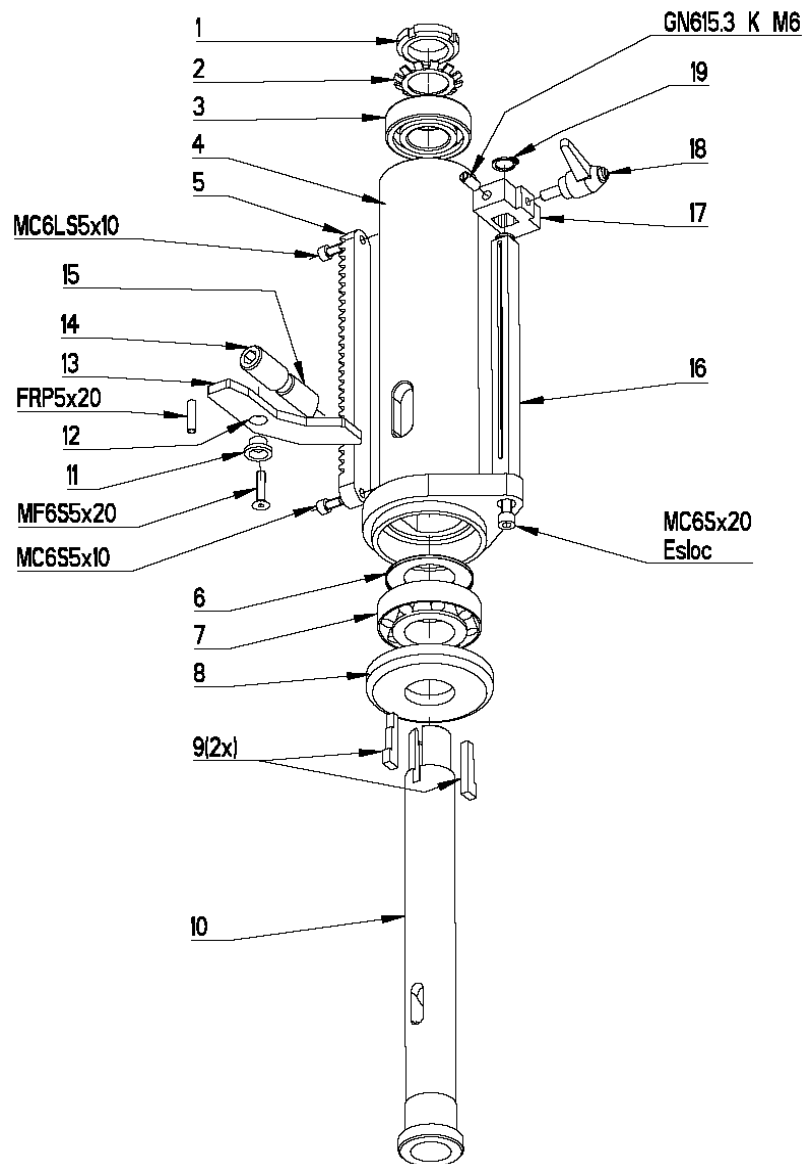

Pos	Art. No.	Benämning	Description	Benennung	Not
1.	3M06005	Mutter	Nut	Mutter	MK 5
2.	4B00155	Låsbricka	Locking washer	Sicherungsscheibe	
3.	3L15005	Enrad.spårkullager	Ball bearing	Kugellager	6205
4.	2G08710	Spindelhylsa	Spindle sleeve	Spindelhülse	
5.	2I08753	Kuggstång	Rack	Zahnstange	
6.	4B03769	Bricka	Washer	Scheibe	
7.	3L51006	Kon.rullager	Taper roller bearing	Rollenlager	30206
8.	2TS1106	Rullagerlock	Roller bearing cover	Rollenlagerdeckel	
9.	2T08386	Kil	Key	Keil	
10.	2A08418-1R	Borrspindel	Spindle	Bohrspindel	
11.	2T08593	Distanshylsa	Spacing sleeve	Distanzhülse	
12.	3B06003	Bricka	Washer	Scheibe	
13.	2T08547	Anslag	Stop	Anschlag	
14.	3S08622	Skruv	Screw	Schraube	P6SS 16x25
15.	2T08714	Klämback	Collet jaw	Klemmbacke	
16.	2A08755	Djupmåttstång	Depth gauge rod	Tiefenmassstange	
17.	2T08757	Stopp för matning	Stop	Anschlag	
18.	3R00002	Handtag	Locking lever	Klemmhebel	M6x16
19.	3C01114	Spårring	Circlip	Führungsring	SgA12

2X08705 – Ellåda – Electric Box – Elektrokasten

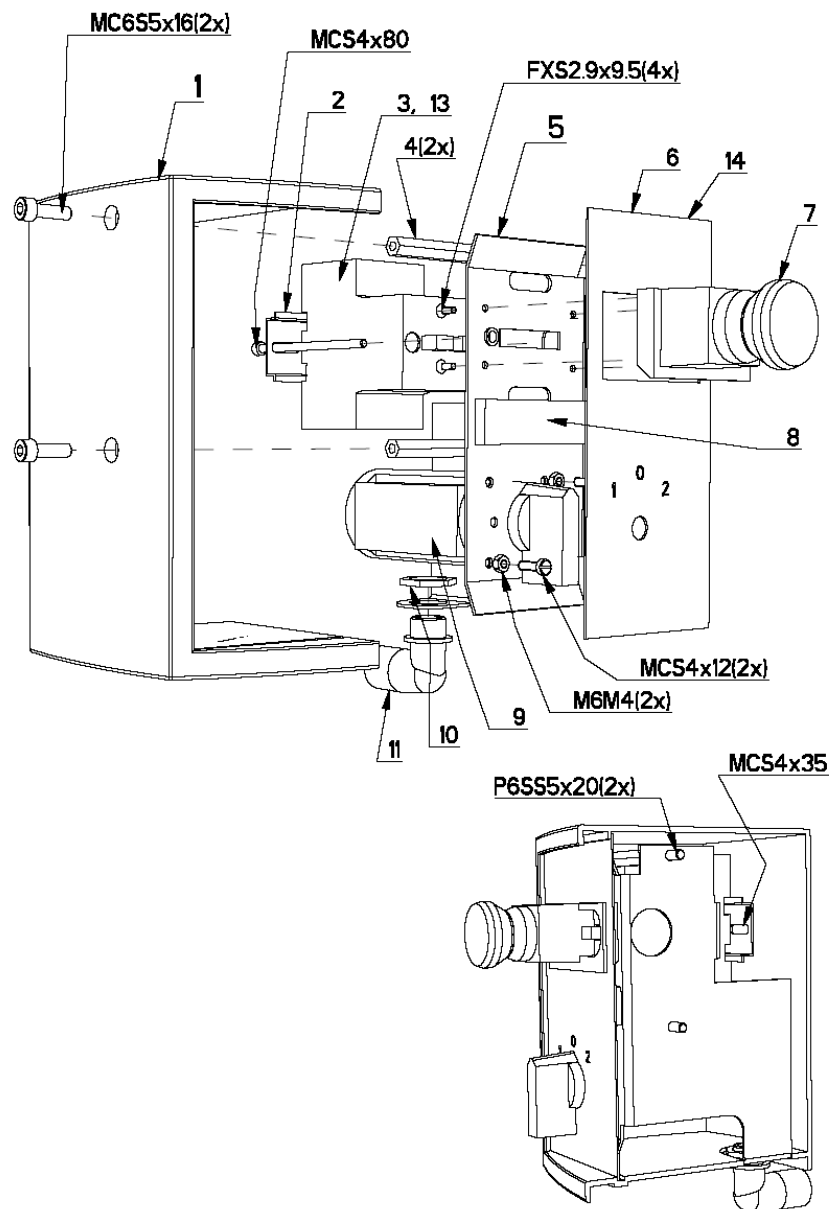

Pos	Art. Nr.	Benämning	Description	Benennung	Not
1.	2U08705	Elboxkåpa	Electric box cover	Elektrokastengehäuse	
2.	2L08712	Ankarsken	Rail anchor	Schienenklemme	
3.	3E10606	Motorskydd	Motor protector	Motorschutz	230V 50Hz
4.	2E08713	Elboxdistanspinne	Electric box dist. tube	Elektrokasten Abstandstift	
5.	4L08706	Fästplåt	Anchor plate	Halteblech	
6.	4L08711-X	Elboxpanel	Electric box plate	Elektrokastenschild	
7.	3E16227	Nödstoppknapp	Emergency stop	Notstopp	
8.	3T18003	Svampgummilist	Rubber moulding	Gummifassung	15x8 L=50
9.	3E06023	Handpolomkopl.	Pole reverser	Polumschalter	
10.	3E19083	Kontramutter	Nut	Mutter	
11.	3E19225	Förskruvning	Nipple	Verschraubung	
13.	3E10613	Undersp.utlösare	Low volt release	Unterspannungsauslöser	230V 50Hz
14.		Används ej	Not in use	Wird nicht verwendet	
15.	3E12006	Drift-Kondensator (inte i bild)	Run-Condensator (not in picture)	Trieb-Kondensator (nicht im Bild)	
16.	3E12007	Start-Kondensator (inte i bild)	Start-Condensator (not in picture)	Start-Kondensator (nicht im Bild)	

Måttskisser – Dimension sketches – Masskizzen

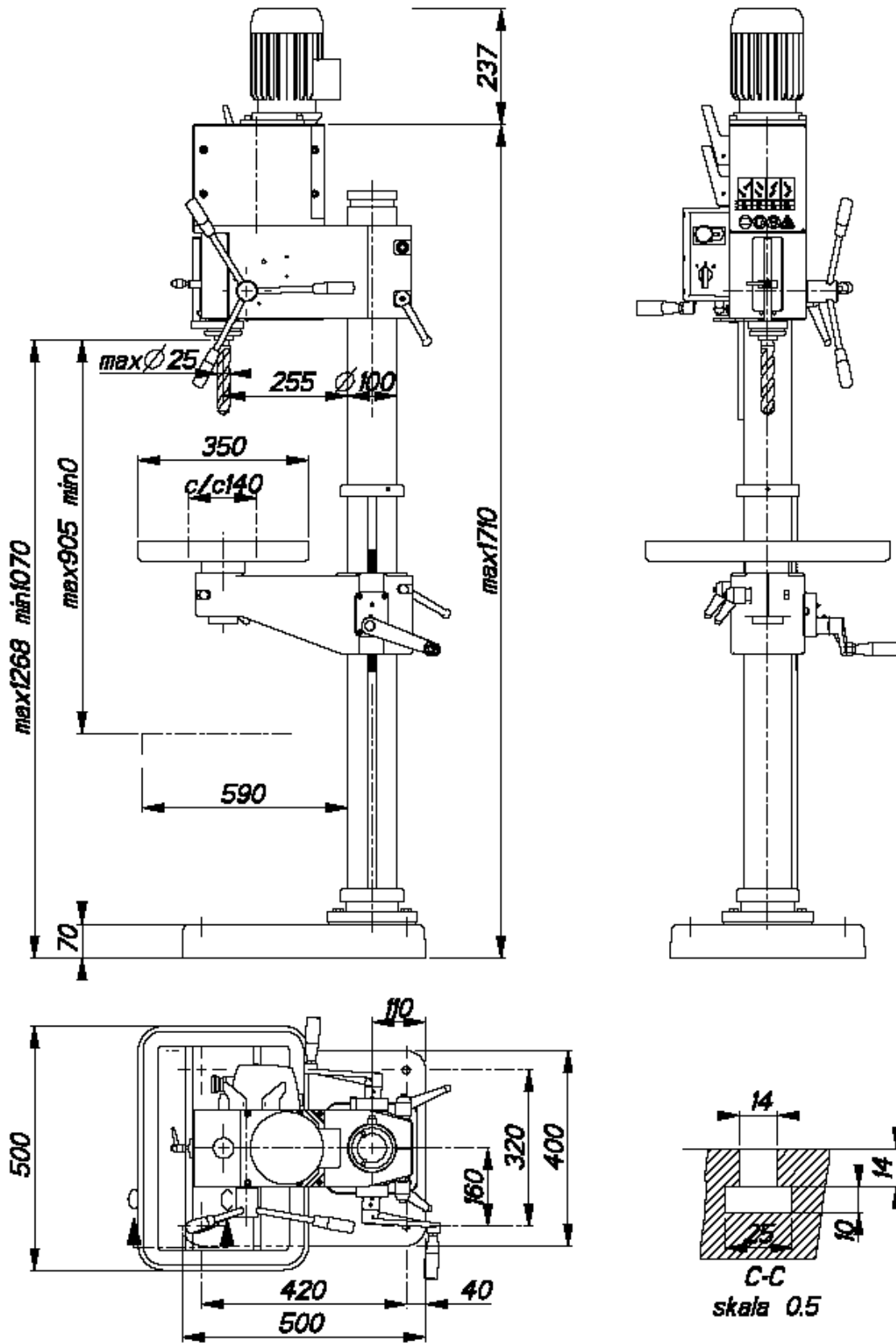

25 mm manuell matning – 25 mm manual feed – 25 mm manueller Vorschub

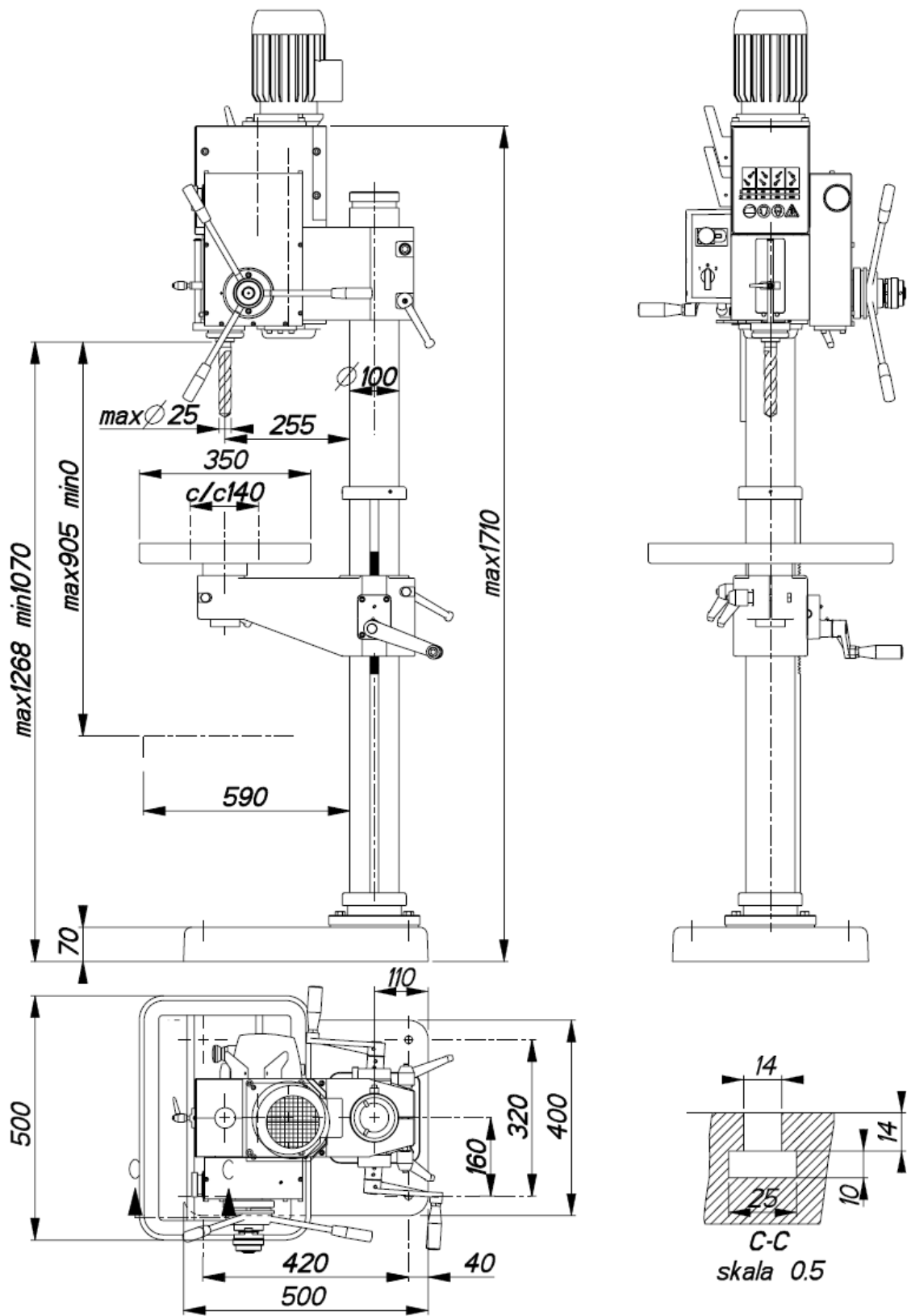

25 mm automatisk matning – 25 mm power feed – 25 mm automatischer Vorschub

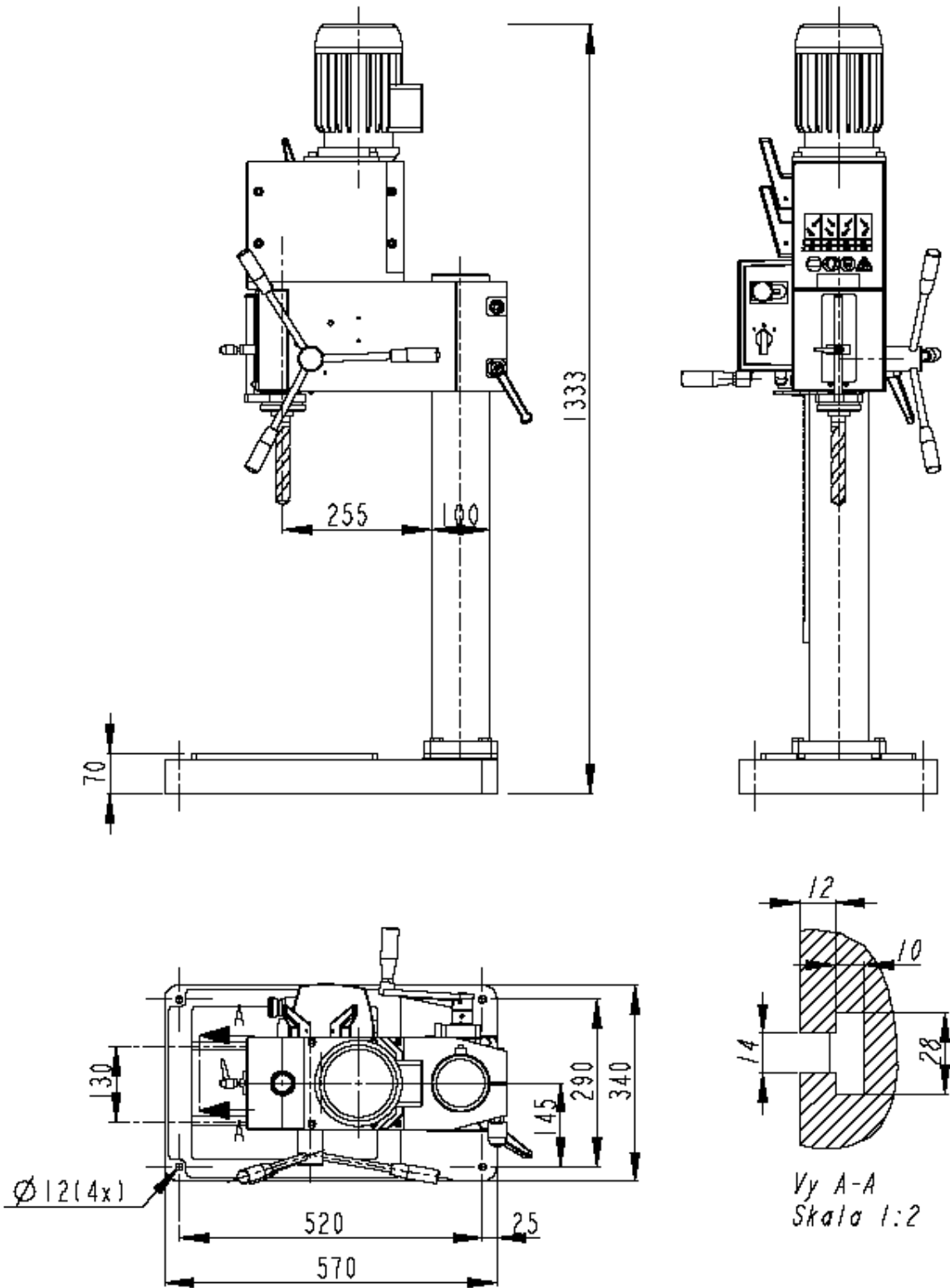

Bänk – Bench model – Tischmodell

Elschema – Electric diagram – Elektrodiagramm

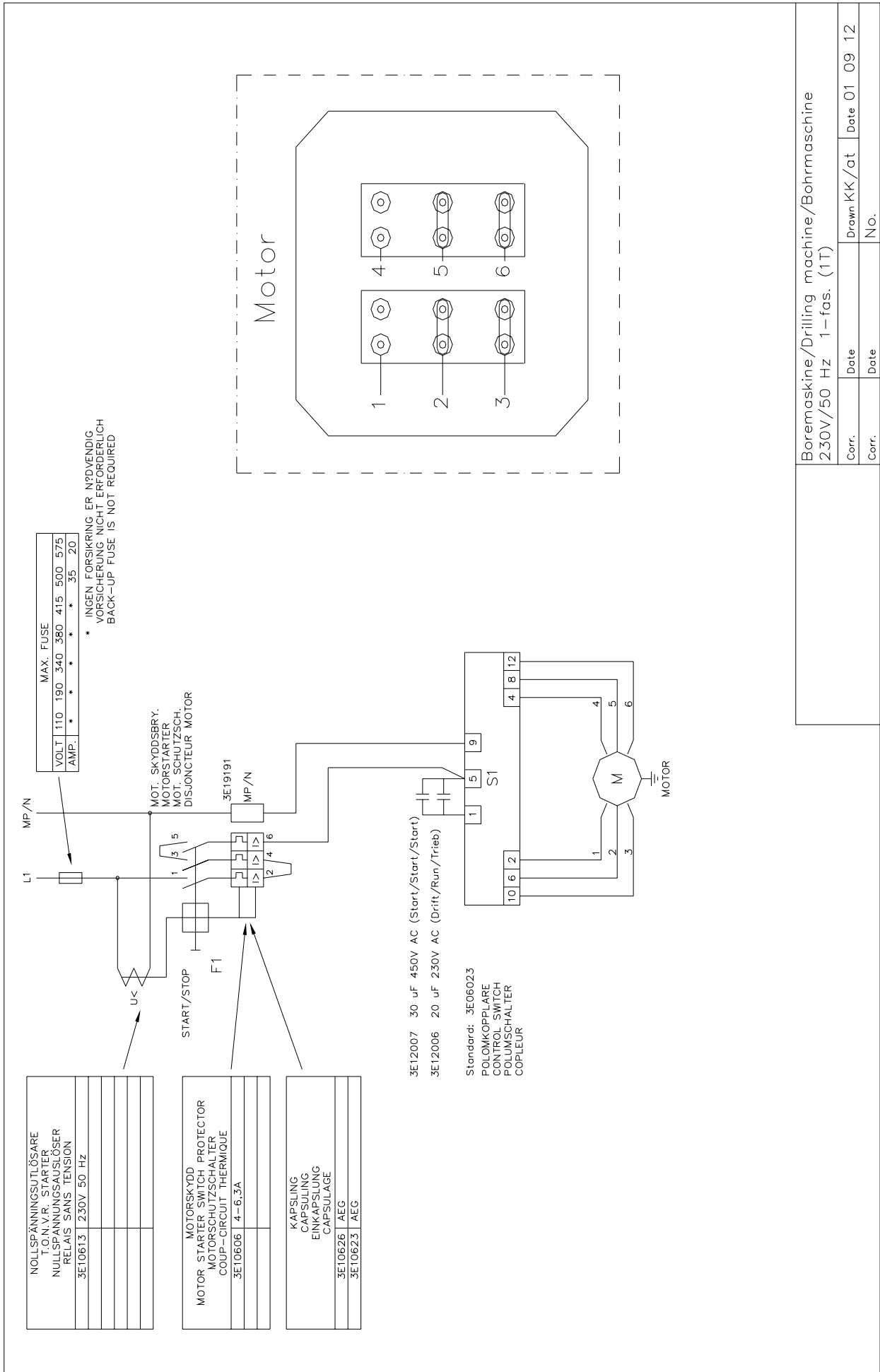

Boremaschine/Drilling machine/Bohrmaschine
230V/50 Hz 1-fas. (1T)

Corr.	Date	Drawn KK/at	Date 01 09 12
Corr.	Date	No.	

Oljerekommendationer (M) - Oil recommendations (M) – Öl (M)

Oil Company	Oil type
<i>OK Petroleum</i>	Delta Oil 68
<i>BP</i>	BP Maccurant 68, BP Bartran 68
<i>Castrol</i>	Castrol Hyspin AWS 68
<i>Texaco</i>	Texaco HD 68
<i>Statoil</i>	Nuto H68
<i>Mobil</i>	Mobil DTE 26, Mobil Vactra Oil No 2
<i>Shell</i>	Shell Tellus Oil 68, Shell X-100 10W/30

Maskiner med matningsväxellåda (M): för växellådor med kugghjul och kullager.

Viskositet: 5 °E vid 50 °C.

OBS! Maskinens garanti är baserad på dessa oljerekommendationer – vid normala temperaturer.

Machines with power feed (M): for gear boxes with gear wheels and ball bearings.

Viscosity: 5 °E at 50 °C.

NOTE! The guarantee of the machine is based on these oil recommendations – at normal temperatures.

Maschinen mit automatischem Vorschub (M): für Zahnradgetriebe mit Kugellagern.

Ölviskosität 5 °E bei 50 °C.

HINWEIS! Die Maschinengarantie ist an diese Empfehlungen gekoppelt – bei normaler Temperatur.