



Operating Instructions and Parts Manual

18-inch Metal/Wood Cutting Band Saw

Model VBS-18MW



JET

427 New Sanford Road
LaVergne, TN 37086-4184, USA
Ph.: 800-274-6848
www.jettools.com

Part No. M-414418
Revision C 04/2015
(ECR TW0126)
Copyright © 2015 JET

1.0 Warranty and Service

JET® warrants every product it sells against manufacturers' defects. If one of our tools needs service or repair, please contact Technical Service by calling 1-800-274-6846, 8AM to 5PM CST, Monday through Friday.

Warranty Period

The general warranty lasts for the time period specified in the literature included with your product or on the official JET branded website.

- JET products carry a limited warranty which varies in duration based upon the product. (See chart below)
- Accessories carry a limited warranty of one year from the date of receipt.
- Consumable items are defined as expendable parts or accessories expected to become inoperable within a reasonable amount of use and are covered by a 90 day limited warranty against manufacturer's defects.

Who is Covered

This warranty covers only the initial purchaser of the product from the date of delivery.

What is Covered

This warranty covers any defects in workmanship or materials subject to the limitations stated below. This warranty does not cover failures due directly or indirectly to misuse, abuse, negligence or accidents, normal wear-and-tear, improper repair, alterations or lack of maintenance. JET woodworking machinery is designed to be used with Wood. Use of these machines in the processing of metal, plastics, or other materials outside recommended guidelines may void the warranty. The exceptions are acrylics and other natural items that are made specifically for wood turning.

Warranty Limitations

Woodworking products with a Five Year Warranty that are used for commercial or industrial purposes default to a Two Year Warranty. Please contact Technical Service at 1-800-274-6846 for further clarification.

How to Get Technical Support

Please contact Technical Service by calling 1-800-274-6846. **Please note that you will be asked to provide proof of initial purchase when calling.** If a product requires further inspection, the Technical Service representative will explain and assist with any additional action needed. JET has Authorized Service Centers located throughout the United States. For the name of an Authorized Service Center in your area call 1-800-274-6846 or use the Service Center Locator on the JET website.

More Information

JET is constantly adding new products. For complete, up-to-date product information, check with your local distributor or visit the JET website.

How State Law Applies

This warranty gives you specific legal rights, subject to applicable state law.

Limitations on This Warranty

JET LIMITS ALL IMPLIED WARRANTIES TO THE PERIOD OF THE LIMITED WARRANTY FOR EACH PRODUCT. EXCEPT AS STATED HEREIN, ANY IMPLIED WARRANTIES OF MERCHANTABILITY AND FITNESS FOR A PARTICULAR PURPOSE ARE EXCLUDED. SOME STATES DO NOT ALLOW LIMITATIONS ON HOW LONG AN IMPLIED WARRANTY LASTS, SO THE ABOVE LIMITATION MAY NOT APPLY TO YOU.

JET SHALL IN NO EVENT BE LIABLE FOR DEATH, INJURIES TO PERSONS OR PROPERTY, OR FOR INCIDENTAL, CONTINGENT, SPECIAL, OR CONSEQUENTIAL DAMAGES ARISING FROM THE USE OF OUR PRODUCTS. SOME STATES DO NOT ALLOW THE EXCLUSION OR LIMITATION OF INCIDENTAL OR CONSEQUENTIAL DAMAGES, SO THE ABOVE LIMITATION OR EXCLUSION MAY NOT APPLY TO YOU.

JET sells through distributors only. The specifications listed in JET printed materials and on official JET website are given as general information and are not binding. JET reserves the right to effect at any time, without prior notice, those alterations to parts, fittings, and accessory equipment which they may deem necessary for any reason whatsoever. JET® branded products are not sold in Canada by JPW Industries, Inc.

Product Listing with Warranty Period

90 Days – Parts; Consumable items; Light-Duty Air Tools
1 Year – Motors; Machine Accessories; Heavy-Duty Air Tools; Pro-Duty Air Tools
2 Year – Metalworking Machinery; Electric Hoists, Electric Hoist Accessories
5 Year – Woodworking Machinery
Limited Lifetime – JET Parallel clamps; VOLT Series Electric Hoists; Manual Hoists; Manual Hoist Accessories; Shop Tools; Warehouse & Dock products; Hand Tools

NOTE: JET is a division of JPW Industries, Inc. References in this document to JET also apply to JPW Industries, Inc., or any of its successors in interest to the JET brand.

2.0 Table of Contents

1.0 Warranty and Service	2
2.0 Table of Contents	3
3.0 Safety warnings	4
4.0 Introduction.....	6
5.0 Specifications	6
6.0 Grounding Instructions.....	6
6.1 115 Volt Operation	7
6.2 230 Volt Operation	7
6.3 Extension cords.....	7
7.0 Unpacking	8
7.1 Contents of Shipping Container	8
8.0 Assembly.....	9
8.1 Handwheel.....	9
8.2 Mounting the Table.....	9
8.3 Rail Assembly	9
8.4 Chip Tray	10
8.5 Dust Collection.....	10
8.6 Fence Assembly and Adjustment.....	10
8.7 Resaw Guide	12
8.8 Miter Gauge	12
9.0 Adjustments.....	12
9.1 Table Tilt.....	12
9.2 Adjusting 90 Degree Table Stop	13
9.3 Speed Adjustments	13
9.4 Installing/Changing Blades	14
9.5 Blade Tension	15
9.6 Blade Tracking	15
9.7 Overview – Bearing Adjustments.....	16
9.8 Upper Bearing Adjustments.....	16
9.9 Lower Bearing Adjustments.....	17
9.10 Blade Lead.....	18
9.11 Replacing the V-Belt.....	19
9.12 Belt Tension	19
9.13 Pulley Alignment	20
10.0 Electrical Connections.....	20
11.0 Operation.....	21
11.1 General Procedure.....	21
11.2 Ripping.....	21
11.3 Crosscutting	21
11.4 Resawing	22
11.5 Saw Blade Selection.....	22
11.6 Blade Breakage.....	23
12.0 Maintenance	23
12.1 Replacing Tires	24
13.0 Periodic Maintenance	24
14.0 Blade Selection Guide.....	25
15.0 Blade Speed per Materials Chart	26
16.0 Troubleshooting VBS-18MW Band Saw	27
17.0 Replacement Parts	29
17.1.1 Upper Wheel Assembly	30
17.1.2 Parts List: Upper Wheel Assembly.....	31
17.2.1 Lower Wheel and Motor Assembly.....	32
17.2.2 Parts List: Lower Wheel and Motor Assembly	33
17.3.1 Blade Guide Assembly	35
17.3.2 Parts List: Blade Guide Assembly	36
17.4.1 Table and Fence Assembly	38
17.4.2 Parts List: Table and Fence Assembly.....	39
18.0 Electrical Connections.....	40



3.0 Safety warnings

1. Read and understand the entire owner's manual before attempting assembly or operation.
2. Read and understand the warnings posted on the machine and in this manual. Failure to comply with all of these warnings may cause serious injury.
3. Replace the warning labels if they become obscured or removed.
4. This band saw is designed and intended for use by properly trained and experienced personnel only. If you are not familiar with the proper and safe operation of a band saw, do not use until proper training and knowledge have been obtained.
5. Do not use this band saw for other than its intended use. If used for other purposes, JET, disclaims any real or implied warranty and holds itself harmless from any injury that may result from that use.
6. Always wear approved safety glasses/face shields while using this band saw. Everyday eyeglasses only have impact resistant lenses; they are not safety glasses.
7. Before operating this band saw, remove tie, rings, watches and other jewelry, and roll sleeves up past the elbows. Remove all loose clothing and confine long hair. Non-slip footwear or anti-skid floor strips are recommended. Do not wear gloves.
8. Wear ear protectors (plugs or muffs) during extended periods of operation.
9. Some dust created by power sanding, sawing, grinding, drilling and other construction activities contain chemicals known to cause cancer, birth defects or other reproductive harm. Some examples of these chemicals are:
 - Lead from lead based paint.
 - Crystalline silica from bricks, cement and other masonry products.
 - Arsenic and chromium from chemically treated lumber.

Your risk of exposure varies, depending on how often you do this type of work. To reduce your exposure to these chemicals, work in a well-ventilated area and work with

approved safety equipment, such as face or dust masks that are specifically designed to filter out microscopic particles.

10. Do not operate this machine while tired or under the influence of drugs, alcohol or any medication.
11. Make certain the switch is in the OFF position before connecting the machine to the power supply.
12. Make certain the machine is properly grounded.
13. Make all machine adjustments or maintenance with the machine unplugged from the power source.
14. Remove adjusting keys and wrenches. Form a habit of checking to see that keys and adjusting wrenches are removed from the machine before turning it on.
15. Keep safety guards in place at all times when the machine is in use. If removed for maintenance purposes, use extreme caution and replace the guards immediately.
16. Check damaged parts. Before further use of the machine, a guard or other part that is damaged should be carefully checked to determine that it will operate properly and perform its intended function. Check for alignment of moving parts, binding of moving parts, breakage of parts, mounting and any other conditions that may affect its operation. A guard or other part that is damaged should be properly repaired or replaced.
17. Provide for adequate space surrounding work area and non-glare, overhead lighting.
18. Keep the floor around the machine clean and free of scrap material, oil and grease.
19. Keep visitors a safe distance from the work area. **Keep children away.**
20. Make your workshop child proof with padlocks, master switches or by removing starter keys.
21. Give your work undivided attention. Looking around, carrying on a conversation and "horse-play" are careless acts that can result in serious injury.
22. Maintain a balanced stance at all times so that you do not fall or lean against the blade or other moving parts. Do not overreach or use excessive force to perform any machine operation.

23. Use the right tool at the correct speed and feed rate. Do not force a tool or attachment to do a job for which it was not designed. The right tool will do the job better and safer.
24. Use recommended accessories; improper accessories may be hazardous.
25. Maintain tools with care. Keep blades sharp and clean for the best and safest performance. Follow instructions for lubricating and changing accessories.
26. Turn off the machine before cleaning. Use a brush or compressed air to remove chips, shavings or debris — do not use your hands.
27. Do not stand on the machine. Serious injury could occur if the machine tips over.
28. Never leave the machine running unattended. Turn the power off and do not leave the machine until it comes to a complete stop.
29. Remove loose items and unnecessary work pieces from the area before starting the machine.

Familiarize yourself with the following safety notices used in this manual:

⚠CAUTION This means that if precautions are not heeded, it may result in minor injury and/or possible machine damage.

⚠WARNING This means that if precautions are not heeded, it may result in serious injury or possibly even death.

- - SAVE THESE INSTRUCTIONS - -

4.0 Introduction

This manual is provided by JET, covering the safe operation and maintenance procedures for a JET Model VBS-18MW Band Saw. This manual contains instructions on installation, safety precautions, general operating procedures, maintenance instructions and parts breakdown. This machine has been designed and constructed to provide consistent, long-term operation if used in accordance with instructions set forth in this manual. If there are any questions or comments, please contact either your local supplier or JET. JET can also be reached at our web site: www.jettools.com.

5.0 Specifications

Model Number.....	VBS-18MW
Stock Number	414418
Cutting Capacity (height) (in.)	12
Cutting Capacity (width) (in.)	18-3/8
Maximum Rip Left of Blade w/Fence (in.)	16-1/2
Blade Length (in.)	137
Blade Speeds (SFPM):	
High Gear	1000, 1800, 3200
Low Gear.....	80, 150, 265
Minimum Blade Width (in.)	1/8
Maximum Blade Width – Wood (in.)	1-1/2
Maximum Blade Width – Metal (in.)	1
Table Size (in.)	19 x 19
Front of Table to Center of Blade (in.)	10
Table Tilt (deg.)	45°R to 10°L
Table Height from Floor (in.)	37-1/2
Wheel Diameter (in.)	18-5/8
Dust Port Diameter (in.)	4
Base Footprint (in.)	18 x 29
Overall Dimensions (HxWxD) (in.)	74 x 42 x 38
Motor	1-1/2 HP, 1Ph, 115/230V (pre-wired 115V)
Net Weight – approximate (lbs.)	456
Shipping Weight – approximate (lbs.)	582

The above specifications were current at the time this manual was published, but because of our policy of continuous improvement, JET reserves the right to change specifications at any time and without prior notice, without incurring obligations.

6.0 Grounding Instructions

⚠WARNING Electrical connections must be made by a qualified electrician in compliance with all relevant codes. The machine must be properly grounded to help prevent electrical shock and possible fatal injury.

In the event of a malfunction or breakdown, grounding provides a path of least resistance for electric current to reduce the risk of electric shock. This tool is equipped with an electric cord having an equipment-grounding conductor and a grounding plug. The plug must be plugged into a matching outlet that is properly installed and grounded in accordance with all local codes and ordinances.

Do not modify the plug provided. If it will not fit the outlet, have the proper outlet installed by a qualified electrician.

Improper connection of the equipment-grounding conductor can result in a risk of electric shock. The conductor, with insulation having an outer surface that is green with or without yellow stripes, is the equipment-grounding conductor. If repair or replacement of the electric cord or plug is necessary, do not connect the equipment-grounding conductor to a live terminal.

Check with a qualified electrician or service personnel if the grounding instructions are not completely understood, or if in doubt as to whether the tool is properly grounded. Use only three wire extension cords that have three-prong grounding plugs and three-pole receptacles that accept the tool's plug.

6.1 115 Volt Operation

The VBS-18MW band saw is wired from the factory for 115 volt operation. The power cord has a *plug* that looks like A, Figure 1, and is used in an *outlet* that looks like B, Figure 1. A *temporary adapter* with a *grounding ear* secured with a *screw* (C, Figure 1) may be used to connect this plug to a two-pole receptacle if a properly grounded outlet is not available. The temporary adapter should only be used until a properly grounded outlet can be installed by a qualified electrician. **This adapter is not applicable in Canada.** The green colored *grounding ear*, lug, or tsab, extending from the adapter, must be connected to a permanent ground such as a properly grounded outlet box, as shown in C, Figure 1.

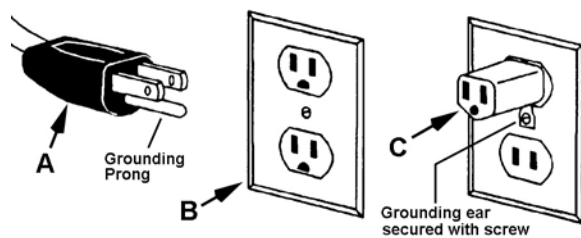

Figure 1

It is recommended that the **Band Saw** when operated at **115 volts**, be connected to a dedicated, *minimum* 30 amp circuit with a 30 amp circuit breaker or time delay fuse. **Local codes take precedence over recommendations.**

6.2 230 Volt Operation

If 230V, single phase operation is desired, the following instructions must be followed:

1. Disconnect machine from the power source.
2. This band saw is supplied with four motor leads that are connected for 115V operation. For 230V operation, re-connect the leads as shown in the diagram inside the motor junction box. The diagram is replicated on page 40 of this manual.
3. The 115V attachment plug supplied with the band saw must be replaced with a UL/CSA listed plug suitable for 230V operation, similar to that shown in Figure 2. Contact your local Authorized JET Service Center or qualified electrician for proper procedures to install the plug. The band saw must comply with all local and national codes after the 230V plug is installed.
4. The band saw with a 230V plug should only be connected to an outlet having the same configuration (Figure 2). No adapter is

available or should be used with the 230V plug.

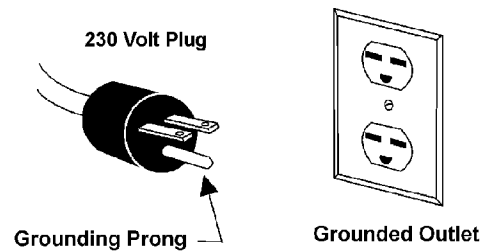

Figure 2

It is recommended that the **Band Saw** when operated at **230 volts**, be connected to a dedicated, *minimum* 15 amp circuit with a 15 amp circuit breaker or time delay fuse. **Local codes take precedence over recommendations.**

Important: In all cases (115 or 230 volts), make certain the receptacle in question is properly grounded. If you are not sure, have a registered electrician check the receptacle.

6.3 Extension cords

The use of an extension cord is not recommended for this band saw; try to position the machine within reach of the power supply. If an extension cord is necessary, make sure the cord rating is suitable for the amperage listed on the machine's motor plate. An undersized cord will cause a drop in line voltage resulting in loss of power and overheating.

Use the chart in Figure 3 as a general guide in choosing the correct size cord. If in doubt, use the next heavier gauge. The smaller the gauge number, the heavier the cord.

Recommended Gauges (AWG) of Extension Cords

Amps	Extension Cord Length *					
	25 feet	50 feet	75 feet	100 feet	150 feet	200 feet
< 5	16	16	16	14	12	12
5 to 8	16	16	14	12	10	NR
8 to 12	14	14	12	10	NR	NR
12 to 15	12	12	10	10	NR	NR
15 to 20	10	10	10	NR	NR	NR
21 to 30	10	NR	NR	NR	NR	NR

*based on limiting the line voltage drop to 5V at 150% of the rated amperes.

NR: Not Recommended.

Figure 3

Note: Figures in this manual may or may not exactly match the appearance of your machine.

7.0 Unpacking

7.1 Contents of Shipping Container

- 1 Band Saw
- 1 Table
- 1 Fence and Rail Assembly
- 1 Resaw Guide and Knob
- 1 Miter Gauge
- 1 Upper Chip Tray
- 1 Owner's Manual
- 1 Warranty Card
- 1 Accessory Package Contains:
 - Hardware Bag*
 - 2 Knobs
 - 1 Handle
 - 1 10/12mm Wrench
 - 2 Screws, 1/4-20x1/4" (Upper Chip Tray)
 - Fence Hardware Bag*
 - 4 Socket Head Cap Screws, 5/16x3/4"
 - 4 Flat Washers, 5/16"
 - 4 Lock Washers, 5/16"
 - Rail Hardware Bag*
 - 9 Hex Cap Screws, 1/4-20 x 5/8"
 - 9 Flat Washers, 1/4"
 - 9 Lock Washers, 1/4"

1. Remove the crate and packing material from the band saw except for the transport skid on the bottom.
2. Move the saw to its permanent working location. The site should be dry, well lit, and have enough room to handle long stock and the service or adjustment of the machine from any side.
3. Move the band saw off the skid.
4. Clean all rust protected surfaces with a mild solvent or kerosene and a soft cloth. Do not use lacquer thinner, paint thinner, or gasoline. These will damage painted surfaces.
5. For greater stability, the band saw can be secured to the floor with lag screws (not provided) through the four holes in the base.

Tools Required for Assembly & Adjustments

- 1 10mm Open End Wrench (provided)
- 2 14mm Open End Wrenches (not provided)
- 1 Cross Point Screw Driver (not provided)
- 1 Combination Square (not provided)
- 1 6mm hex wrench (not provided)



8.0 Assembly

8.1 Handwheel

Attach the handle (A, Fig. 4) to the handwheel (B, Fig. 4).

8.2 Mounting the Table

Important: The table is heavy. The assistance of a second person is strongly recommended.

Referring to Figures 5 and 6:

1. Remove the table *insert* (A) and *tapered pin* (B).
2. Slide the table so the *saw blade* (D) passes through the *slot* where the *tapered pin* (B) was located.
3. Rotate the table 90 degrees so that the miter slot (C) is parallel to the blade (D) and to the right of the blade when facing the band saw as viewed in Figure 6.
4. Line up the *table* (H) to the trunnions so that the *bolts* (F) feed through the *support brackets* (E). Secure the table with two *lock knobs* (G). Reinstall the table *insert* (A) and *tapered pin* (B).

8.3 Rail Assembly

Referring to Figure 7:

1. Attach the *front rail* (J) to the cast iron table with two 1/4" x 5/8" *hex cap screws*, two 1/4" *lock washers*, and two 1/4" *flat washers*. The screws should be in approximately the center of the slot. Hand-tighten only at this time.
2. Attach the *rear rail* (K) to the table with two 1/4" x 5/8" *hex cap screws*, two 1/4" *lock washers*, and two 1/4" *flat washers*. Screws should be in approximately the center of the slot. Hand-tighten only at this time.
3. Push the front and rear rails *up* as far as they will go.
4. Using a 10mm wrench, tighten the four hex cap screws holding the front and rear rails to the table. Do not over-tighten the screws.
5. Attach the *guide tube* (L) to the front rail with five 1/4" x 5/8" *hex cap screws*, five 1/4" *lock washers*, and five 1/4" *flat washers*. Screws should be in approximately the center of the slot.

Only hand-tighten the guide tube at this time. You will be instructed to secure it later in the *Fence Assembly and Adjustment* section.

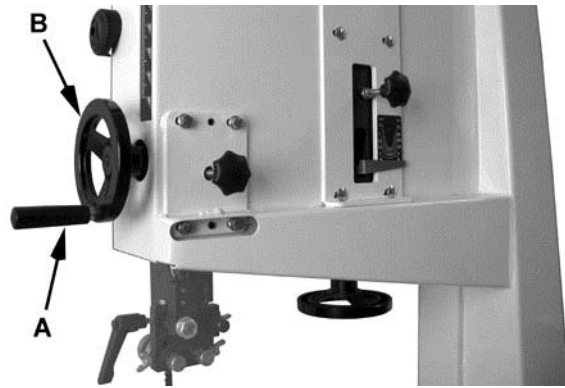

Figure 4

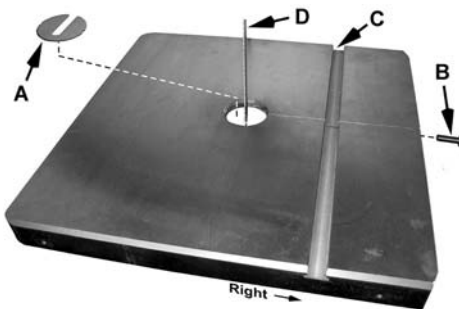

Figure 5

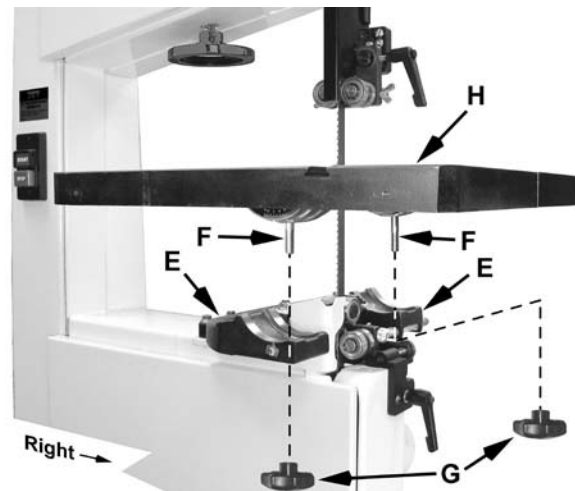

Figure 6

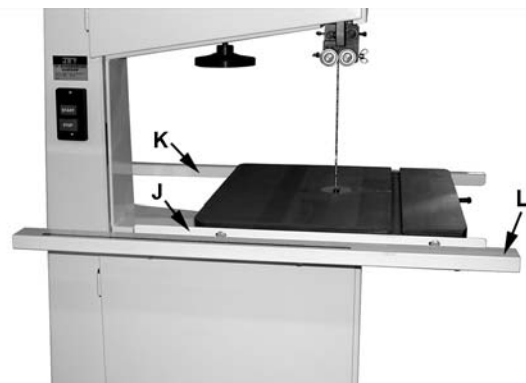

Figure 7

8.4 Chip Tray

Referring to Figure 8:

Insert two 1/4" x 1/4" pan head screws through the holes in the rear rail and into the table edge, leaving the screw heads protruding slightly. Mount the chip tray onto the screws as shown.

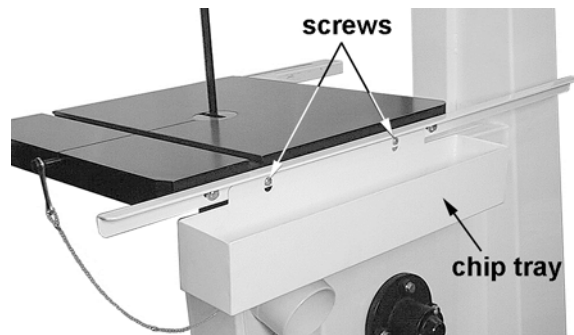

Figure 8

8.5 Dust Collection

If cutting wood on the band saw, attach the hose of a proper dust collection system to the 4" port at the rear of the band saw. NOTE: Dryer vent hose is not acceptable for this purpose.

CAUTION If using the bandsaw for metal working, DO NOT connect a dust collection system designed for wood dust. Hot metal shavings can pose a fire risk.

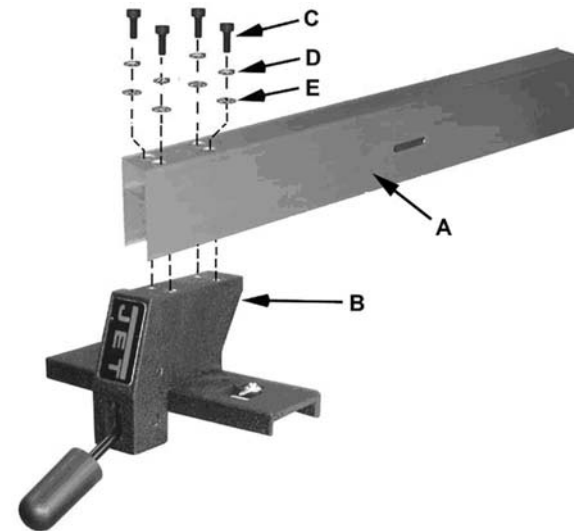

Figure 9

8.6 Fence Assembly and Adjustment

Assembling the Fence to Fence Body

Referring to Figure 9:

1. Attach the fence (A) to the fence body (B) with four 5/16" x 3/4" socket head cap screws (C), four 5/16" lock washers (D), and four 5/16" flat washers (E). Hand-tighten only at this time.

Assembling the Rear Hook

Referring to Figure 10:

2. Thread a 1/4"-20 hex nut (B) onto the pad's threaded stud (A) and insert through the fence (C) so the threaded stud is now inside the fence.
3. Place the rear hook (D) on the threaded stud.

Finish the assembly by placing a 1/4" flat washer (E), 1/4" lock washer (F) and 1/4" hex nut (G) on the threaded stud, and finger tighten.

Note: Adjust for a gap of approximately 1/8" between the pad (A) and hook (D) and as shown in the inset.

4. Tighten the assembly using two 10mm wrenches.

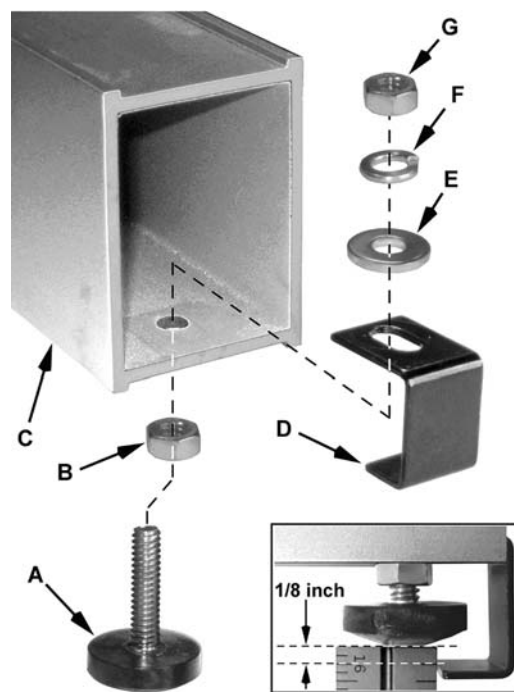

Figure 10

Fence Adjustment

5. Place the fence assembly onto the *guide rail* (D, Figure 11) and against the edge of the *miter slot* (C, Figure 11). The hook at the rear of the fence should fit under the rear rail (see Figure 14).

The fence must align parallel to the miter slot along the entire length of the fence.

If adjustment is necessary:

6. Lock the fence by pushing down the *lock handle* (A, Figure 11). Because the screws are only hand-tight, you can shift the fence slightly as needed until the fence is parallel to the miter slot.
7. When the fence has been properly aligned to the miter slot, tighten the four *socket head cap screws* (B, Figure 11) with a 6mm hex wrench. Make sure the fence remains parallel to the miter slot as you tighten the screws.

Note: This alignment will again be checked once the guide rail has been tightened.

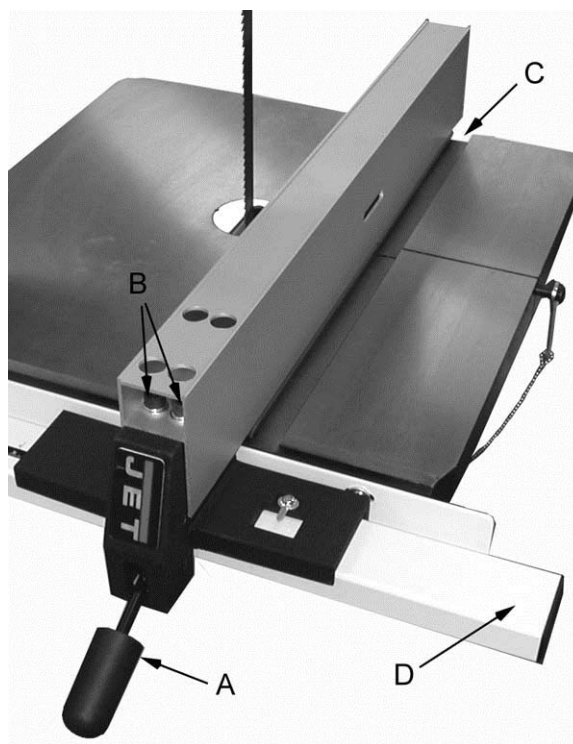

Figure 11

8. Move the fence assembly to the other side of the blade as shown in Figure 12 so that the *pointer* (B, Figure 12) on the fence body points to zero on the scale. Lock the fence by pushing down the *handle* (A, Figure 12).

9. Move the guide rail (D, Figure 12) with the *locked fence* until the fence is flush against the blade (C, Figure 12). Do not unlock the fence to perform this. Move the fence and guide rail together when establishing the zero point.

Important: Do not force the fence into the blade so that the blade bends.

10. With a 10mm wrench, tighten the five hex cap screws located on the bottom of the front rail that hold the guide rail to the front rail.

Note: After tightening the guide rail, double check that the fence is still parallel to the miter slot. Make additional adjustments if needed.

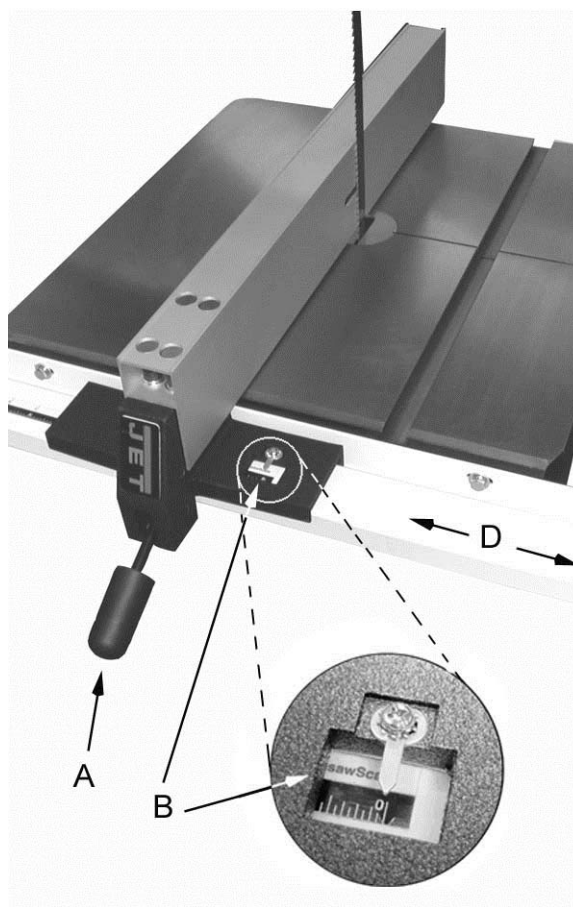

Figure 12

Adjusting Clearance between Fence and Table

Referring to Figures 13 and 14:

Check the clearance between the table and the fence. The fence should not rub against the table surface but be slightly above it. This gap should be the same at the front of the table as it is at the rear.

If the gap between fence and table is not consistent, loosen either of the *hex nuts* on the *hook* (Figure 14) and rotate the *sliding pad* until the fence/table gap is consistent across the full length of the table. When this is achieved, tighten both hex nuts.

Check the adjustment of the *hook* at the rear of the fence. The hook should be positioned so that it overlaps the rear rail by approximately 1/8" (Figure 14). To adjust the hook, loosen the *upper hex nut* and slide the hook in or out as needed. Re-tighten upper hex nut.

8.7 Resaw Guide

For resawing attach the *post* (A, Figure 15) to the fence with the *lock knob* (B, Figure 15). There is a slotted hole in the fence that will accommodate the resaw kit. Position the post so that it is centered with the front edge of the blade. The resaw guide will give you a taller, single point contact surface during resawing.

8.8 Miter Gauge

1. Place the miter gauge in the table slot.
2. With a square verify the miter gauge face is square to the blade.
3. If the miter gauge is not square to the blade loosen the lock knob (C, Figure 15) and adjust to the proper setting. Tighten the lock knob.
4. If the pointer is not at 90 degrees, loosen the screw (D, Figure 15) holding the pointer and move the pointer to 90 degrees.
5. Re-tighten the screw.

9.0 Adjustments

9.1 Table Tilt

1. Disconnect machine from power source.
2. Loosen the lock knobs (G, Figure 16).
3. Tilt table up to 45 degrees to the right, or up to 10 degrees to the left.
4. Tighten the lock knobs.

Note: Table stop bolt (F, Figure 16) must be removed to tilt table to the left.

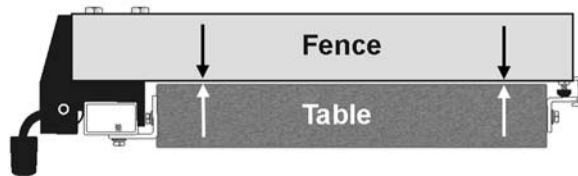

Figure 13

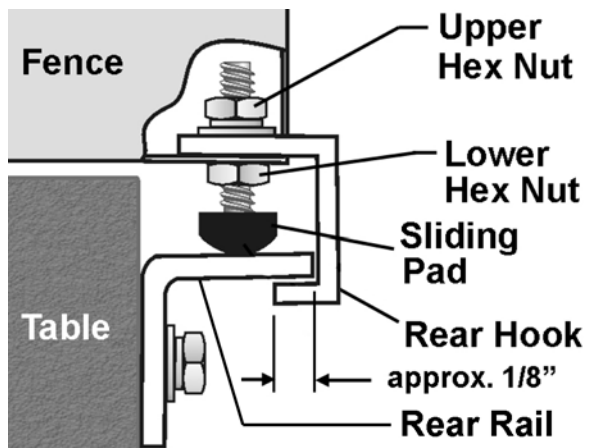

Figure 14

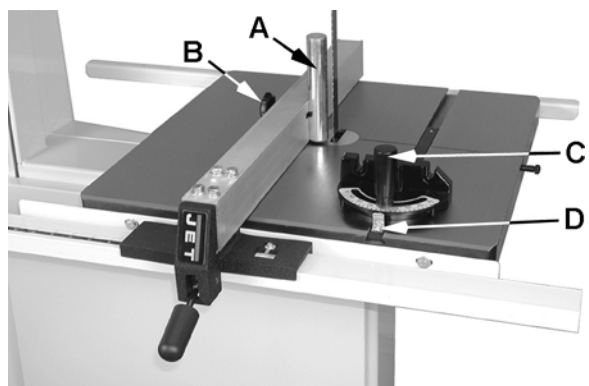

Figure 15

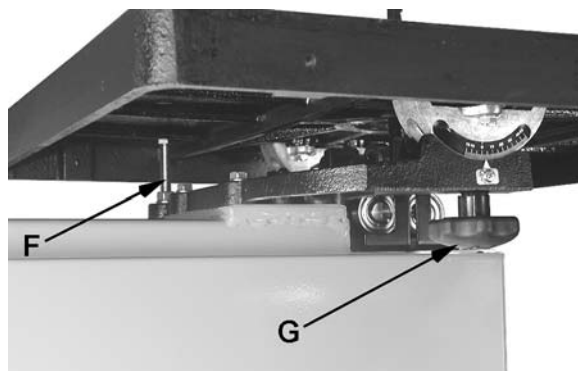

Figure 16

9.2 Adjusting 90 Degree Table Stop

Referring to Figures 17 and 18:

Blade tension must be properly adjusted prior to adjusting 90 degree stop. Refer to the *Adjusting Blade Tension* section.

1. Loosen *lock knobs* (C) and tilt the table until it rests against the table stop bolt (B); then re-tighten the *lock knobs*.
2. Use a *square* (E) placed on the table and against the blade to see if the table is 90 degrees to the blade.
3. If an adjustment is necessary, loosen the *lock knobs* (C). Tilt the table until it is square to the blade; then re-tighten the lock knobs.
4. Loosen *lock nut* (A) and turn table *stop bolt* (B) until it contacts the table. Tighten the *nut* (A) to hold table stop in place. When tightening the nut, hold the table stop bolt in place with a wrench to prevent movement.
5. If necessary, adjust the *pointer* (D) to zero.

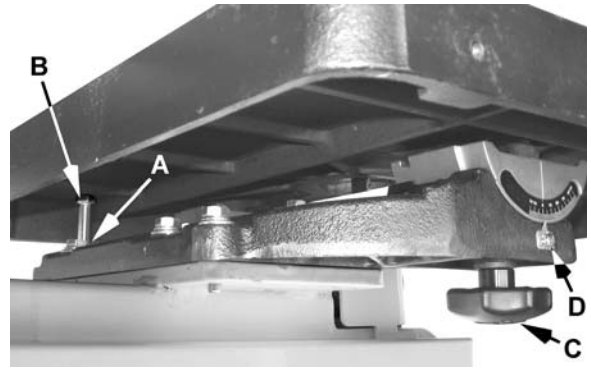

Figure 17

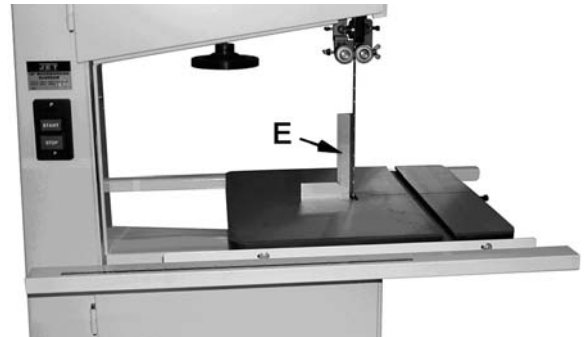

Figure 18

9.3 Speed Adjustments

Make sure the gearbox has lubricant at least halfway up the sight glass (past the indicator mark). Refer to page 23 for further information on oil level and gearbox maintenance.

1. Disconnect band saw from power.
2. To change speeds, loosen the handle (A, Figure 19) and use the lever (B, Figure 19) to lift the gearbox/motor to release tension on the belt. Re-tighten the handle with the gearbox in raised position.
3. Open the lower door on the band saw and move the v-belt to the desired set of pulleys. Figure 20 shows the speeds achieved by the three belt positions.
4. Loosen the handle (A, Figure 19) and lower the gearbox. Set the belt tension by lightly pressing down on the lever (B). The weight of the motor and gearbox should put enough tension on the belt; you just want to push down lightly to take up any slack.
5. Tighten the handle (A).
6. Push in the clutch lever (C, Figure 19) to engage the *high speed* pulley drive; or pull out the clutch lever for *low speed* drive. See Figure 20 for clutch lever position in conjunction with belt positions.

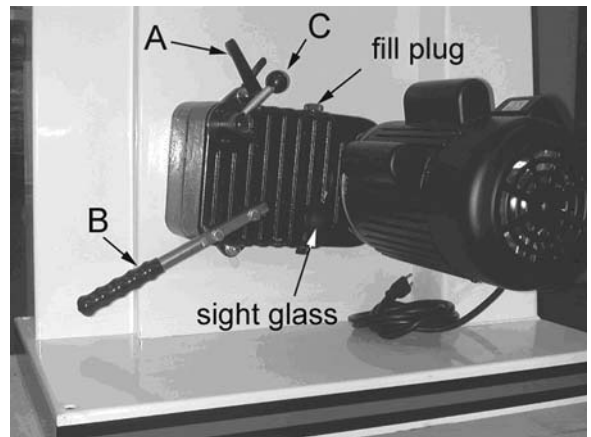

Figure 19

CAUTION Never attempt to shift the clutch mechanism while the saw is running. The saw must be turned off before the clutch is shifted.

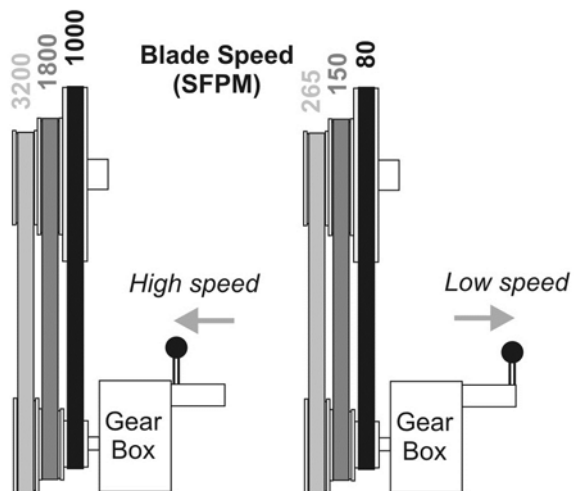

Figure 20

9.4 Installing/Changing Blades

Referring to Figures 21 and 22:

The band saw is provided with a 10-TPI *metal cutting blade*, 137”L x 3/4”W x 0.025”Thk.

⚠WARNING Disconnect machine from power source. Blade teeth are sharp, use care when handling the blade. Failure to comply may cause serious injury.

1. Disconnect machine from power source.
2. Decrease blade tension by rotating the *blade tension handwheel* (A) according to the arrow direction until the handwheel stops.
3. Remove the *table insert* (B).
4. Remove the *tapered pin* (C) by using the wrench attached with the pin together.
5. Lower the *upper blade guide assembly* (H) by loosening the *knob* (F) and rotating the *handwheel* (G).
6. Open *upper and lower front doors* (D).
7. Carefully remove the blade from between upper and lower blade guides; then remove the blade from the upper and lower wheels.
8. Guide new blade through *table slot* (E). Place blade in upper and lower blade guides.

Note: Make sure blade teeth point down toward table (see inset, Figure 21), and toward the front of the saw.

Hint: If the teeth cannot be made to point down, try turning the blade inside out first, then re-attempt.

9. Position blade on the middle of the upper and lower wheels.
10. Replace the *table insert* (B) and *tapered pin* (C).

Before operating the band saw, the new blade must be adjusted and blade guides re-adjusted. The required adjustments are contained in the sections listed below and which follow immediately:

- Blade Tension (page 15)
- Blade Tracking (page 15)
- Upper Bearing Adjustment (page 16)
- Lower Bearing Adjustment (page 17)

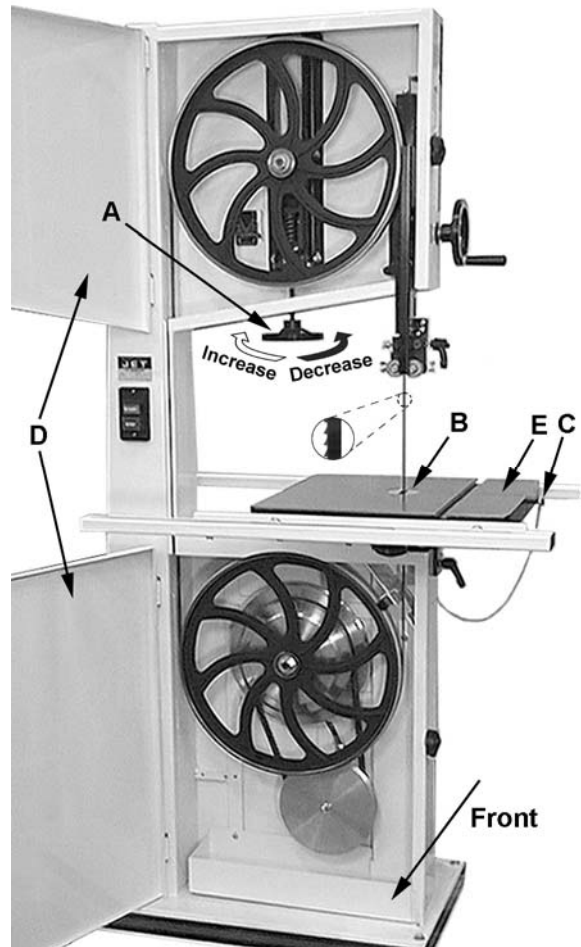

Figure 21

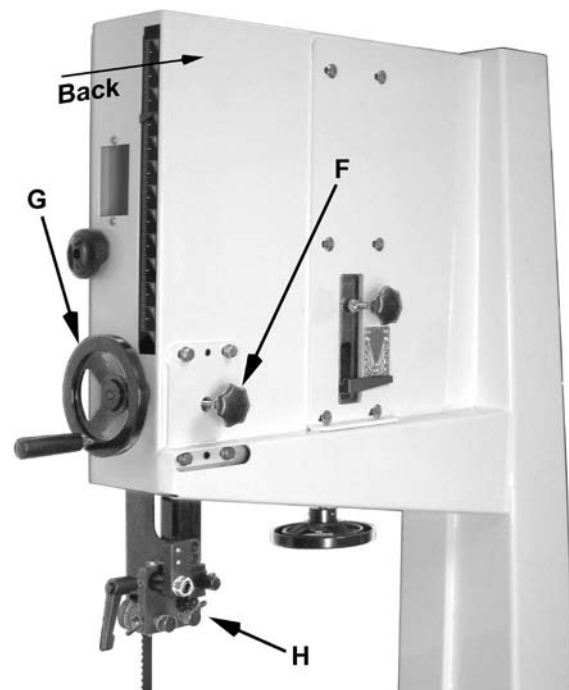

Figure 22

9.5 Blade Tension

Blade tension is set with the *blade tension handwheel* (A, Figure 23) and is performed following blade replacement and periodically as the blade stretches from use.

⚠WARNING Disconnect machine from power source before making any adjustments.

Referring to Figure 23:

1. Set the blade tension by rotating the handwheel according to the *arrow directions* in Figure 23.
2. The *gauge* (B) indicates the approximate tension according to the width of the blade in inches. Initially, set the blade tension to correspond to the width of your blade. The VBS-18MW comes with a 3/4" metal working blade, so the tension should be set at 3/4" on the metal working scale when using this blade.

Note: A tension gauge can also be seen from the front of the saw through the wheel when the upper door is open.

As you become familiar with the saw, you may find it necessary to change the blade tension from the initial setting.

Keep in mind that too little or too much blade tension can cause blade breakage and/or poor cutting performance.

Tip: When the band saw is not being used, slightly release the tension on the blade – this will prolong the blade's life. Make a note of the specific tension setting for that particular blade, as shown on the *gauge* (B). The tension can then be re-set quickly when band saw operations are resumed.

9.6 Blade Tracking

Tracking refers to the position of the saw blade on the wheels while the machine is in operation. Tracking has been factory-adjusted. However, it should be checked occasionally including after every blade change.

⚠WARNING Disconnect machine from power source before making any adjustments.

Important: The blade must be properly tensioned *before* adjusting blade tracking (see previous section). Make sure the blade guides and other parts of the machine will not interfere with the movement of the blade.

To inspect and adjust tracking, proceed as follows:

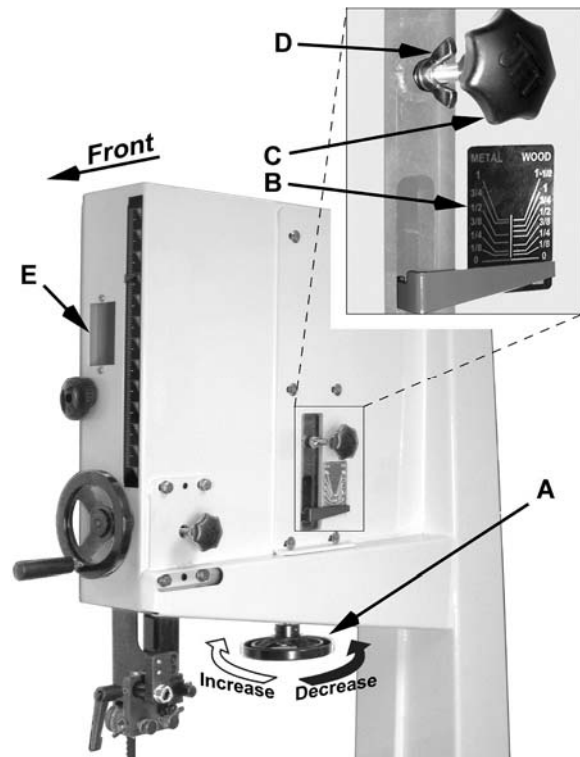

Figure 23

1. Open upper front door to expose the wheel. Rotate the wheel clockwise by hand and observe the position of the blade on the wheel through the window (E). The blade should ride upon the center of the wheel (Figure 24).
 2. If the blade tends to move toward the edge of the wheel, loosen the *wing nut* (D) and slightly rotate the *knob* (C). Rotating the knob clockwise will cause the blade to move toward the rear edge of the wheel. Rotating the knob counterclockwise will cause the blade to move toward the front edge of the wheel.
- Note:** This adjustment is sensitive; perform it in small increments and give the blade time to react to the changes as you continue to rotate the wheel.
3. When the blade is tracking properly in the center of the wheel, re-tighten the *wing nut* (D).
 4. Close the upper front door.

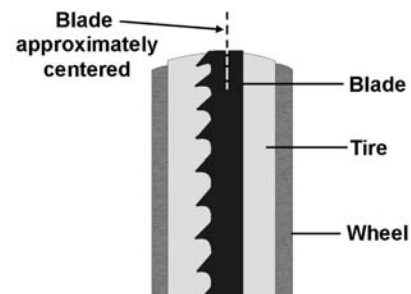

Figure 24

9.7 Overview – Bearing Adjustments

A *Thrust* (back support) *bearing* is located behind the saw blade and provides support to the back of the blade when the saw is in operation.

Guide bearings are located on either side of the saw blade and provide stability for the blade when the saw is in operation. These bearings rotate on an eccentric shaft so the distance from the blade can be adjusted for optimal performance.

9.8 Upper Bearing Adjustments

⚠WARNING Unplug the machine from power source before making any adjustments! Blade teeth are sharp – use care when working near the saw blade. Failure to comply may cause serious injury.

Note: Blade tension must be properly adjusted prior to bearing guide setup. Refer to the *Blade Tension* section.

To adjust the thrust bearing (while referring to Figure 25):

1. Loosen the *thumb screw* (E) and slide the bearing and bearing post until the space between the *thrust bearing* (H) and the back edge of the *blade* (G) is approximately 1/64".

A convenient way to achieve this spacing is by placing a dollar bill folded twice (four thicknesses) between the blade and support bearing – four thicknesses of a dollar bill is approximately 1/64".

To adjust the guide bearings (refer to Figure 26):

2. Loosen the *locking handle* (L) and slide the assembly until the front of the *guide bearings* rest just behind the *gullet* of the blade teeth (see inset).
3. Loosen two *wing nuts* (J₁, J₂). Rotate the *adjustment handles* (M) until the *guide bearings* (K) rest lightly against the *blade* (G). Do not force the guide bearings against the side of the blade.
4. Tighten *wing nuts* (J₁, J₂).

Check to make sure that the adjustments have not changed during tightening, and that the bearing guides do not pinch the blade.

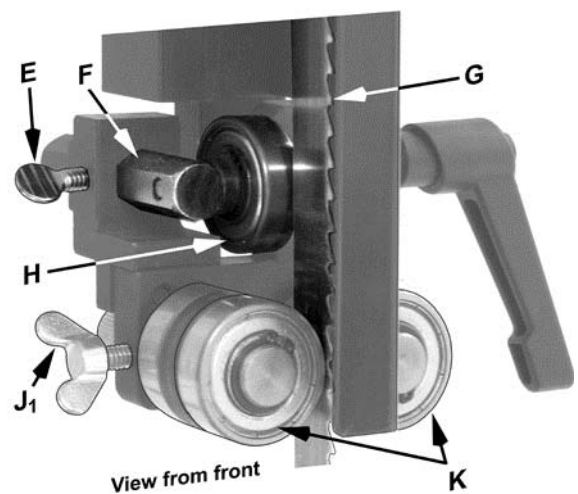

Figure 25

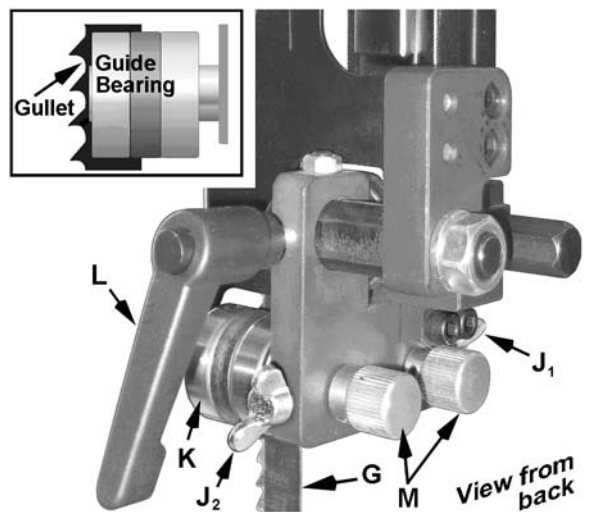

Figure 26

9.9 Lower Bearing Adjustments

⚠WARNING Unplug the machine from power source before making any adjustments! Blade teeth are sharp – use care when working near the saw blade. Failure to comply may cause serious injury.

Note: Blade tension must be properly adjusted prior to bearing guide setup. Refer to the *Blade Tension* section.

Referring to Figure 27:

1. Loosen the *thumb screw* (B).

This will allow the *thrust bearing* (A) to move freely and prevent interference with the *saw blade* (C) during the following steps.

Guide Bearings Adjustment

2. Loosen the *locking handle* (D) then turn the *adjustment screw* (E) to adjust the assembly forward or backward until the front of the *guide bearings* (F) rest just behind the *gullet* of the blade teeth (see inset).

3. Tighten the *locking handle* (D).

Thrust Bearing Adjustment

4. With the *thumb screw* (B) still loose (from Step 1), slide the *thrust bearing* (A) and *bearing post* until the space between the *bearing* (A) and the back edge of the *blade* (C) is approximately 1/64".

A convenient way to achieve this spacing is by placing a dollar bill folded twice (four thicknesses) between the blade and support bearing – four thicknesses of a dollar bill is approximately 1/64".

5. Tighten the *thumb screw* (B).
4. Loosen the *lock knob* (G). Rotate the *adjustment handles* (H) until the *guide bearings* (F) rest lightly against the *blade* (C). *Do not force* the guide bearings against the side of the blade.
5. Tighten the *lock knob* (G).

Check to make sure that the adjustments have not changed during tightening, and that the bearing guides do not pinch the blade.

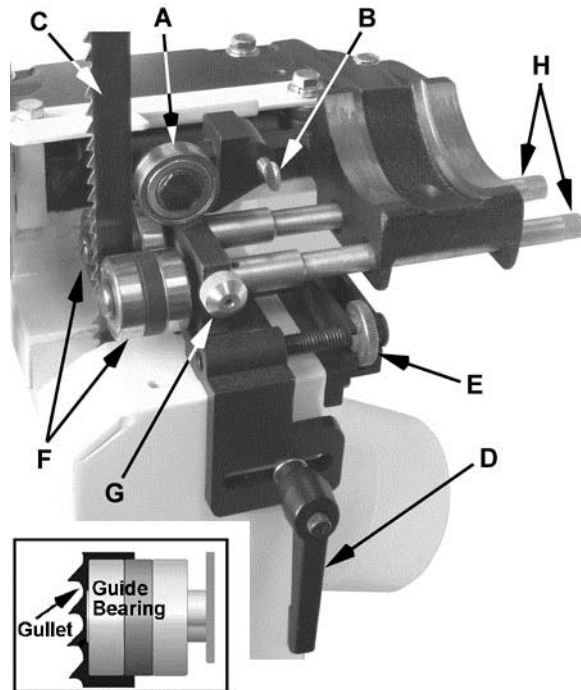

Figure 27

9.10 Blade Lead

Blade drift (also known as *lead* or *fence drift*) is a problem that may occur when the blade begins to wander off the cutting line even when the band saw fence is being used. Figure 28 shows an example of blade lead.

Blade lead can be caused by a number of factors, and these should all be checked and corrected if necessary:

- Fence is not parallel to miter slot and blade.
- Blade is not tensioned correctly.
- Blade is dull.
- Teeth have too much “set” on one side of the blade.

If replacement of the blade is not currently an option, the blade lead can be compensated for by skewing the fence. Proceed as follows:

1. Cut a scrap piece of wood about the same length as the band saw table, and joint one edge along its length, or rip it on a table saw to give it a straight edge.
2. Draw a line on the board parallel with the jointed, or straight edge of the board.
3. Move the band saw fence out of the way, and carefully make a freehand cut along your drawn line on the board. Stop about midway on the board, and shut off the band saw (allow the blade to come to a complete stop) but do not allow the board to move.
4. Clamp the board to the table.
5. Slide the band saw fence over against the board until it contacts the straight edge of the board at some point. Lock the fence down.
6. Loosen the four hex cap screws at the top of the fence (see Figure 11) and shift the fence until it is parallel to the board along its length.
7. Re-tighten the four hex cap screws.

Note: Skewing the fence to correct blade lead is effective for that particular blade; when a new blade is installed, the fence will probably need re-adjustment.

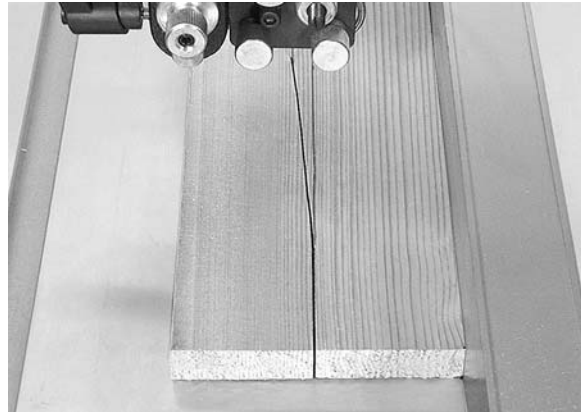

Figure 28

9.11 Replacing the V-Belt

⚠WARNING Disconnect machine from power source before making any adjustments.

Referring to Figures 29 and 30:

1. Release blade tension as described in the *Blade Tension* section.
2. Release belt tension by loosening the *handle* (A) and lifting up on the *lever* (B). Re-tighten the handle.
3. Open the lower wheel *door* (D) and remove the *hex nut* and *washer* (E).
4. Remove the *wheel* (F). If the lower wheel does not come off easily you may need to use a pulley puller to remove it.

Note: If you are doing a pulley alignment *only*, skip Step 5.

5. Remove the *old belt* (G) and install the new belt.
6. Since the wheel is still off, this is the most convenient time to check the wheel and motor pulley alignment. Jump to the *Pulley Alignment* procedure (following page) at this time. At the conclusion you will be re-directed back here.
7. Re-install the lower wheel, hex nut and washer and tighten the hex nut.
8. Lower motor/gearbox (B) and tighten the handle (A).

Important: Before operating the band saw, refer to the sections listed below and perform the required adjustments described in them.

- Installing/Changing Blades (page 14)
- Belt Tension (below)
- Blade Tension (page 15)
- Blade Tracking (page 15)
- Upper Bearing Adjustments (page 16)
- Lower Bearing Adjustments (page 17)

9.12 Belt Tension

The drive belt and pulleys are properly adjusted at the factory. However, belt tension should be occasionally checked. The belt will need to be re-tensioned after belt replacement.

⚠WARNING Disconnect machine from power source before making any adjustments.

1. Release belt tension by loosening the handle (A, Figure 29).

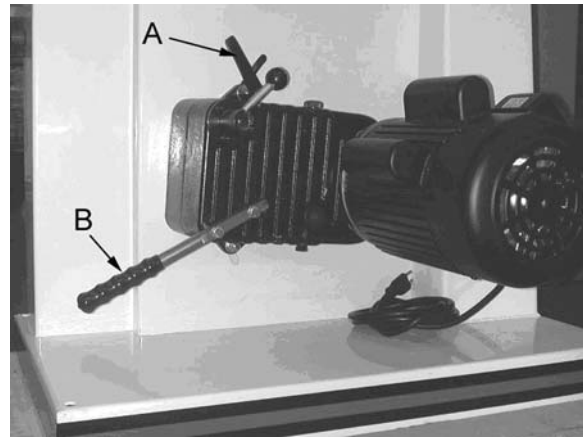

Figure 29

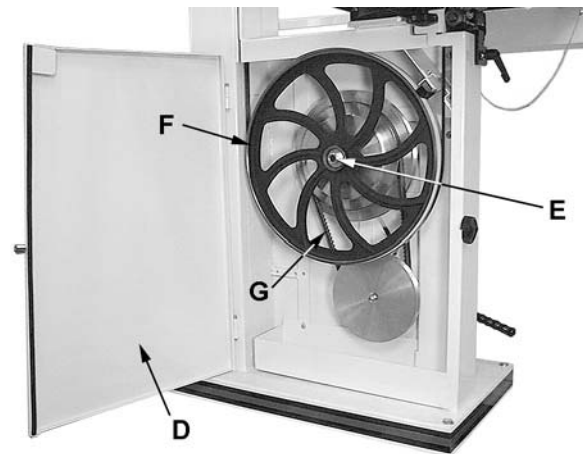

Figure 30

2. Set the belt tension by lightly pressing down on the lever (B, Figure 29). The weight of the motor/gearbox should put enough tension on the belt. You just want to push down lightly to take up any slack.
3. Tighten the handle (A).

Note: A new belt may stretch slightly during the “breaking in” process, and the tension may occasionally need to be checked and adjusted.

9.13 Pulley Alignment

The pulley alignment is done in conjunction with the V-belt replacement.

If you are just beginning the alignment, start with the *Replacing the V-Belt* section (previous page).

If you were directed here, proceed as follows:

1. Use a straight edge placed against the wheel pulley and motor pulley, and refer to Figure 31 to determine if alignment is necessary.

If alignment is necessary:

2. With a 4mm hex wrench, loosen two set screws on the motor (lower) pulley.
3. Adjust the motor pulley by sliding in or out.
4. Confirm the alignment of the V-belt by placing a straight edge against the faces of both pulleys, (Figure 31). If the straight edge lies flush against both pulleys, then the pulleys and belt are aligned.
5. Re-tighten the two set screws on the motor pulley.
6. Return to *Step 7* of the *Replacing the V-Belt* section on page 19.

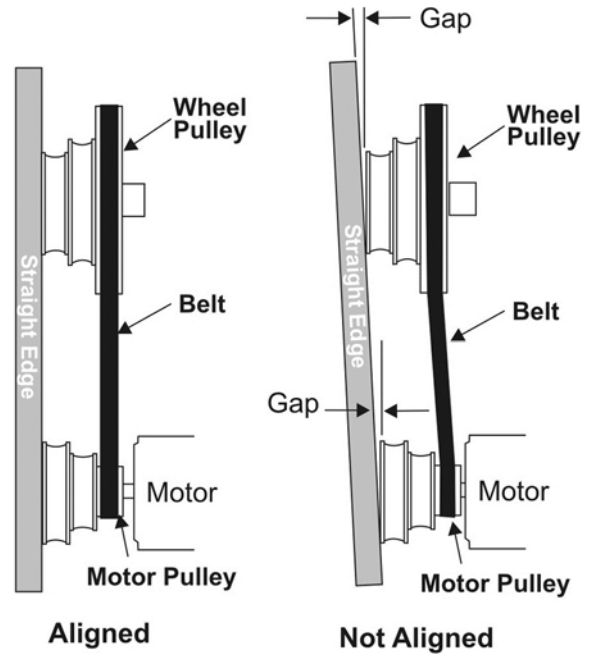

Figure 31

10.0 Electrical Connections

⚠WARNING All electrical connections must be done by a qualified electrician. Failure to comply may result in loss of property and/or serious injury.

VBS-18MW is rated at 1-1/2 HP, 1Ph, 115/230V, prewired 115V.

The band saw comes with a 115V plug. If you switch to 230V, a UL/CSA listed plug needs to be purchased for the band saw that matches the 230V outlet you intend to use.

Confirm that power at the site matches that on the motor plate of the band saw, before making any electrical connections. Review the wiring diagram on page 40.

Review *Grounding Instructions* on pages 6-7.

11.0 Operation

11.1 General Procedure

1. Make sure the blade and upper and lower bearings are properly adjusted for tension and tracking.
2. Adjust blade guide assembly so that the guide bearings are just above the workpiece (about 3/16") allowing minimum exposure to the blade. See Figure 32.
3. If using the fence, move it into position and lock it to the guide rail. If you are using the miter gauge for a crosscut, the fence should be moved safely out of the way.
4. Turn on the band saw and allow a few seconds for the machine to reach full speed.

⚠WARNING Whenever possible, use a push stick, hold-down, power feeder, jig, or similar device while feeding stock, to prevent your hands getting too close to the blade.

5. Place the straightest edge of the workpiece against the fence, and push the workpiece slowly into the blade. Do not force the workpiece into the blade.

⚠CAUTION When cutting, do not overfeed the blade; overfeeding will reduce blade life, and may cause the blade to break.

6. When cutting long stock, the operator should use roller stands, support tables, or an assistant to help stabilize the workpiece.

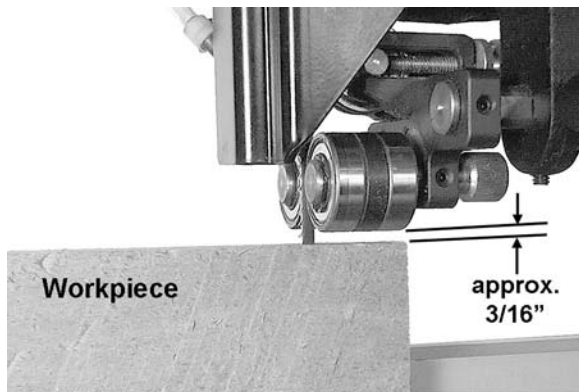

Figure 32

7. When cutting at an angle with a tilted table, provide a guide against which the material being cut can rest. Cutting "freehand" at an angle can result in injury, and maintaining an accurate cut is difficult.

11.2 Ripping

Ripping is cutting lengthwise down the workpiece, and with the grain (of wood stock). See Figure 33.

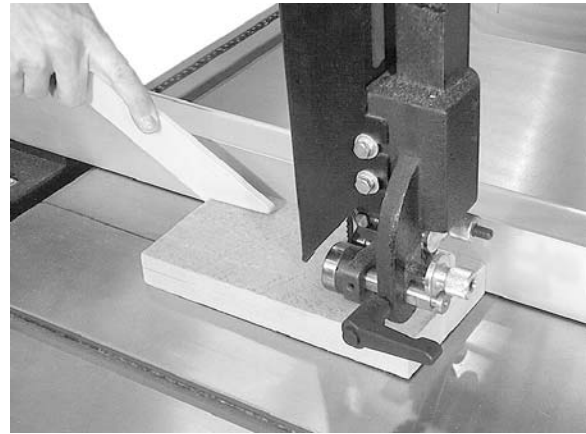

Figure 33

11.3 Crosscutting

Crosscutting is cutting across the grain of the workpiece, while using the miter gauge to feed the workpiece into the blade.

Slide the bar of the miter gauge into the end of the T-slot on the table.

The right hand should hold the workpiece steady against the miter gauge, while the left hand pushes the miter gauge past the blade, as shown in Figure 34.

Do not use the fence in conjunction with the miter gauge. The offcut of the workpiece must not be constrained during or after the cutting process.

⚠CAUTION Using the fence in conjunction with the miter gauge can cause binding and possible damage to the blade.

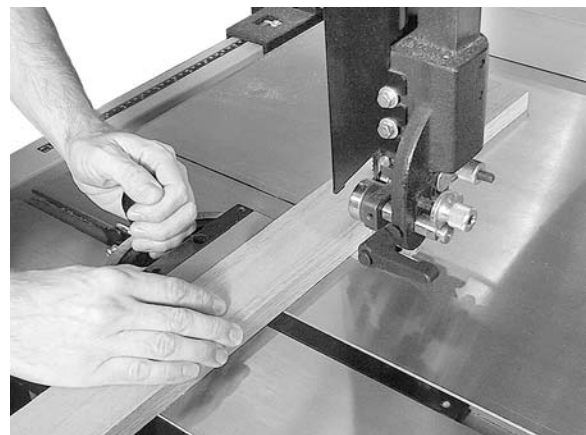

Figure 34

11.4 Resawing

Resawing is the process of slicing stock to reduce its thickness, or to produce boards that are thinner than the original workpiece. Figure 35 demonstrates resawing.

The ideal blade for resawing is the widest one the machine can handle, as the wider the blade the better it can hold a straight line.

When resawing thin stock, use a push block, push stick, or similar device to keep your hands away from the blade.

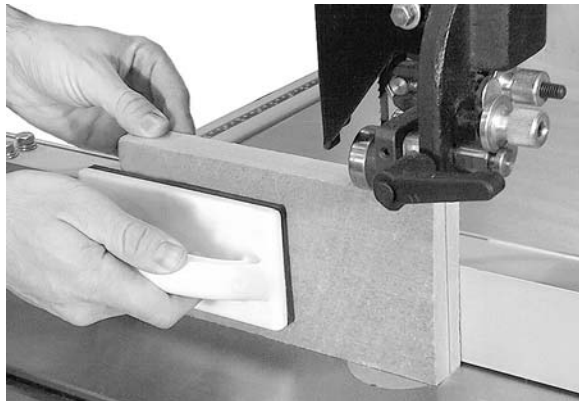

Figure 35

11.5 Saw Blade Selection

Using the proper blade for the job will increase the operating efficiency of your band saw, help reduce necessary saw maintenance, and improve your productivity. Thus, it is important to follow certain guidelines when selecting a saw blade.

Here are factors to consider when selecting a blade:

- The type of material you will be cutting.
- The thickness of the workpiece or part.
- The features of the workpiece or part, such as bends or curves with small radii.

These factors are important because they involve basic concepts of saw blade design. There are five (5) blade features that are normally changed to meet certain kinds of sawing requirements. They are:

1. width
2. pitch (number of teeth per inch)
3. tooth form (or shape)
4. the "set" of the teeth
5. the blade material itself

Width

Band saw blades come in different standard widths, measured from the back of the blade to

the tip of the tooth. Generally, wider blades are used for ripping or making straight cuts; narrower blades are often used when the part being cut has curves with small radii. When cutting straight lines with a narrow blade, the blade may have a tendency to wander, causing *blade lead*. (refer to the *Blade Lead* section in *Adjustments*).

Pitch

Pitch is measured in "teeth per inch" (TPI). Figure 36 shows blades with different pitches. A fine pitch (more teeth per inch) will cut slower but smoother. A coarse pitch (fewer teeth per inch) will cut rougher but faster. As a rule of thumb, the thicker the workpiece, the coarser will be the blade pitch. If you have to cut a hard or very brittle material, you will probably want to use a blade with a finer pitch in order to get good clean cuts.

General rule: Try to use a blade that will have no fewer than 6 and no more than 12 teeth in the workpiece at any given time.

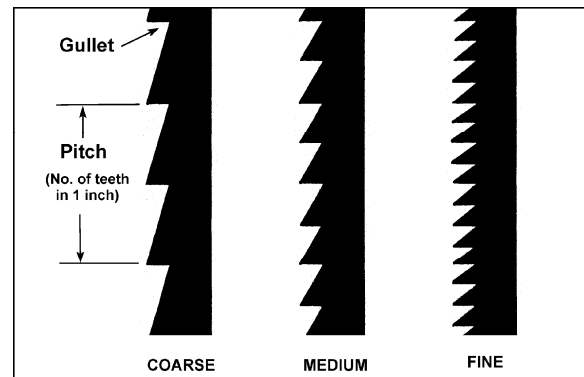

Figure 36

Shape

Figure 37 shows common types of tooth shape. Tooth shape has an effect on cutting rate, and with few exceptions, the Skip and Hook types are used to obtain higher feed rates when cutting thick workpieces. Variable-tooth blades are also available, which combine features of the other styles.

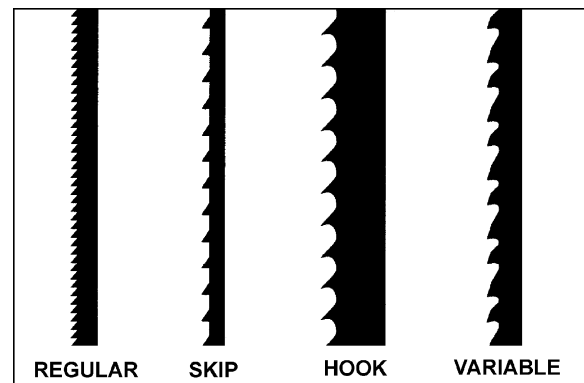

Figure 37

Set

The term "set" refers to the way in which the saw teeth are bent or positioned. Set patterns are usually selected depending on the type of material that needs to be cut. Three common set patterns are shown in Figure 38.

Generally, the Raker set is used for cutting metal workpieces; the Wave set, when the thickness of the workpiece changes, such as cutting hollow tubing or structurals. The Straight set is most often preferred when cutting wood or plastics.

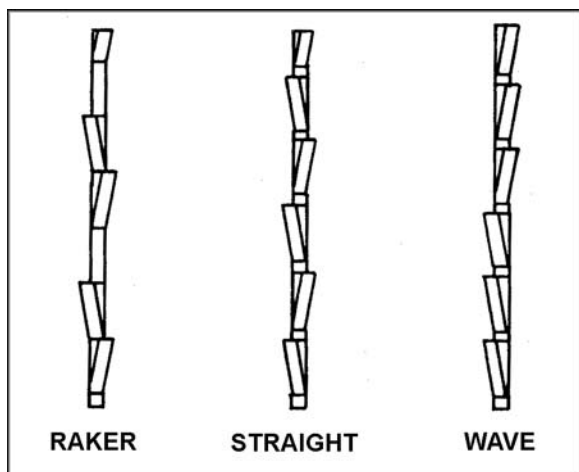

Figure 38

Material

Band saw blades can be made from different types of materials. Some of the most common include spring steel, carbon steel, carbon steel equipped with a high speed or welded edge (bi-metal), or carbide tips. A special type of saw blade is made from "high speed steel"; these should not be used on band saws with low rates of speed.

Because of the importance of blade selection, it is recommended that you use the blade selection guide on page 25. Blades available from your dealer or WMH Tool Group are listed on page 29.

CAUTION When cutting, do not overfeed the blade; overfeeding will reduce blade life, and may cause the blade to break.

11.6 Blade Breakage

Band saw blades are subject to high stresses and breakage may sometimes be unavoidable. However, many factors can be controlled to help prevent most blade breakage. Here are some common causes of breakage:

1. Misalignment of the blade guides.
2. Feeding work too fast.

3. Using a wide blade to cut a short radius curve.
4. Excessive tension.
5. Teeth are dull or improperly set.
6. Upper guides are set too high off the workpiece.
7. Faulty weld on blade.

12.0 Maintenance

WARNING Before any intervention on the machine, disconnect it from the electrical supply by pulling out the plug. Failure to comply may cause serious injury.

Keep bearing guides clean and free of build-up.

Check that the cleaning brush over the band wheel is working properly, and remove any deposits from the band wheels to avoid vibration and blade breakage.

The table surface should be kept clean and free of rust for best results. Some users prefer a paste wax coating. Another option is talcum powder applied with a blackboard eraser rubbed in vigorously once a week; this will fill casting pores and form a moisture barrier. This method provides a table top that is slick and allows rust rings to be easily wiped from the surface. Important also is the fact that talcum powder will not stain wood or mar finishes as wax pickup does.

Do not let saw dust build up in the upper and lower wheel housings. Vacuum out frequently.

Connect the band saw to a JET dust collection system.

Clean and grease the raising/lowering rack for the upper bearing guides if it becomes difficult to raise or lower.

Clean and oil the tensioning mechanism if it becomes difficult to adjust.

Vacuum out the motor fan cover.

Maintain oil level in the gearbox. Before use, pull the pin out of the oil plug. Make sure the gearbox has lubricant at least halfway up the sight glass (past the indicator mark). After the initial 100 hours of use, remove the drain plug beneath the gearbox and drain the oil. Replace the oil plug and fill the gearbox with 90-weight gear oil. After this initial lubrication, the gearbox should be drained and refilled every 2500 hours.

12.1 Replacing Tires

The rubber tires that cover the drive wheels protect the wheel from blade damage and provide a high friction drive force on the tensioned blade. Over a long period of service, the tires wear and may require replacement.

1. Disconnect machine from power source.
2. Remove the blade according to the instructions on page 14.
3. Use a flat screwdriver blade or knife blade to loosen the tires and remove them from the wheels.

4. Clean the surface of the drive wheels. Use a solvent such as mineral spirits as required to achieve a clean, dry surface for the new tires.
5. Carefully slip the replacement tires onto the drive wheels.
6. Re-install the saw blade and re-connect the saw to power.

13.0 Periodic Maintenance

Item	Action	Interval	Maintenance
Saw blade	Listen for sound of missing teeth.	Whenever operating saw	Replace blade when teeth are broken.
	Observe cutting action for cleanness and accuracy.	Whenever operating saw	Replace blade when bent or worn; use a wider blade for more accurate straight cuts.
	Listen for a poor weld – a “click” as it passes through the guide bearings.	When changing blade	Use a different blade or dress the weld with a grinder.
	Watch for signs of slippage on the drive wheels (blade occasionally slows or comes to a stop while sawing).	Whenever sawing	Be sure you are using the correct blade tension; check rubber tires for cleanliness and adherence to drive wheel – replace if necessary.
Lower drive wheel	Check bearing area for leakage of lubricant.	Monthly	Replace bearing if leakage occurs.
Upper drive wheel	Check bearing area for leakage of lubrication.	Monthly	Replace bearing if leakage occurs.
Drive wheel rubber tires	Check for cleanliness.	Daily and when changing blade	Wipe or brush clean.
Drive belt	Check for smooth surfaces and adherence to drive wheel.	Monthly or when blade slippage occurs	Clean when necessary – replace if damaged or excessively worn.
	Check for glazing.	Monthly, or when slippage occurs (squealing belt)	Replace a glazed belt – DO NOT USE BELT DRESSING.
Gearbox	Check sight glass for level – should be to halfway point on sight glass.	Daily	Fill up to halfway point on sight glass with 90 wt. gear oil.
		Annually	Drain and refill.
Blade support bearings	Check for wear, damage or lubricant leakage.	Monthly and when changing blade	Replace when necessary.
Carbide blade guides	Check for excessive wear.	When changing blade	Replace if excessively worn.

14.0 Blade Selection Guide

Identify the material and thickness of your work piece. The chart will show the recommended PITCH, blade TYPE, and FEED RATE.

Key: H – Hook L – Low
 S – Skip M – Medium
 R – Regular H – High

Example: 10/H/M means 10 teeth per inch / Hook Type Blade / Medium Feed

MATERIAL/S		WORKPIECE THICKNESS			
		½"	1"	3"	6+"
WOODS	HARDWOOD	10/R/L	8/R/L	3/H/M	3/H/M
	SOFTWOOD	10/R/L	8/R/L	3/H/M	3/H/M
NON-METALS	CARBON	10/R/L	6/R/L	3/S/M	3/S/M
	MICA	32/R/L	—	—	—
	ASBESTOS	8/R/L	6/R/L	3/S/M	3/S/M
	HARD RUBBER	10/R/L	8/R/L	6/R/M	2/S/H
PLASTICS	FORMICA	14/R/M	10/R/M	4/H/H	4/H/H
	MASONITE	10/R/L	4/S/L	3/S/M	3/H/M
	MICARTA	14/R/M	10/R/M	4/H/H	3/H/H
	PLEXIGLAS	10/R/L	6/R/L	3/S/M	3/S/M
	PAPER	14/R/L	10/R/L	4/S/L	3/S/M

To cut a radius:

Study the part drawing or prototype, or actually measure the smallest cutting radius required, and locate this radius (in inches) on the chart at the right. Follow the curve to where the approximate blade width is specified. If a radius falls between two of the curves, select the widest blade that will saw this radius.

This procedure should be used for making initial blade selections. These recommendations can, of course, be adjusted to meet specific requirements of a cutting job. Compromises may be necessary if you cannot find all needed specifications in a single blade.

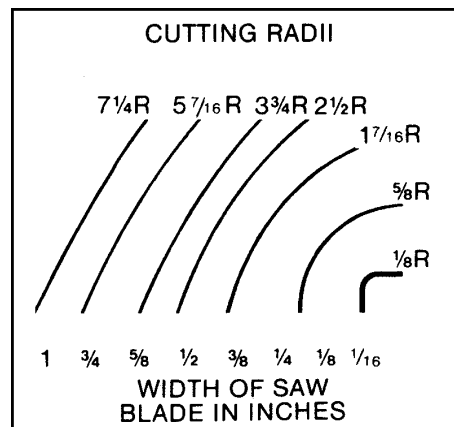

15.0 Blade Speed per Materials Chart

Material being cut	Speed range (SF/M)
Structural steel shapes	165
Low carbon steel	160-165
Medium carbon steel	115
High carbon steel	90-100
Cr-moly steel	105-135
Ni-Cr-moly steel	90-115
Chromium steel	80-140
Cr-vanadium steel	105-115
Tool steel	40-80
Stainless steel	40-70
Free machining steel	80-100
Cast iron	55-90
Copper alloy (CU-Zn)	55
Bronze	90
Al-bronze	40
Monel	40-45
Titanium alloy	25-40
Aluminum (soft)	3000
Aluminum (T-6+)	3000
Carbon	3000
Slate	80-160
PTFE sheet, rod, rounds	3000
Hard rubber	3000
Plywood	3000
Other woods	3000

16.0 Troubleshooting VBS-18MW Band Saw

Trouble	Probable Cause	Remedy
Saw stops or will not start.	Saw unplugged.	Check plug connections.
	Fuse blown, or circuit breaker tripped.	Replace fuse, or reset circuit breaker.
	Cord damaged.	Replace cord.
Does not make accurate 45° or 90° cuts.	Stop not adjusted correctly.	Check blade with square and adjust stop. See sect. 9.2.
	Angle pointer not set accurately.	Check blade with square and adjust pointer. See sect. 9.2.
	Miter gauge out of adjustment.	Adjust miter gauge. See page 12.
Blade wanders during cut; or out-of-square cuts.	Fence not aligned with blade.	Check and adjust fence.
	Warped wood.	Select another piece of wood.
	Gum or pitch on blade or table.	Clean as needed.
	Excessive feed rate.	Reduce feed rate.
	Incorrect blade for cut.	Change blade to correct type. See page 25.
	Inadequate blade tension.	Set blade tension according to blade size.
	Blade guide assembly is loose.	Tighten blade guide assembly.
	Guide bearings not set properly, or are worn.	Review guide bearing adjustment, pages 16-17. If bearings are worn, replace them.
	Dull blade.	Replace blade.
	Incorrect blade speed.	See page 26.
Bad cuts (rough).	Blade speed too high for feed rate.	Reduce blade speed and feed rate.
	Blade is too coarse.	Replace with finer blade (page 25).
Blade does not come up to speed.	Extension cord too light or too long.	Replace with adequate size and length cord. See Figure 3, page 7.
	Low shop voltage.	Contact your local electric company.
Saw vibrates excessively.	Base on uneven floor.	Reposition on flat, level surface.
	Bad v-belt.	Replace v-belt. See page 19.
	Motor mount is loose.	Tighten motor mount hardware.
	Loose fasteners.	Locate source of vibration, and tighten fasteners.

Trouble	Probable Cause	Remedy
Excessive blade breakage.	Material loose in vise.	Clamp work securely.
	Incorrect speed or feed rate.	Refer to charts on pages 25-26 or check Machinist's Handbook for speed/feed appropriate for the material being cut.
	Teeth too coarse for material.	Check Machinist's Handbook for recommended blade type.
	Incorrect blade tension.	Adjust blade tension to point where the blade just does not slip on the wheel.
	Blade rubs on the wheel flange.	Adjust blade tracking. See sect. 8.8.
	Misaligned guides.	Adjust guides (sect. 9.7 thru 9.9).
	Cracking at weld.	Install a fresh blade, or use longer annealing cycle if welding your own.
Premature blade dulling.	Blade teeth too coarse.	Use a finer tooth blade.
	Blade speed too high.	Try a lower blade speed.
	Hard spots in workpiece or scale on/in workpiece.	Increase feed pressure (hard spots). Reduce speed, increase feed pressure (scale).
	Work hardening of material (especially stainless steel).	Increase feed rate.
	Insufficient blade tension.	Increase tension to proper level (sect. 9.5).
	Operating saw without pressure on workpiece.	Do not run blade at idle in/on material.
Blade is twisting.	Blade is binding in the cut.	Decrease feed pressure.
	Blade tension too high.	Decrease tension on blade.
Unusual wear on side/back of blade.	Blade guides worn.	Replace blade guides.
	Blade guide bearings not adjusted.	Adjust blade guide bearings.
	Blade guide bearing bracket is loose.	Tighten blade guide bearing bracket.
Teeth missing/ripped from blade.	Blade tooth pitch too coarse for workpiece.	Use blade with finer tooth pitch.
	Feed rate either too slow or too fast.	Adjust feed rate and/or blade speed.
	Workpiece vibrating.	Clamp workpiece securely.
	Gullets loading up with chips.	Use blade with coarse tooth pitch and/or reduce feed rate. Brush blade to remove chips.

17.0 Replacement Parts

Replacement parts are listed on the following pages. To order parts or reach our service department, call 1-800-274-6848, Monday through Friday (see our website for business hours, www.jettools.com). Having the Model Number and Serial Number of your machine available when you call will allow us to serve you quickly and accurately.

17.1.1 Upper Wheel Assembly

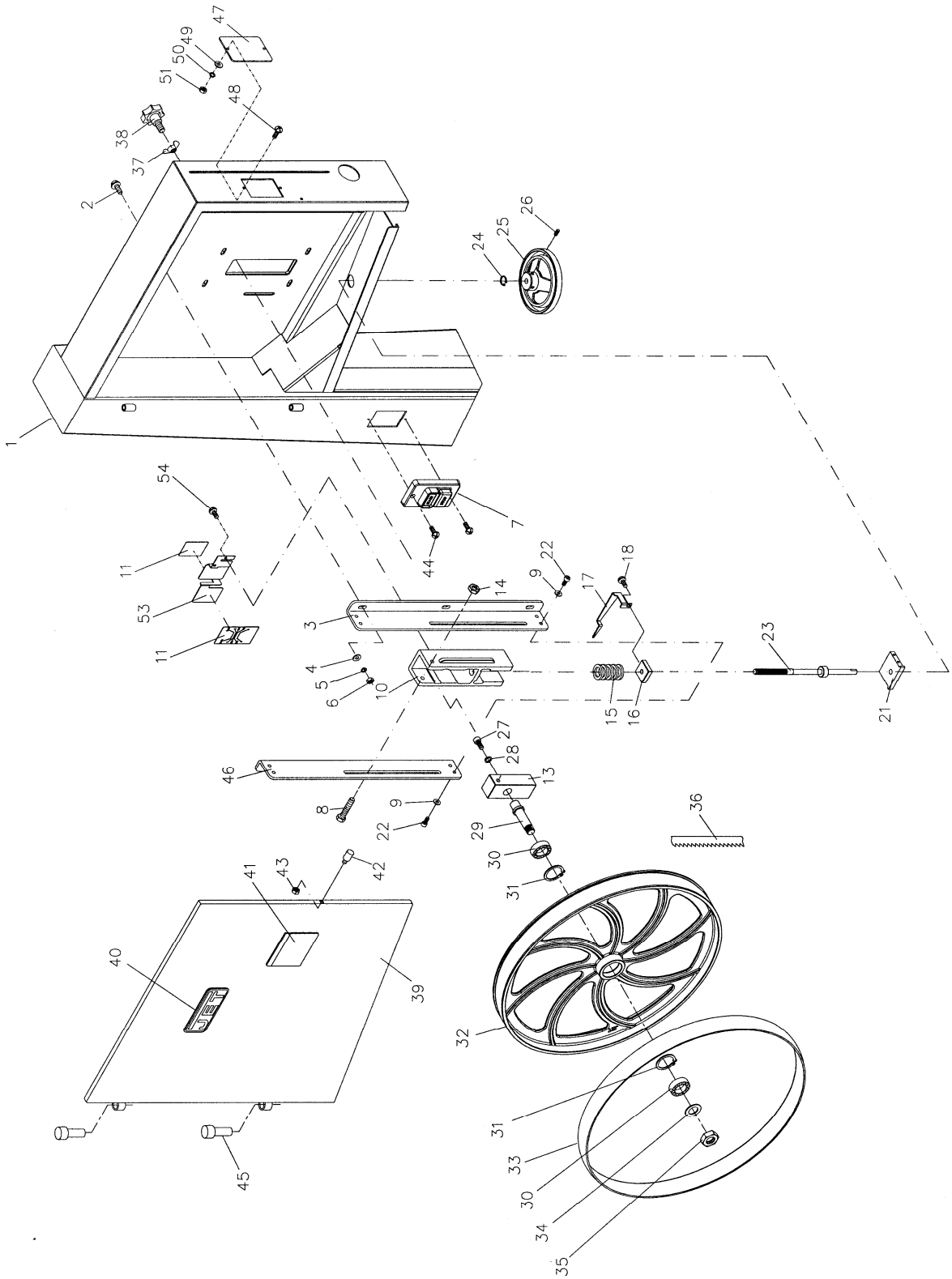

17.1.2 Parts List: Upper Wheel Assembly

Index No.	Part No.	Description	Size	Qty
1	VBS18MW-101G	Saw Body		1
2	TS-0152011	Carriage Bolt	5/16-18x1	6
3	JWBS18DX-103	Upper Wheel Bracket (Right Side)		1
4	TS-0680031	Flat Washer	5/16	6
5	TS-0720081	Lock Washer	5/16	6
6	TS-0561021	Hex Nut	5/16-18	6
7	JWBS18-107	Switch		1
8	TS-1490151	Hex Cap Screw	M8x80	1
9	TS-0680021	Flat Washer	1/4	4
10	JWBS18DX-110	Sliding Bracket		1
11	VBS18MW-111	Blade Tension Indicator		2
13	JWBS18DX-113	Shaft Bracket		1
14	TS-1540061	Hex Nut	M8	1
15	JWBS18-115	Spring		1
16	JWBS18-116	Square Nut		1
17	JWBS18DX-117	Pointer		1
18	JWBS18-118	Screw	M5x8	1
21	JWBS18DX-121	Bracket		1
22	TS-0050021	Hex Cap Screw	1/4-20x5/8	4
23	JWBS18DX-123	Blade Adjusting Screw		1
24	JWBS18-124	E-Ring	E-9	1
25	JWBS18-125	Hand Wheel		1
26	TS-0267041	Set Screw	1/4-20x3/8	2
27	TS-0209021	Socket Head Cap Screw	3/8-16x5/8	1
28	TS-0720091	Lock Washer	3/8	1
29	JWBS18-129	Upper Wheel Shaft		1
30	BB-6203ZZ	Ball Bearing	6203ZZ	2
31	JWBS18-131	Retaining Ring	R40	2
32	JWBS18-132	Upper Wheel		1
33	JWBS18DX-133	Tire		1
34	JWBS18-134	Flat Washer		1
35	JWBS18-135	Hex Nut	5/8-18UNF L.H.	1
36		Blade (<i>local purchase</i>)	137"	1
37	TS-0590061	Wing Nut	5/16-18	1
38	JWBS18-138	Lock Knob	5/16	1
39	JWBS18DX-139G	Upper Front Door		1
40	JET-165	JET Logo with 3M adhesive	165X68mm	1
41	JWBS18-141	Warning Label		1
42	JWBS18-142	Bolt		1
43	TS-0561011	Hex Nut	1/4-20	1
44	TS-081C052	Screw	#10-24x3/4	2
45	JWBS18-39A	Door Hinge Pin		2
46	JWBS18DX-146	Upper Wheel Bracket (Left Side)		1
47	JWBS18DX-147	Tracking Window		1
48	TS-081C032	Screw	#10-24x1/2	2
49	TS-1550031	Flat Washer	M5	2
50	TS-2361051	Lock Washer	M5	2
51	TS-0560071	Hex Nut	#10-24	2
53	JWBS18DX-153G	Scale Bracket		1
54	TS-081C022	Screw	#10-24x3/8	2

17.2.1 Lower Wheel and Motor Assembly

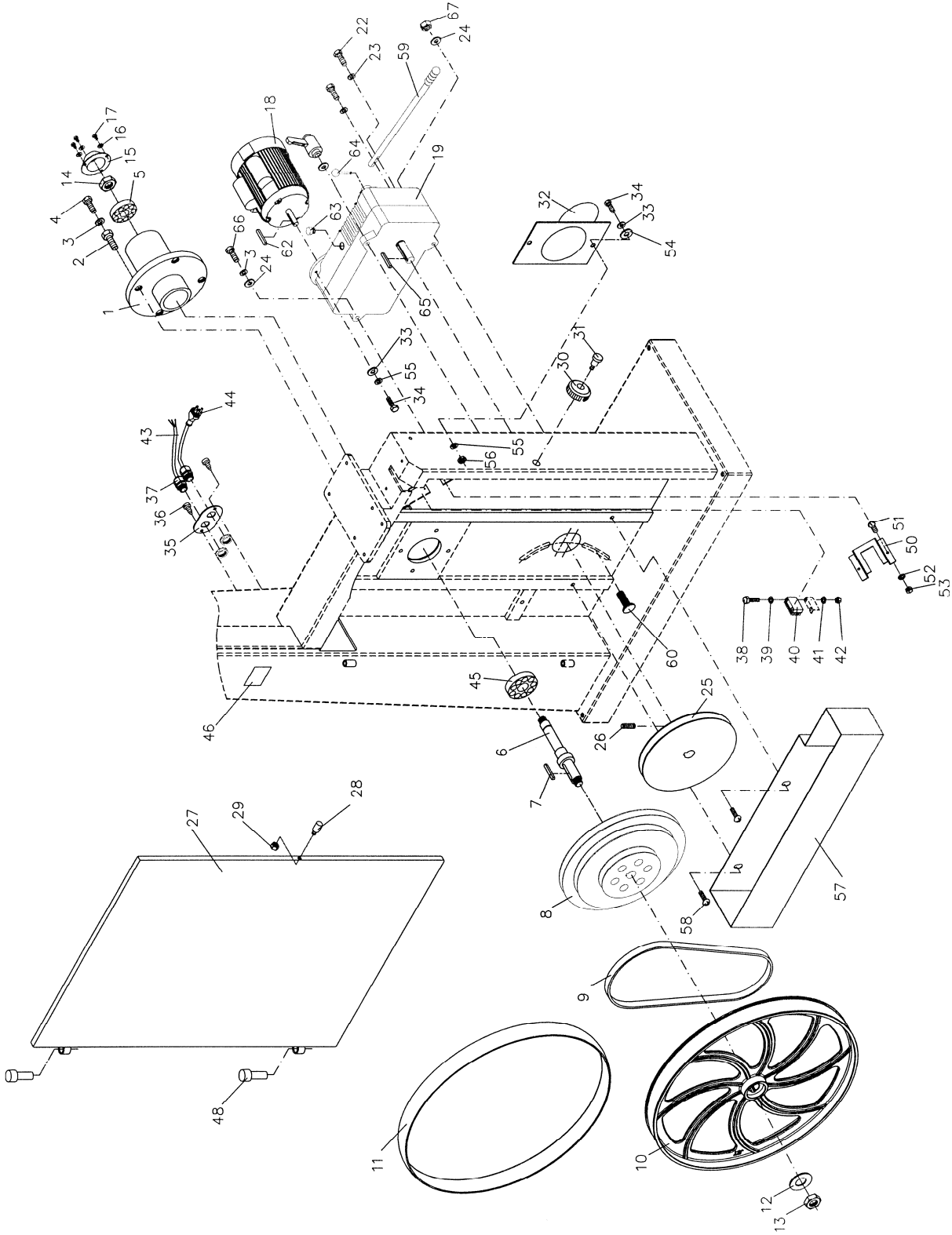

17.2.2 Parts List: Lower Wheel and Motor Assembly

Index No.	Part No.	Description	Size	Qty
1	JWBS18-201N	Bearing Base		1
2	JWBS20-62	Adjusting Bolt		4
3	TS-0720091	Lock Washer	3/8	5
4	TS-0060081	Hex Cap Screw	3/8-16x1-3/4	4
5	BB-6204ZZ	Ball Bearing	6204ZZ	1
6	VBS18MW-206	Spindle		1
7	VBS18MW-207	Key	7x7x65	1
8	VBS18MW-208	Spindle Pulley		1
9	VB-B48	V-Belt	B-48	1
10	JWBS18-210	Lower Wheel		1
11	JWBS18DX-133	Tire		1
12	TS-0680081	Flat Washer	5/8	1
13	JWBS18-135	Hex Nut	5/8-18UNF L.H.	1
14	JWBS18-214	Hex Nut	5/8-18UNF R.H.	1
15	JWBS18-215	Bearing Cover		1
16	TS-0720051	Lock Washer	#10	3
17	TS-081C022	Screw	#10-24x3/8	3
18	VBS18MW-218	Motor	1-1/2HP, 1PH, 115/230V	1
	JWBS18X-MFC	Motor Fan Cover (not shown)		1
	VBS18MW-218MF	Motor Fan (not shown)		1
	VBS18MW-218CS	Centrifugal Switch (not shown)		1
	VBS18MW-218SCC	Starting Capacitor Cover (not shown)		1
	VBS18MW-218RCC	Running Capacitor Cover (not shown)		1
	VBS18MW-218SC	Starting Capacitor (not shown)	200MFD, 125VAC	1
	VBS18MW-218RC	Running Capacitor (not shown)	40µF, 250VAC	1
	VBS18MW-218JB	Junction Box (not shown)		1
	VBS18MW-218JBC	Junction Box Cover (not shown)		1
19	VBS18MW-219	Gear Box Assembly		1
22	TS-0050051	Hex Cap Screw	1/4-20x1	2
23	TS-0720071	Lock Washer	1/4	2
24	TS-0680041	Flat Washer	3/8	3
25	VBS18MW-225	Motor Pulley		1
26	TS-0270031	Set Screw	5/16-18x3/8	2
27	JWBS18DX-227G	Lower Front Door		1
28	JWBS18-142	Bolt		1
29	TS-0561011	Hex Nut	1/4-20	1
30	JWBS20-2	Lock Knob		1
31	TS-081F052	Screw	1/4-20x3/4	1
32	JWBS20-8G	Dust Chute		1
33	TS-0680031	Flat Washer	5/16	6
34	TS-0051051	Hex Cap Screw	5/16-18x1	6
35	JWBS18-235	Plate		1
36	TS-081C032	Screw	#10-24x1/2	2
37	JWBS18-237	Strain Relief Bushing		2
38	TS-081C082	Screw	#10-24x1-1/2	2
39	TS-1550031	Flat Washer	M5	2
40	JWBS18-240	Brush		1
41	TS-2361051	Lock Washer	M5	2
42	TS-0560071	Hex Nut	#10-24	2
43	JWBS18-243	Motor Cord		1
44	JWBS18-244	Power Cord		1
45	BB-6205ZZ	Ball Bearing	6205ZZ	1
46	VBS18MW-246	ID Label		1
48	JWBS18-39A	Door Hinge Pin		2
50	JWBS18DX-250G	Shelf		1

Index No.	Part No.	Description	Size	Qty
51	TS-081C032	Screw	#10-24x1/2	2
52	TS-1550031	Flat Washer	M5	2
53	TS-0560071	Hex Nut	#10-24	2
54	JWBS18DX-254	Plastic Washer	5/16	1
55	TS-0720081	Lock Washer	5/16	6
56	TS-0561021	Hex Nut	5/16-18	2
57	VBS18MW-257G	Lower Chip Tray		1
58	TS-081F032	Pan Head Screw	1/4-20x1/2	2
59	VBS18MW-259	Handle		1
60	TS-0160021	Carriage Bolt	3/8-16x1-1/2	2
61	VBS18MW-261	Lock Handle		1
62	VBS18MW-262	Key	6x6x40	1
63	VBS18MW-263	Plug		1
64	VBS18MW-264	Handle		1
65	VBS18MW-265	Key	6x6x45	1
66	TS-0060091	Hex Cap Screw	3/8-16x2	1
67	TS-0640091	Nylon Lock Hex Nut	3/8-16	1

17.3.1 Blade Guide Assembly

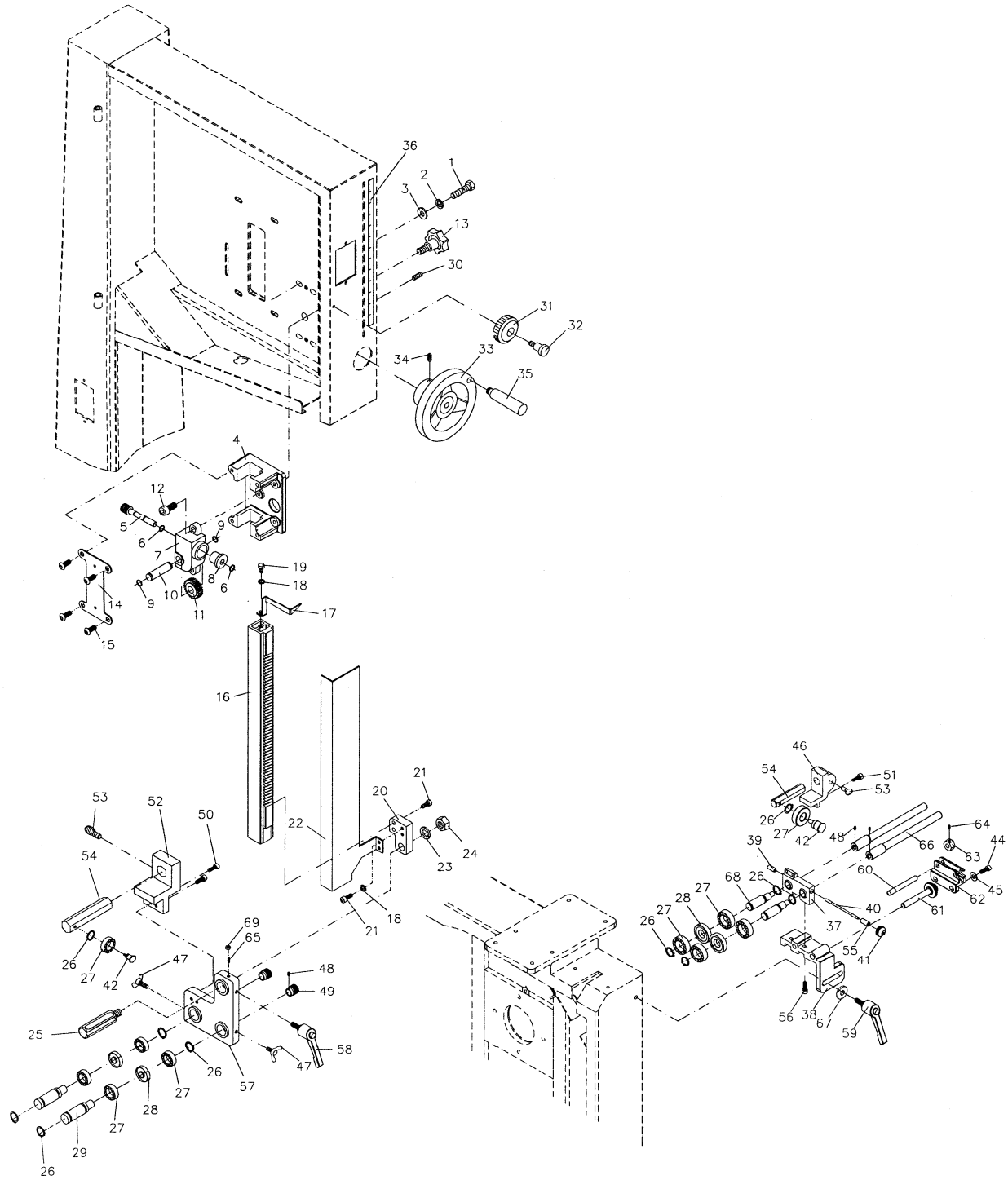

17.3.2 Parts List: Blade Guide Assembly

Index No.	Part No.	Description	Size	Qty
1	TS-0051051	Hex Cap Screw	5/16-18x1	4
2	TS-0720081	Lock Washer	5/16	4
3	TS-0680031	Flat Washer	5/16	8
4	JWBS18DX-304	Guide Bar Bracket		1
5	JWBS18-305	Worm		1
6	JWBS18-306	E-Ring	E-8	2
7	JWBS18-307	Gear Base		1
8	JWBS18-308	Bushing		1
9	JWBS18-309	C-Ring	S-12	2
10	JWBS18-310	Shaft		1
11	JWBS18-311	Gear		1
12	TS-0208071	Socket Head Cap Screw	5/16-18x1-1/4	2
13	JWBS18-313	Lock Knob	5/16	1
14	JWBS18DX-314	Plate		1
15	TS-0255021	Button Head Socket Screw	5/16-18x1/2	4
16	JWBS18DX-316	Guide Bar		1
17	JWBS18DX-317	Pointer		1
18	TS-0720071	Lock Washer	1/4	3
19	TS-0050011	Hex Cap Screw	1/4-20x1/2	1
20	JWBS18-320N	Guide Bracket		1
21	TS-0207021	Socket Head Cap Screw	1/4-20x1/2	4
22	JWBS18X-322R	Blade Guard		1
23	TS-0720111	Lock Washer	1/2	1
24	TS-0561051	Hex Nut	1/2-13	1
25	JWBS18DX-325	Locking Shaft		1
26	JWBS20-326	C-Ring		10
27	BB-6202ZZ	Ball Bearing	6202ZZ	10
28	JWBS20-328	Spacer		4
29	JWBS20-329	Shaft		2
30	TS-0270031	Set Screw	5/16-18x3/8	2
31	JWBS20-2	Lock Knob		1
32	TS-081F052	Screw	1/4-20x3/4	1
33	JWBS18-333	Hand Wheel		1
34	TS-0267041	Set Screw	1/4-20x3/8	1
35	JWBS20-103A	Handle		1
36	JWBS18DX-336	Cutting Height Scale		1
37	JWBS18DX-337	Bracket		1
38	JWBS18DX-338	Base		1
39	JWBS20-339	Threaded Lock Bushing		1
40	JWBS20-340	Bolt		1
41	JWBS18DX-341	Lock Knob		1
42	JWBS20-342	Screw		2
44	TS-0207041	Socket Head Cap Screw	1/4-20x3/4	2
45	TS-0680021	Flat Washer	1/4	2
46	JWBS20-360	Bracket		1
47	JWBS20-324	Wing Screw		2
48	TS-1521011	Set Screw	M4 x 4	8
49	JWBS20-349	Knob		2
50	TS-0207031	Socket Head Cap Screw	1/4-20x5/8	2
51	TS-0207021	Socket Head Cap Screw	1/4-20x1/2	2
52	JWBS20-352	Bracket		1
53	JWBS20-353	Thumb Screw	1/4-20x1/2	2
54	JWBS20-354	Bearing Support		2
55	JWBS20-355	Lock Bushing		1
56	TS-0206021	Socket Head Cap Screw	#10-24x1/2	2

Index No.	Part No.	Description	Size	Qty
57	JWBS18DX-357	Bearing Bracket		1
58	6295293	Locking Handle		1
59	JWBS18DX-359	Locking Handle		1
60	JWBS18DX-360	Shaft		1
61	JWBS18DX-361	Adjusting Screw		1
62	JWBS18DX-362	Adjusting Bracket		1
63	JWBS18DX-363	Nut		1
64	TS-0267021	Set Screw	1/4-20x1/4	1
65	JWBS18DX-365	Set Screw, Special		1
66	JWBS18DX-366	Adjustment Handle		2
67	TS-0680031	Flat Washer	5/16	1
68	JWBS20-329A	Lower Shaft		2
69	TS-0561011	Hex Nut	1/4-20	1

17.4.1 Table and Fence Assembly

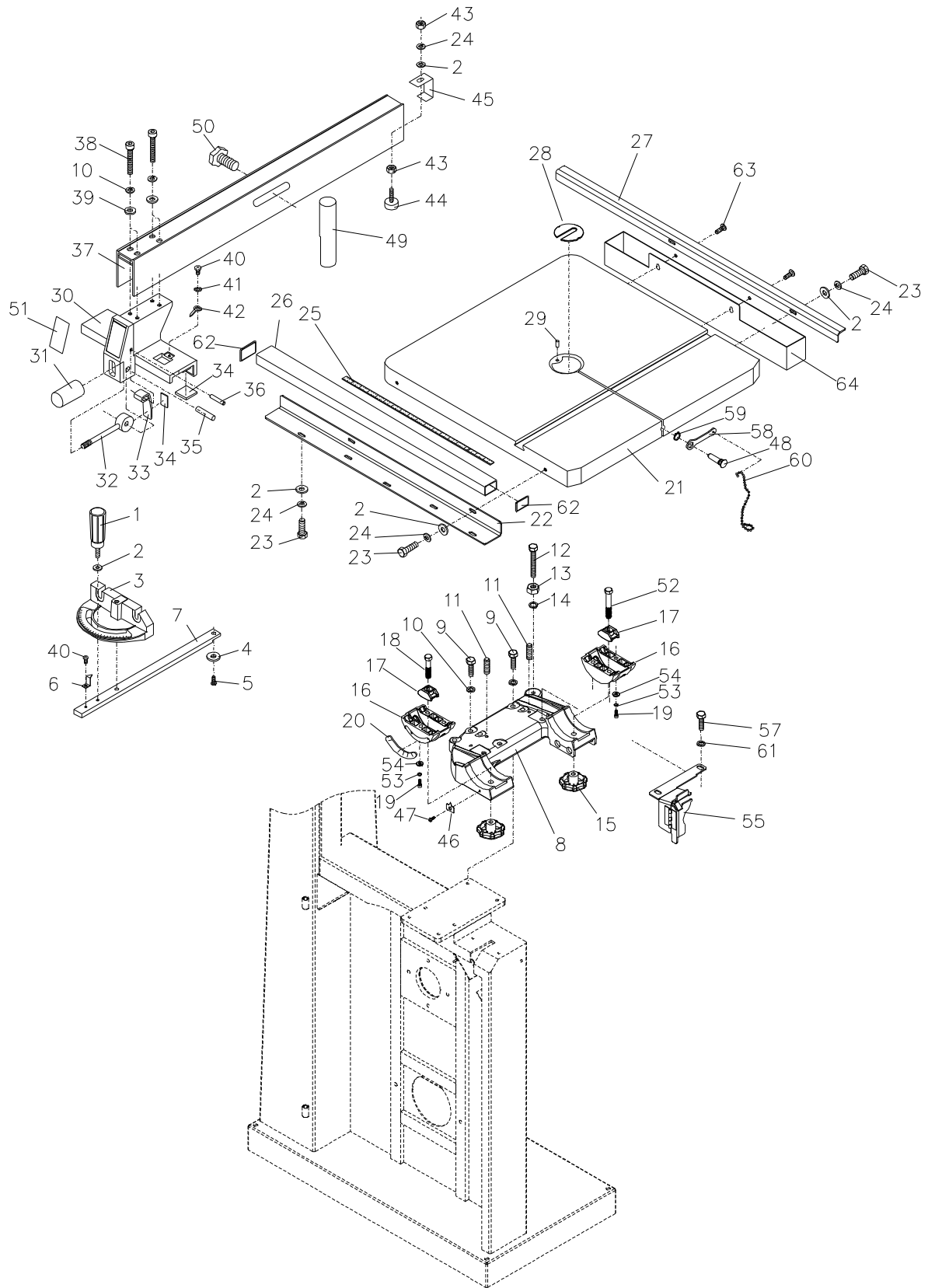

17.4.2 Parts List: Table and Fence Assembly

Index No.	Part No.	Description	Size	Qty
1	JWBS18-401	Lock Handle		1
2	TS-0680021	Flat Washer	1/4	11
3	JWBS18-403	Miter Gauge Body		1
4	JWBS20-156	Guide Disc		1
5	JWBS18-405	Screw	M6x8	1
6	JWBS18-406	Pointer		1
7	JWBS18-407	Guide Bar		1
8	JWBS18DX-408	Trunnion Support Bracket		1
9	TS-0051071	Hex Cap Screw	5/16-18x1-1/2	4
10	TS-0720081	Lock Washer	5/16	8
11	TS-0270061	Set Screw	5/16-18x5/8	2
12	TS-0060111	Hex Cap Screw	3/8-16x2-1/2	1
13	TS-0561031	Hex Nut	3/8-16	1
14	TS-0720091	Lock Washer	3/8	1
15	JWBS18-415	Lock Knob		2
16	JWBS18X-416	Trunnion		2
17	JWBS18-417	Trunnion Clamp Shoe		2
18	TS-1491081	Hex Cap Screw	M10x50	1
19	TS-1503041	Socket Head Cap Screw	M6x16	6
20	JWBS18-420	Scale		1
21	VBS18MW-421	Table		1
22	JWBS18-422G	Front Rail		1
23	TS-0050021	Hex Cap Screw	1/4-20x5/8	9
24	TS-0720071	Lock Washer	1/4	10
25	JWBS18-425	Scale		1
26	JWBS18-426G	Guide Rail		1
27	VBS18MW-427G	Rear Rail		1
28	JWBS20-144	Table Insert		1
29	JWBS20-145	Roll Pin	3x10	1
30	JWBS18-430	Fence Body		1
31	JWBS18-431	Knob		1
32	JWBS18-432	Lock Handle		1
33	JWBS18-433W	Lock Plate		1
34	JWBS18-434	Pad		5
35	JWBS18-435	Pin		1
36	JWBS18-436	Pin		1
37	JWBS18-437EA	Fence		1
38	TS-0208041	Socket Head Cap Screw	5/16-18x3/4	4
39	TS-0680031	Flat Washer	5/16	4
40	TS-0810012	Screw	#10-24x1/4	2
41	TS-0733031	External Tooth Lock Washer	#10	1
42	JWBS18-442	Pointer		1
43	TS-0561011	Hex Nut	1/4-20	2
44	JWBS18-444	Sliding Pad		1
45	JWBS18-445	Rear Hook		1
46	JWBS18-446	Pointer		1
47	JWBS18-447	Screw	M5x8	1
48	JWBS18DX-448	Table Pin		1
49	JWBS18-449E	Resaw Post		1
50	JWBS18-450	Lock Knob		1
51	JWBS18-451	JET Fence Label		1
52	TS-2210651	Hex Cap Screw	M10x65	1
53	TS-1551041	Lock Washer	M6	6
54	TS-1550041	Flat Washer	M6	6
55	JWBS18DX-455G	Lower Blade Guard		1

Index No.	Part No.	Description	Size	Qty
57	TS-0051091	Hex Cap Screw	5/16-18x2	2
58	40-0260	Wrench		1
59	JWBS18DX-459	C-Ring	S-10	1
60	JWBS18DX-460	Link Chain		1
61	TS-0680031	Flat Washer	5/16	2
62	2013-285	End Cover		2
63	TS-081F032	Pan Head Screw	1/4-20x1/2	2
64	VBS18MW-464G	Upper Chip Tray		1
	JWBS18-MGCP	Miter Gauge Assembly		1
	VBS18MW-FCPA	Fence/Rails Assembly		1

18.0 Electrical Connections

