

KPO12-23

Legend

- | | |
|--|-----------------------|
| 1 Breaker | 11 On/Off Switch |
| 2 Condenser Hot Air Exhaust (20" Dia. Flange) | 12 Temp. Up Control |
| 3 Cam Lock | 13 Temp. Down Control |
| 4 Control Panel Door | 14 Display |
| 5 Condenser Intake | 15 Temp. Set Control |
| 6 Skid Mount | 16 Skin Panel Lock |
| 7 Detachable Wheel (8" Dia) | |
| 8 Return Air (12" Dia. Flange) | |
| 9 Cold Air Supply (12" Dia. Flange) | |
| 10 Condenser Intake | |

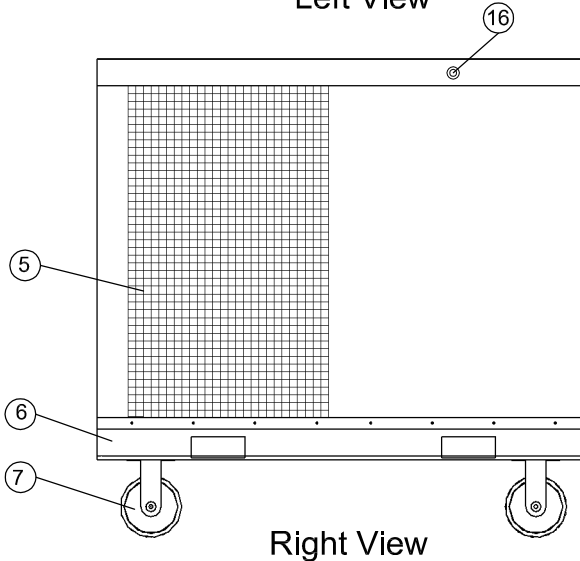
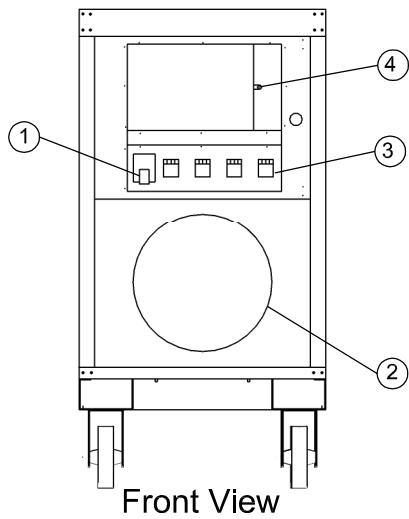
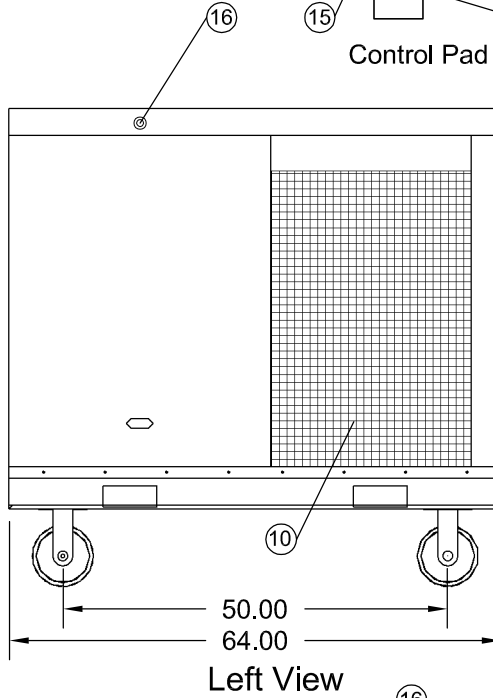
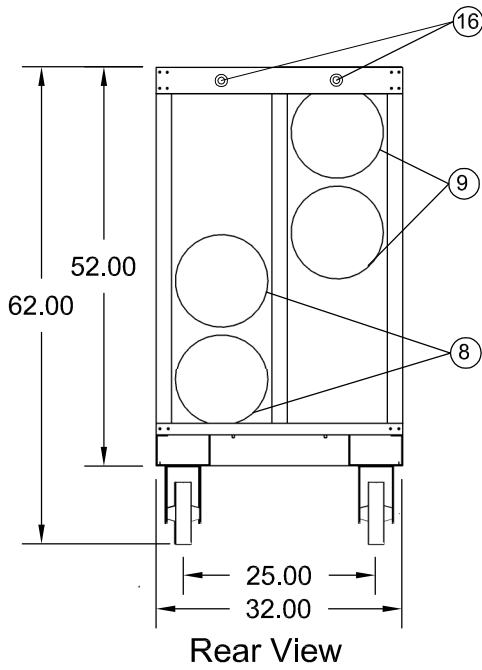
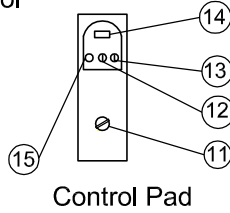

ETL LISTED CONFORMS TO ANSI/UL
1995 CERTIFIED TO CAN/CSAA22.2 NO.235



1-800-KWIKOOL

SPECIFICATIONS**Model KP012-23 - 12 Ton**

COOLING CAPACITY		
BTU/hr @ 95 F at 60%RH	135,000 (Nominal 12-TON)	
CONSTRUCTION		
Skid	12-Guage Galvanized Steel	
Cabinet	16-Guage Powder Coated Galvanized Steel	
COMPRESSOR DATA		
Compressor Type	Reciprocating	
Condenser Operating Temperatures	30-110F.	
Non-CFC Refrigerant Charge (Lbs.)	407C	
FAN DATA		
EVAPORATOR		
Fan Type (Centrifigul) - 2	Direct Drive	
Air Flow (CFM)	5000	
Supply & Return Air Flanges - 4	Two 12-inch Flanges for Each	
Maximum Duct Length	50 Feet for Supply & Return	
CONDENSER		
Fan Type (Centrifigul)	Belt Drive	
Air Flow (CFM)	6,500	
Condenser Exhaust Flange	One 20"Diameter Flange	
Condenser Maximum Duct Length	100 Feet	
ELECTRICAL DATA		
Indoor/Outdoor	Approved	
Power Supply (Volts)	208-230-volt - 3 Phase	
Current Consumption (Amps/KW)	72	
Maximum Circuit Breaker (Amps)	80	
Minimum Circuit Ampacity (Amps)	78.5	
Min/Max Voltage	195-250	
Plug Configruation	Cam Locks	
DIMENSIONAL DATA		
Width x Lenth x Height (Inches)	32 x 64 x 52 w/o 8-in Wheels	
Weight (Lbs)	1,392	
Shipping Weight	1,462	
Swivel Locking Heavy Duty Castors	8 inches	
SAFETY DEVICE DATA		
Phase Monitor	YES	
Compressor Overload	INTERNAL	
Fan Motor Overload	AUTOMATIC INTERNAL	
High Pressure Switch	MANUAL	
Low Pressure Switch	AUTOMATIC	
Compressor Short Cycle	YES	
Compressor Time Delay	YES	
Automatic Restart	YES	
Thermostat	MICROPROCESSOR/DIGITAL	



1-800-KWIKOOL