

SPECIFICATIONS

MODEL NUMBER	SRF-40/50
EXTERNAL DIMENSION (INCH)	16" X 32" X 45.9"
NUMBER OF BURNERS	3
FRYER CAPACITY	45 - 50 LBS
BTU (EACH BURNER AT 5" W.C)	38,000
TOTAL BTU	114,000
NET WEIGHT	152 LBS
SHIPPING WEIGHT	167 LBS

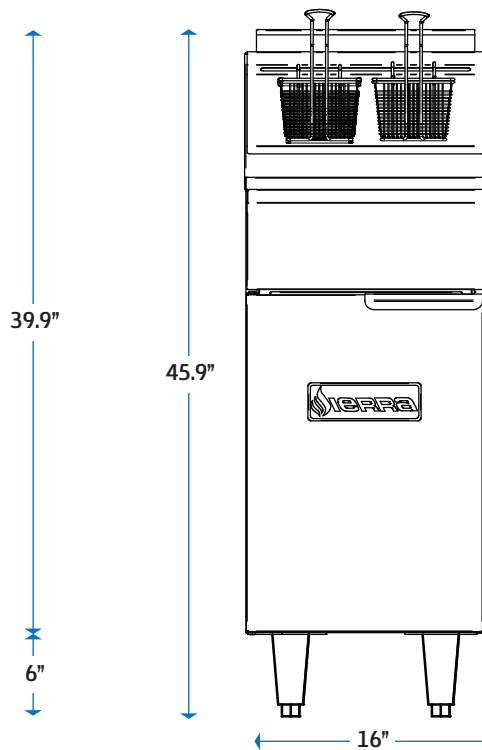
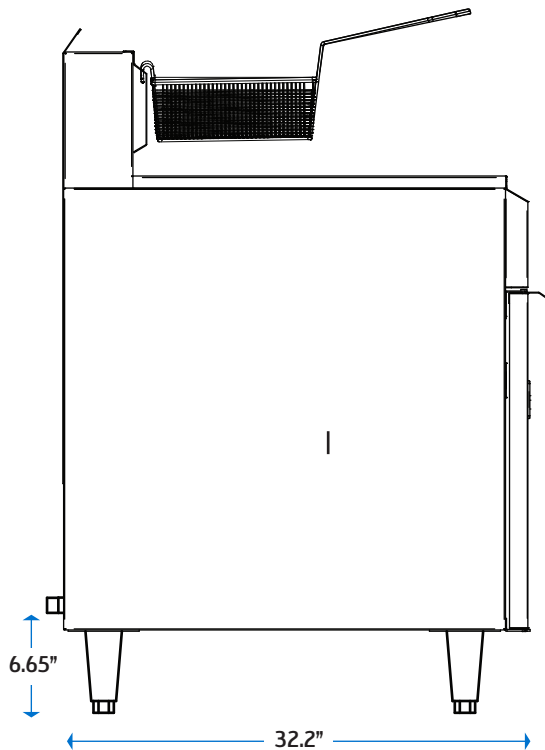

Warranty: 12 months parts & labor. Limited warranty on fryer tank. Tank is 5 years pro-rated.

Gas Connection: 3/4" NPT on the right hand rear of the appliance. The pressure regulator (supplied) is to be connected here by the installer.

Gas pressure: 5" W.C. - Natural Gas | 10" W.C. - Propane

Combustible Clearances: For use in non-combustible locations | Non-combustible Clearances: 0 inches sides, 0 inches rear
Specify type of gas and altitude, if over 2,000 feet, when ordering.



SIERRA RANGE is a registered trademark of **MVP Group**.

Due to continuing product development, to ensure best possible performance, the specifications are subject to change without prior notice.



PROJECT NAME: _____

LOCATION: _____

ITEM: _____ QTY: _____

MODEL: _____

SRF-40/50

TUBE FIRED GAS FRYER

The Sierra all-purpose fryers feature outstanding reliability and durability, capable of cooking a wide variety of fried foods with consistent uniformity and great taste.

Three, highly efficient tube fired, cast iron burners create a large heat-transfer area for reliable, even heat distribution. Our durable temperature probe senses temperature changes and activates a quick burner response.

The open fry-pot has a large heat-transfer area. Every inch of the frypot and cold zone can be cleaned and wiped down by hand.

The large cold zone and forward sloping bottom help collect and remove sediment from the frypot to safeguard oil quality and support routine frypot cleaning.

Four durable black plastic locking casters are optional.



STANDARD FEATURES

- Welded 16 gauge stainless steel tank with a super smooth machine finish ensures easy cleaning
- Stainless steel front, door and sides, with a galvanized back
- Long lasting baffles are mounted in the heat exchange tubes to provide maximum heating and combustion efficiency
- Standing pilot light design provides a ready flame when heat is required
- Integrated gas control valve acts as a manual and pilot valve, automatic pilot valve, gas filter, pressure regulator and automatic main valve
- Built-in heat deflector
- Two nickel plated oblong wire mesh baskets, with vinyl coated heat protection handles
- One nickel plated tube rack and drain extension
- 6" adjustable stainless steel legs
- The SRF-40/50 comes shipped with Natural Gas orifices pre-installed. An additional set of L.P Gas orifices are included.