

SPECIFICATIONS

MODEL NUMBER	SRSP-18
EXTERNAL DIMENSION (INCH)	18" X 25.2" X 25.25"
NUMBER OF BURNERS	1
TOTAL BTU	90,000
NET WEIGHT	110 LBS
SHIPPING WEIGHT	128 LBS

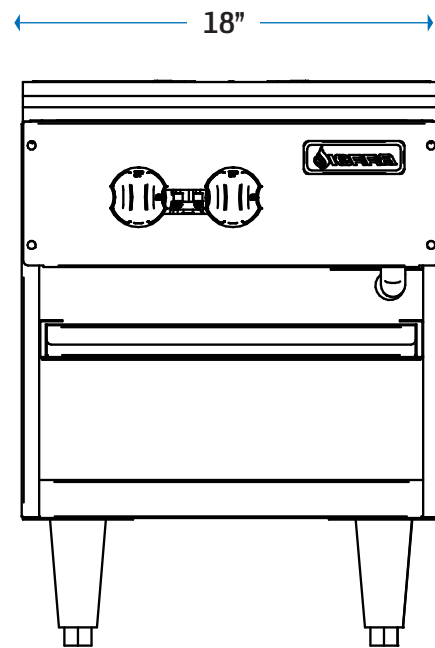
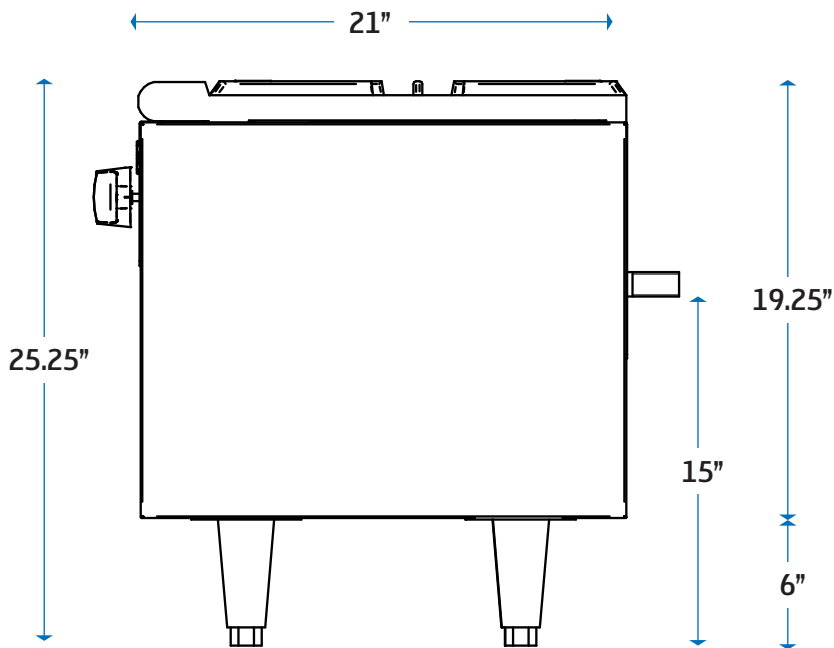

Warranty: 12 months parts & labor.

Gas Connection: 3/4" NPT on the right hand rear of the appliance. The pressure regulator (supplied) is to be connected here by the installer.

Gas pressure: 5" W.C. - Natural Gas | 10" W.C. - Propane

Combustible Clearances: For use in non-combustible locations | Non-combustible Clearances: 0 inches sides, 0 inches rear
Specify type of gas and altitude, if over 2,000 feet, when ordering.

SIERRA RANGE is a registered trademark of **MVP Group**.

Due to continuing product development, to ensure best possible performance, the specifications are subject to change without prior notice.





PROJECT NAME: _____

LOCATION: _____

ITEM: _____ QTY: _____

MODEL: _____

SRSP-18

STOCK POT RANGE

The Sierra SRSP-18 features an all-stainless steel construction, that includes heavy duty cast iron burners, each rated at 90,000 BTU/Hr, providing lightning quick heating. The dual control valves, for the inner and outer rings, allow maximum precision to maintain desired heat.

The full width drip tray catches spills, with a lower cabinet for storage. The SRSP-18 features a modern look and design, form and function fit for the most demanding kitchens at an affordable price. All with the ease of modular customization.



STANDARD FEATURES

- Stainless steel construction: interior and exterior front, sides and valve controls
- Heavy gauge welded front frame
- Heavy duty 18" x 21" cast iron top grates, easily removable for easy cleaning, industry standard size
- Lift-off top two piece, cast iron burners
- One stainless steel standing pilot for each burner for instant ignition
- Pilot shield protects pilot from spills and grease
- Full width drip tray to catch spills
- Dual control valves; one for the inner ring and one for the outer ring
- Sloping design of cast iron bowl guides any spill away from the burner's ports, protects the flame and preventing clogs
- Sturdy lower cabinet storage cavity
- 6" stainless steel legs with adjustable steel feet
- The SRSP-18 comes shipped with Natural Gas orifices pre-installed. An additional set of L.P Gas orifices are included.