

# QwikSwap™ Installation Instructions

To replace Constant Torque ECM Blower Motors with a Permanent Split Capacitor (PSC) Motor and Variable Speed Control Board

## CAUTION

To prevent death, injury, or property damage, read and follow all instructions and warnings, including labels shipped with or attached to unit.

## WARNING

Improper installation, adjustment, alteration, service maintenance, or use can cause explosion, fire, electrical shock, or other conditions that could cause personal injury or property damage. For use by qualified technicians only.

**1** Turn off power.

**2** Verify that you have a Constant Torque Blower motor such as an X13® or SelecTech® Constant Torque ECM motor.

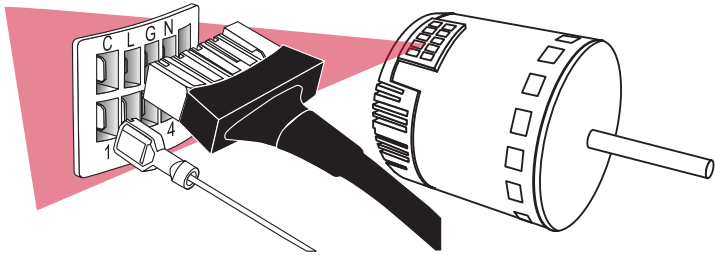

**3** Note the terminal location and corresponding color of each wire that connects to the blower motor. A reference diagram is shown below for convenience.

Disconnect these wires from the motor (if they are part of a molded plug, simply unplug it).

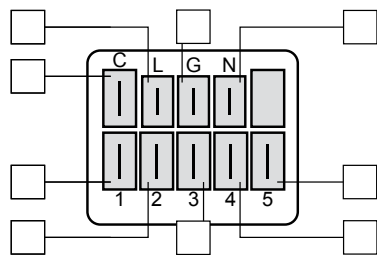

**4** Remove the old blower motor and note the shaft size, frame size (typically 48Y) operating voltage, and motor horsepower.

SHAFT SIZE:  
FRAME SIZE:  
VOLTAGE:  
HORSEPOWER:

SHAFT SIZE:	
FRAME SIZE:	
VOLTAGE:	
HORSEPOWER:	

**5** Install a new Permanent Split Capacitor (PSC) Blower motor with the specifications noted in Step 4 (ideally a 3 speed tap motor should be used). Properly ground the motor and install the capacitor in a location that protects the terminals from a short circuit or ground fault.

! If needed, a tie wrap (with mounting hole) and sheet metal screw are provided to secure the capacitor to the air handler sheet metal.

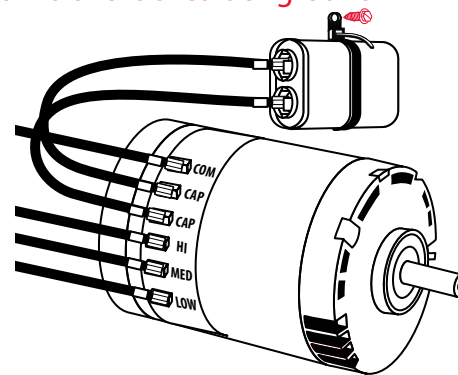

**6** Identify a good mounting location with sufficient clearance. Use the supplied self-drilling sheet metal screws to attach the mounting bracket.

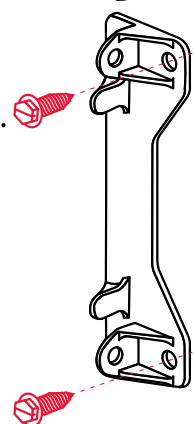

**7** Install the power and control wires that were removed from the old motor onto the matching terminals of the QwikSwap™ board. Refer to the wiring diagram created in Step 3 for proper connection locations.

! The terminals on the wires that were removed from the old motor **MUST BE FULLY INSULATED** or part of a molded plug that will plug directly into the QwikSwap™ board.

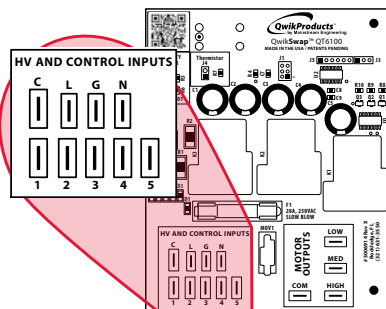

**8** Connect the PSC blower motor power leads (HIGH, MED, LOW, COM) to the corresponding output terminals (HIGH, MED, LOW, COM) on the QwikSwap™ board.

! If the PSC motor leads do not have insulated terminals, four insulated 1/4 inch female quick disconnect terminals have been provided to connect the PSC power leads to the QwikSwap™ Board.

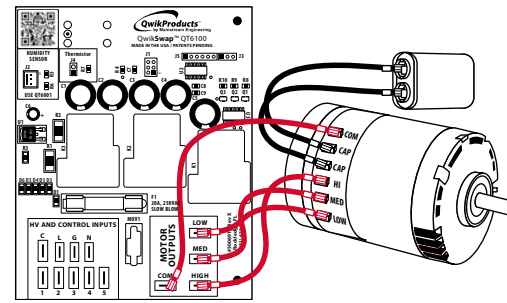

! If the new PSC blower motor has quick disconnect terminals instead of wires, you will have to fabricate the four wires (Minimum 14 gauge) with quick disconnect terminals at each end to connect the High, Medium, Low and Common connections from the QwikSwap™ to the PSC motor. Eight insulated 1/4 inch female quick disconnect terminals have been provided.

If the new blower motor has more than three speeds, use the highest, lowest and one of the mid-range speeds.

If the new blower motor only has two speed taps, jumper the low- and medium-speed quick disconnect connectors on the QwikSwap™ board together and connect them to the low speed tap on the motor.

**WARNING: Do not jumper the motor windings.**

**9** Attach the QwikSwap™ board to its mounting bracket.

! Secure the QwikSwap™ to the bracket using the supplied plastic clips. Press the clips through the bracket holes until the clips snap in place.

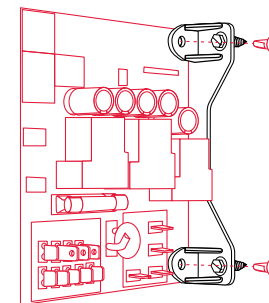

**10** Attach the thermistor to an evaporator return bend near the coil inlet.

! Route the thermistor wire to the evaporator, and using the supplied loop clamp, attach the thermistor to any return bend near the coil inlet. Secure the clamp using the supplied plastic ratchet rivet.

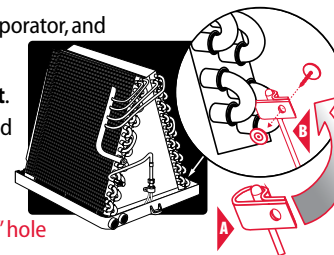

For furnace systems, route the thermistor wire outside of the ignition chamber by drilling a 5/16" hole and using the supplied grommets.

**11** When using the optional QT6001 humidity sensor, connect the sensor following the QT6001 installation instructions.

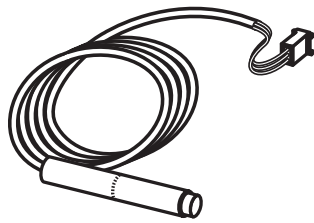

**12** Using the supplied tie wraps, bundle any excess wires to avoid interference with the blower.

**13** Reconnect power.

**! Need Help?...**

- ▶ Call 1-321-631-3550
- ▶ View an online video installation tutorial at [www.qwik.com/qwikswap/](http://www.qwik.com/qwikswap/)
- ▶ Scan this code..... with your smartphone.
- ▶ Chat online with "Live Help" at our website.



[www.qwik.com/qwikswap/](http://www.qwik.com/qwikswap/)

**QwikProducts™**  
by Mainstream Engineering  
Solutions Through Advanced Technology®  
200 Yellow Place, Rockledge, FL 32955  
321-631-3550

U.S. Patent Pending, ©2015 Mainstream Engineering Corporation  
All marks shown within this document are properties of their respective owners. X13 is a registered trademark of Regal Beloit and SelecTech is a registered trademark of Nidec Motor Corporation. QwikProducts™ and QwikSwap™ are trademarks, and Solutions Through Advanced Technology is a Registered Trademark of Mainstream Engineering Corporation.

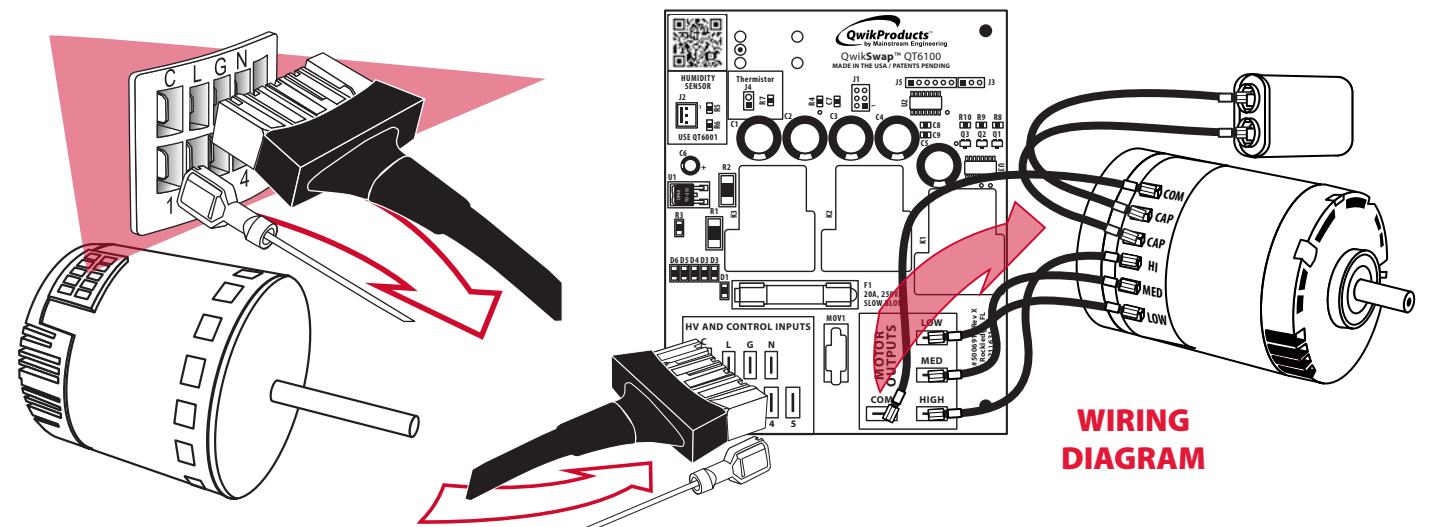

**WIRING DIAGRAM**