

7'-8'

MODEL SERIES
INSTALLATION HEIGHTS

7'-8'

LPV2

7'-8'

SANITATION, ETL,
LPN2,N2 NH2

8'-10'

STD2

8'-12'

PH

10'-12'

HV2

14'-16'

EP2

12'-16'

WMI, WMH

12'-30'

BD

The most cost-effective environmental & sanitation barrier you'll **never** see



ETL Certified to ANSI/NSF Standards,
Sleek, Quiet, Consumer-Friendly Design

ETL Sanitation 2 Series **commercial air curtains**

ETL SANITATION 2 INNOVATIONS

- ETL Certification to ANSI/NSF Standards
- New low profile durable metal design
- Low noise level for quiet operation
- Easy to install
- Low maintenance and operational costs
- Standard Color – Obsidian Black
(Special Colors – Titanium Silver/Pearl
White/Stls Steel - \$\$ adder)

FEATURES IN ALL MARS AIR CURTAINS

- Maintains consistent interior temperature
- Minimizes dirt, dust, and fumes
- Controls flying insects
- Allows for unobstructed views...enhancing safety
- Effective environmental control
- Reduced energy consumption

800.421.1266 marsair.com

mars

atmosphere is everything

7'-8'

ETL Sanitation 2 Series commercial air curtains

Model	Door Width Inches	Door Height Feet	FULL LOAD AMPS/ 1 ϕ		Sound Pressure Level (dBA)	Net Wt. LBS. Unheated
			115V	208V/ 230V		
LoPro 2 - ETL Sanitation Certified						
LPN2 25 Drive-Up	25"	5'	2.4	1.2/1.2	49	20
LPN2 36	36"	7'-8'	2.4	1.2/1.2	49	32
LPN2 42	42"	7'-8'	2.4	1.2/1.2	50	35
LPN2 48	48"	7'-8'	2.4	1.2/1.2	52	40
LPN2 60	60"	7'-8'	2.6	1.4/1.4	53	48
LPN2 72	72"	7'-8'	2.6	1.4/1.4	53	58
LPN2 84-2	84"	7'-8'	4.8	2.4/2.4	53	75
LPN2 96-2	96"	7'-8'	4.8	2.4/2.4	53	83
LPN2 108-2	108"	7'-8'	5	2.6/2.6	54	92
LPN2 120-2	120"	7'-8'	5.2	2.8/2.8	54	102
LPN2 144-2	144"	7'-8'	5.2	2.8/2.8	54	122
ETL SANITATION CERTIFIED						
N2 36	36"	7'	5.1	2.5/2.5	66	60
N2 42	42"	7'	5.1	2.5/2.5	66	65
N2 48	48"	7'	5.1	2.5/2.5	66	70
N2 72-2	72"	8'	10.2	5.0/5.0	68	145
NH2 42	42"	8'	9.0	5.0/5.0	70	125
NH 2 48	48"	8'	9.0	5.0/5.0	70	130



VALUE ADDED ACCESSORIES

- Switch
- Control Packages
- Control Panels
- Brackets
- Filters
- Colors & Finishes

All accessories have been specifically designed to enhance installation, operations, and performance.

They have been tested and are compatible to work with the appropriate Mars units to ensure that efficiency standards and performance levels are met.

For a comprehensive list of the most commonly specified accessories, please download our full accessory brochure at: marsair.com/accessories

ADDITIONAL INFORMATION

For info on how quickly our units pay for themselves in energy saving, visit:

marsair.com/ROI

For a demonstration of how air curtains work, see our CFD slides at:

marsair.com/CFD

For help selecting the right unit for your application, go to:

marsair.com/configurator

For submittal information, specifications, and manuals, download:

marsair.com/techinfo

For air curtains 101, view:

marsair.com/introvideo



800.421.1266 marsair.com

mars atmosphere is everything



atmosphere is everything

14716 S. Broadway • Gardena, CA 90248 • USA
 TEL: (310) 532-1555 • (800) 421-1266 • FAX: (310) 324-3030
 Web Site: www.marsair.com • E-mail: info@marsair.com

PROJECT		OPTIONS/ITEMS	
TITLE			
COMMENTS		DATE 4/9/15	PAGE
		REV. NO	
MODEL NO. N2 Series	DRAWING NO N2U-F	DRAWN BY TVN	CHECKED BY
		FILE NAME	

Unheated Drawing

N2 (Sanitation Customer Entrance) Series

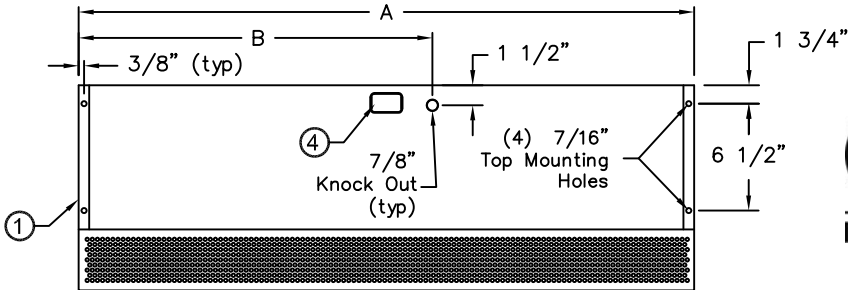
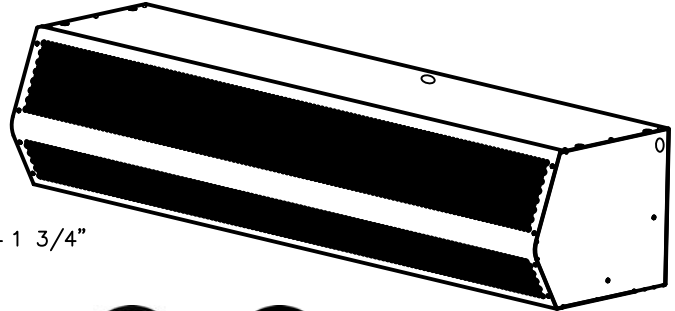

TOP VIEW



FRONT VIEW

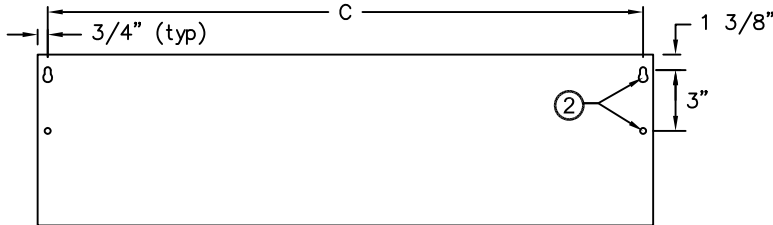

REAR VIEW



Note: Models N260-2, N264-2, N278-2, N296-3 & N2108-2 are not AMCA Certified

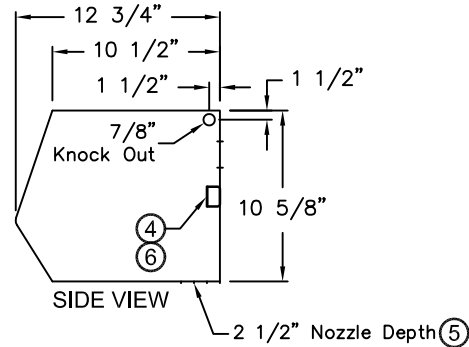

SIDE VIEW

7 Recommended Accessories

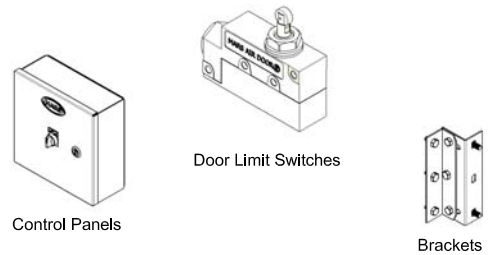

*- Use corresponding letters in "Electrical Data" columns to complete the model numbers.

MODEL NUMBER	OVERALL LENGTH A (in)	KNOCKOUT LOCATION B (in)	REAR MOUNTING CENTER C (in)
N236-1U*-OB	36	25 1/2	34 1/2
N242-1U*-OB	42	28 1/2	40 1/2
N248-1U*-OB	48	31 1/2	46 1/2
N260-2U*-OB	60	37 1/2	58 1/2
N272-2U*-OB	72	40	70 1/2
N284-2U*-OB	84	46	82 1/2
N296-2U*-OB	96	52	94 1/2
N2108-3U*-OB	108	58	106 1/2
N2120-3U*-OB	120	64	118 1/2
N2144-3U*-OB	144	76	142 1/2

Notes:

- This product is designed to meet the National Electric Code (NEC), ETL Safety Listed for the US and Canada, AMCA Certified and bear the CE mark.
- 1/2" key hole slots and 7/16" mounting holes (4) provided, (2) on each end for wall mounting.
- Cabinet has sufficient strength for fastening to wall on both ends without intermediate support.
- Internal J-Box(es) for electrical wiring: one motor-(1) 2"x 4"; two motors-(1) 4"x 4"; three motors-(2) 4"x 4".
- Unit is to be installed such that air flow is unobstructed. Air discharge nozzle containing adjustable air directional vanes with 40° sweep front to back.
- Circuit protection as per NEC by others.
- Optional motor control panel, door limit switch and mounting brackets are field installed and/or wired by others. The door limit switch is to be mounted such that the air curtain turns on as door begins to open. To prevent unit damage, the mounting brackets must be installed such that the bottom of the air curtain is not below the door header.

N2 (Sanitation Service Entrance) Series

Unheated

Model Lengths 36" – 144"



atmosphere is everything

14716 S. BROADWAY, GARDENA, CA 90248 • Ph: (310)532-1555 Fax: (310)-532-3030 • www.marsair.com
© Copyright Mars Air Systems, LLC 2014

Unheated Data Sheet

Applications: Insect Control (up to 7')

N2 (Sanitation Customer Entrance) Series 2	Mechanical Data						AMCA Certified Lab Data					
	Model Number	Nozzle Length (in)	Length (in)	Depth (in)	Height (in)	Motor (hp)	Weight (lbs)	Max Core Velocity at Nozzle (fpm)	Avg Velocity (fpm)	Volume (cfm)	Uniformity (%)	Power Rating (watts)
N236-1U*-OB	36	36	13	11	1/2	60	5960	2206	1379	84	500	
N242-1U*-OB	42	42	13	11	1/2	65	4865	1945	1418	87	510	
N248-1U*-OB	48	48	13	11	1/2	70	4247	1730	1442	85	550	
N260-2U*-OB	60	60	13	11	Two 1/2	90	6737	2592	2700	93	940	
N264-2U*-OB	64	64	13	11	Two 1/2	110	6452	2449	2721	92	957	
N272-2U*-OB	72	72	13	11	Two 1/2	120	5960	2206	2758	84	1000	
N278-2U*-OB	78	78	13	11	Two 1/2	123	5452	2064	2795	88	1015	
N284-2U*-OB	84	84	13	11	Two 1/2	125	4865	1945	2836	87	1020	
N296-2U*-OB	96	96	13	11	Two 1/2	135	4247	1730	2884	85	1100	
N296-3U*-OB	96	96	13	11	Three 1/2	165	6452	2449	4082	92	1435	
N2108-3U*-OB	108	108	13	11	Three 1/2	175	5960	2206	4137	84	1500	
N2120-3U*-OB	120	120	13	11	Three 1/2	185	4660	2084	4341	92	1570	
N2144-3U*-OB	144	144	13	11	Three 1/2	200	4247	1730	4326	85	1650	
N2144-4U*-OB	144	144	13	11	Four 1/2	235	5960	2206	5516	84	2000	

* - Use corresponding letters in "Electrical Data" columns to complete the model numbers.

Note: ETL Sanitation models available in 60 Hz only.

Features:

- ❖ 1/2 HP Continuous Duty Motors
- ❖ Sleek self-contained one piece heavy gauge corrosion proof paint lock metal design
- ❖ ETL Certified to conform to ANSI/NSF 37 Standards for Service Entrances up to 7'
- ❖ ETL Certified to conform to UL 507 (US) and CSA 22.2 (Canada) Standards
- ❖ AMCA Certified to AMCA 211 Standards
- ❖ Top and wall mounting holes provided (7/16")
- ❖ Cabinet has sufficient strength for fastening to wall on both ends without intermediate support.
- ❖ Adjustable air directional vanes with 40° sweep front to back
- ❖ Standard color is Obsidian Black
- ❖ Rust preventative electrostatic polyurethane powder coating
- ❖ 5 year parts warranty
- ❖ Freight Included (FOB Continental USA)
- ❖ Proudly Made in the USA

Options and Accessories: (see Accessories Brochure)

- ❖ Motor Control Panels
- ❖ Wall and Overhead Bracket
- ❖ Custom colors and finishes (304SS, 316SS, Aluminum)

Sound Levels: (measured at 10' in an open field)

1 Motor Unit = 66 dBA, 2 Motor Unit = 68 dBA, 3 Motor Unit = 71 dBA & 4 Motor Unit = 73 dBA

Model	Projection Velocity	
	Distance from nozzle (in)	Avg. Core Velocity (FPM)
N236-1U*-OB	36"	1522
	48"	1312
	60"	1158



MARS Air Systems, LLC certifies that the Air Curtains shown on this data sheet are licensed to bear the AMCA seal. The rating shown are based on tests and procedures performed in accordance with AMCA Publication 211 and comply with the requirements of the AMCA Certified Ratings Program.

Note: Models N260-2, N264-2, N278-2, N296-3 & N2108-2 are not AMCA Certified.

NOTE: MARS AIR SYSTEMS, LLC reserves the right to change specifications and product design without notice. Such revisions do not entitle the buyer to corresponding changes, improvements, additions or replacements for previously purchased equipment.

N2 (Sanitation Customer Entrance) Series 2	Electrical Data (FLA)			
	115v (A)	208/230v (D)	208/230v (G)	460v (H)
Model Number				
N236-1U*-OB	5.1	2.5	1.8/1.6	0.8
N242-1U*-OB	5.1	2.5	1.8/1.6	0.8
N248-1U*-OB	5.1	2.5	1.8/1.6	0.8
N260-2U*-OB	10.2	5.0	3.6/3.2	1.6
N264-2U*-OB	10.2	5.0	3.6/3.2	1.6
N272-2U*-OB	10.2	5.0	3.6/3.2	1.6
N278-2U*-OB	10.2	5.0	3.6/3.2	1.6
N284-2U*-OB	10.2	5.0	3.6/3.2	1.6
N296-2U*-OB	10.2	5.0	3.6/3.2	1.6
N296-3U*-OB	15.3	7.5	5.4/4.8	2.4
N2108-2U*-OB	10.2	5.0	3.6/3.2	1.6
N2108-3U*-OB	15.3	7.5	5.4/4.8	2.4
N2120-3U*-OB	15.3	7.5	5.4/4.8	2.4
N2144-3U*-OB	15.3	7.5	5.4/4.8	2.4
N2144-4U*-OB	20.4	10.0	7.2/6.4	3.2

* - Use corresponding letters in "Electrical Data" columns to complete the model numbers.

EXAMPLE

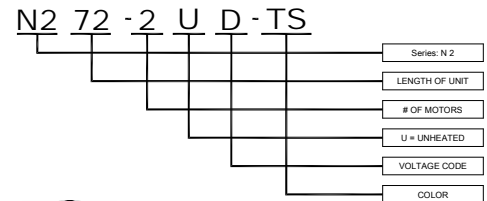

Intertek

Intertek



atmosphere is everything

14716 S. Broadway • Gardena, CA 90248 • USA
 TEL: (310) 532-1555 • (800) 421-1266 • FAX: (310) 324-3030
 Web Site: www.marsalr.com • E-mail: Info@marsalr.com

PROJECT		OPTIONS/ITEMS	
TITLE			
COMMENTS		DATE 4/9/15	PAGE
		REV. NO	
MODEL NO. NH2 Series	DRAWING NO NH2U-F	DRAWN BY TVN	CHECKED BY
		FILE NAME	

Unheated Drawing

NH2

(Sanitation Customer Entrance)
Series

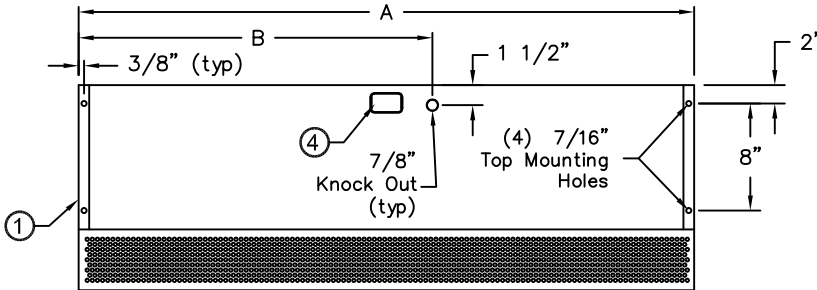

TOP VIEW



FRONT VIEW

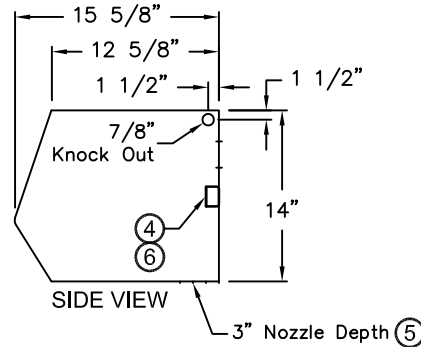

SIDE VIEW

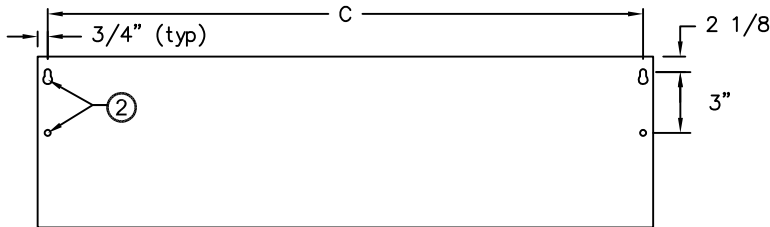

REAR VIEW



Note: Models N260-2, N264-2, N278-2, N296-3 & N2108-2 are not AMCA Certified

Recommended Accessories

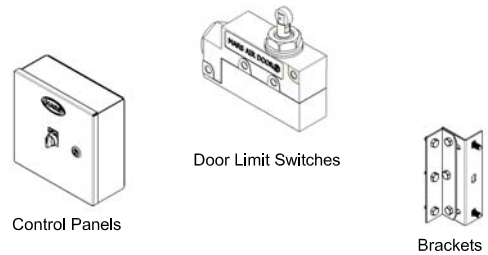

*- Use corresponding letters in "Electrical Data" columns to complete the model numbers.

MODEL NUMBER	OVERALL LENGTH A (in)	KNOCKOUT LOCATION B (in)	REAR MOUNTING CENTER C (in)
NH236-1U*-TS	36	25 1/2	34 1/2
NH242-1U*-TS	42	28 1/2	40 1/2
NH248-1U*-TS	48	31 1/2	46 1/2
NH272-2U*-TS	72	40	70 1/2
NH284-2U*-TS	84	46	82 1/2
NH296-2U*-TS	96	52	94 1/2
NH2108-3U*-TS	108	58	106 1/2
NH2120-3U*-TS	120	64	118 1/2
NH2144-3U*-TS	144	76	142 1/2

Notes:

- This product is designed to meet the National Electric Code (NEC), ETL Safety Listed for the US and Canada, AMCA Certified and bear the CE mark.
- 1/2" key hole slots and 7/16" mounting holes (4) provided, (2) on each end for wall mounting.
- Cabinet has sufficient strength for fastening to wall on both ends without intermediate support.
- Internal J-Box(es) for electrical wiring: one motor-(1) 2"x 4"; two motors-(1) 4"x 4"; three motors-(2) 4"x 4".
- Unit is to be installed such that air flow is unobstructed. Air discharge nozzle containing adjustable air directional vanes with 40° sweep front to back.
- Circuit protection as per NEC by others.
- Optional motor control panel, door limit switch and mounting brackets are field installed and/or wired by others. The door limit switch is to be mounted such that the air curtain turns on as door begins to open. To prevent unit damage, the mounting brackets must be installed such that the bottom of the air curtain is not below the door header.

NH2 (Sanitation Service Entrance) Series



Unheated

Model Lengths 36" – 144"

atmosphere is everything

14716 S. BROADWAY, GARDENA, CA 90248 • Ph: (310)532-1555 Fax: (310)-532-3030 • www.marsair.com
© Copyright Mars Air Systems, LLC 2014

Unheated Data Sheet

Applications: Insect Control (up to 7')

NH2 (Sanitation Service Entrance) Series 2	Mechanical Data						AMCA Certified Lab Data				
	Model Number	Nozzle Length (in)	Length (in)	Depth (in)	Height (in)	Motor (hp)	Weight (lbs)	Max Core Velocity at Nozzle (fpm)	Avg Velocity (fpm)	Volume (cfm)	Uniformity (%)
NH236-1U*-TS	36	36	16	14	1	115	5722	2389	1792	92	965
NH242-1U*-TS	42	42	16	14	1	120	6051	2654	2322	93	1305
NH248-1U*-TS	48	48	16	14	1	125	6144	2447	2447	88	1360
NH272-2U*-TS	72	72	16	14	Two 1	220	5722	2389	3584	92	1930
NH284-2U*-TS	84	84	16	14	Two 1	235	6051	2654	4644	93	2610
NH296-2U*-TS	96	96	16	14	Two 1	250	6144	2447	4894	88	2720
NH296-3U*-TS	96	108	16	14	Three 1	320	5896	2526	5052	93	2800
NH2108-3U*-TS	108	108	16	14	Three 1	330	5722	2389	5376	92	2895
NH2120-3U*-TS	120	120	16	14	Three 1	345	6060	2678	6693	93	3615
NH2144-3U*-TS	144	144	16	14	Three 1	375	6144	2447	7341	88	4080
NH2144-4U*-TS	144	144	16	14	Four 1	440	5722	2389	7168	92	3860

* - Use corresponding letters in "Electrical Data" columns to complete the model numbers.

Note: ETL Sanitation models available in 60 Hz only.

Features:

- ❖ 1 HP Continuous Duty Motors
- ❖ Sleek self-contained one piece heavy gauge corrosion proof paint lock metal design
- ❖ ETL Certified to conform to ANSI/NSF 37 Standards for Service Entrances up to 7'
- ❖ ETL Certified to conform to UL 507 (US) and CSA 22.2 (Canada) Standards
- ❖ AMCA Certified to AMCA 211 Standards
- ❖ Top and wall mounting holes provided (7/16")
- ❖ Cabinet has sufficient strength for fastening to wall on both ends without intermediate support.
- ❖ Adjustable air directional vanes with 40° sweep front to back
- ❖ Standard color is Titanium Silver
- ❖ Rust preventative electrostatic polyurethane powder coating
- ❖ 5 year parts warranty
- ❖ Freight Included (FOB Continental USA)
- ❖ Proudly Made in the USA

Electrical Data (FLA)	Unit Voltage (Voltage Code)				
	115v (A)	208/230v (D)	208/230v (G)	460v (H)	575v (I)
NH236-1U*-TS	9.0	5.0	3.3/3.2	1.6	1.3
NH242-1U*-TS	9.0	5.0	3.3/3.2	1.6	1.3
NH248-1U*-TS	9.0	5.0	3.3/3.2	1.6	1.3
NH272-2U*-TS	18.0	10.0	6.6/6.4	3.2	2.6
NH284-2U*-TS	18.0	10.0	6.6/6.4	3.2	2.6
NH296-2U*-TS	18.0	10.0	6.6/6.4	3.2	2.6
NH296-3U*-TS	27.0	15.0	9.9/9.6	4.8	3.9
NH2108-3U*-TS	27.0	15.0	9.9/9.6	4.8	3.9
NH2120-3U*-TS	27.0	15.0	9.9/9.6	4.8	3.9
NH2144-3U*-TS	27.0	15.0	9.9/9.6	4.8	3.9
NH2144-4U*-TS	36.0	20.0	13.2/12.8	6.4	5.2

* - Use corresponding letters in "Electrical Data" columns to complete the model numbers.
Note: For Ampacity Multiply FLA X 1.25

Options and Accessories: (see Accessories Brochure)

- ❖ Motor Control Panels
- ❖ Wall and Overhead Bracket
- ❖ Custom colors and finishes (304SS, 316SS, Aluminum)

Sound Levels: (measured at 10' in an open field)

1 Motor Unit = 70 dBA, 2 Motor Unit = 73 dBA, 3 & 4 Motor Unit = 75 dBA

Model	Projection Velocity	
	Distance from nozzle (in)	Avg. Core Velocity (FPM)
NH242-1U*-TS	36"	1833
	78"	958
	120"	732



MARS Air Systems, LLC certifies that the Air Curtains shown on this data sheet are licensed to bear the AMCA seal. The rating shown are based on tests and procedures performed in accordance with AMCA Publication 211 and comply with the requirements of the AMCA Certified Ratings Program.

Note: Models NH260, NH296-3, NH2108-2 & NH2120-2 are not AMCA Certified.

EXAMPLE

NH2 72 -2 U D -TS

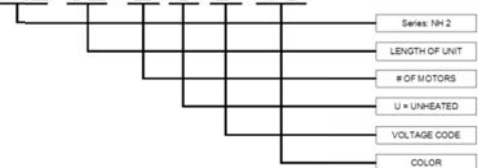

NOTE: MARS AIR SYSTEMS, LLC reserves the right to change specifications and product design without notice. Such revisions do not entitle the buyer to corresponding changes, improvements, additions or replacements for previously purchased equipment.



atmosphere is everything

Document No: IND2-IOM
Date: 0515

STANDARD 2 (STD2), HIGH VELOCITY 2 (HV2), EXTRA POWER 2 (EP2) AND ETL SANITATION CERTIFIED INDUSTRIAL SERIES

Installation, Operation and Maintenance Manual

Please read and save these instructions. Read carefully before attempting to assemble, install, operate or maintain the product described. Protect yourself and others by observing all safety information. Failure to comply with these instructions could result in personal injury and/or property damage. Retain these instructions for future reference.

OVERVIEW

Mars Air Curtains are designed to cover door openings, providing both temperature control/environmental separation and flying insect control, when the building's doors are opened. Typical installation heights are: Standard 2 Series (Environmental up to 10', Flying Insect Control up to 8'), High Velocity 2 Series (Environmental up to 12', Flying Insect Control up to 10'), and Extra Power 2 Series (Environmental up to 16', Flying Insect Control up to 14'). All ETL Sanitation Certified Series should be mounted at the Flying Insect Control heights referenced above. The units are typically wall mounted horizontally above the door opening. They can also be suspended from the ceiling or vertically mounted along side the opening. The units are ETL Listed for either an inside or outside mount. Heated units must be mounted on the inside or the protected side of the opening. The motors used in the Standard 2, High Velocity 2 and Extra Power 2 Series are 1/2HP, 1HP and 3HP respectively. The ETL Sanitation Series utilizes 1/2HP and 1HP motors.

The Standard 2, High Velocity 2 and Extra Power 2 Series come standard with an air intake grille. They can also be configured with an aluminum mesh air intake filter instead of the air intake grille or in conjunction with it.

GENERAL SAFETY INFORMATION

Use this product only in the manner intended by the

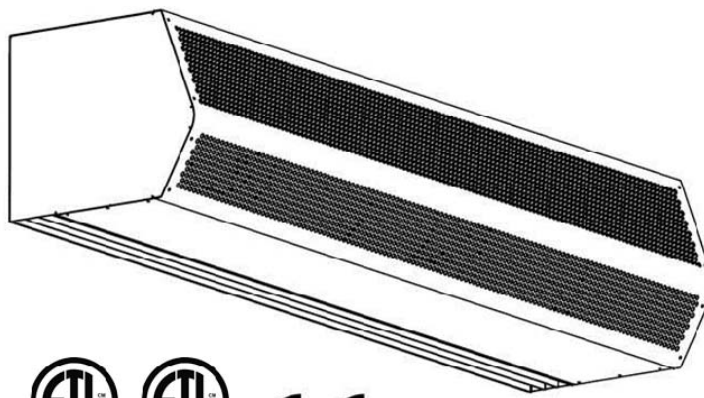

Intertek Intertek

manufacturer. If you have any questions, contact the manufacturer. Only qualified personnel should install this product. Installing personnel should have a clear understanding of these instructions and should be aware of general safety precautions. Improper installation can result in electric shock, possible injury due to coming in

contact with moving parts, as well as other potential hazards.



WARNING

To reduce the risk of fire, electric shock or injury to persons, observe the following.

- A. Always disconnect, lock and tag power source before installing or servicing product.
- B. Installation work or electrical wiring must be done by qualified person(s) in accordance with all applicable codes and standards, including fire-rated construction.
- C. The combustion airflow needed for safe operation of fuel burning equipment in the area may be affected by the product's operation. Follow the heating equipment manufacturer's guideline and safety standards, such as those published by the National Fire Protection Agency (NFPA), the American Society of Heating, Refrigeration and Air Conditioning Engineers (ASHRAE) and local code authorities.
- D. When cutting or drilling into a wall or ceiling, be careful not to damage electrical wiring and other hidden utilities.



WARNING

Precaution should be taken in explosive atmospheres.



WARNING

When servicing the product, motor may be hot enough to cause pain or injury. Allow motor to cool before servicing.

RECEIVING AND INSPECTION

Upon receiving the product, check to make sure all items are accounted for by referencing the Bill of Lading to ensure all items were received. Inspect each carton for shipping damage before accepting delivery. Notify the freight carrier if any damage is noticed. The carrier will make notification on the delivery receipt acknowledging any damage to the product. All damage should be noted on all copies of the Bill of Lading which is countersigned by the delivering carrier. A Carrier Inspection Report should be filled out by the carrier upon arrival and a report given to the Traffic Department. If damaged upon arrival, file a claim immediately with the carrier. Any physical damage to the unit after acceptance is not the responsibility of Mars Air Systems.

UNPACKING

Verify that all parts, components and accessories, and the correct quantities of each have been received. If any items are missing, report shortages to Mars Air Systems directly to arrange for obtaining the missing items. Again, verify quantities received against those on the Bill of Lading only, as multiple shipments may be involved.

INSTALLATION

Typical Mounting – Wall or Ceiling Mounted Horizontally Above the Door Opening

1. Remove the air intake grille(s) and/or filter(s) from the product and set aside. Only products 48" or less, except HV2 and EP2 models, are shipped with the motor fan assembly (MFA) mounted inside.
2. Measure the housing and center it over the opening. The air curtain shall be equal to or greater than the width of the opening.
3. Total of two (2) key-hole slots and six (6) pre-punched mounting holes are provided for your convenience. The 7/16" pre-punched holes (4) provided, (2) on each end for top/ceiling mounts. The 1/2" key-hole slot and 7/16" pre-punched hole (2) provided, (2) on each end for wall mounts. These holes must be utilized to secure the product to the wall or ceiling. If necessary, holes may be drilled inside the product to align with the stud spacing. All hardware is field provided by others.

4. Mount the product such that the discharge is 1" above the opening and all obstacles. (FIG. 1)
Note: If the product is installed higher than the recommended 1" above the opening, then it must be moved 3/8" away from the wall for every 1" that it is moved up. Any void between the wall and the product must be sealed, by others, to optimize performance.
5. Use four (4) threaded rods for overhead installation or four (4) threaded bolts for wall installation. All hardware is field provided by others. (FIG. 1)
6. If applicable, optional Adjustable Mounting Brackets, Side Extension Plates and Extended Wall Mounted Brackets are also available for installations over a Vertical Lift or Drum Roll-up type door. (Reference **Accessory Installation Supplement**)
7. If applicable, for tandem installation or products mounted side by side, allow no more than 6" between the two products. For overhead installation using threaded rods, the products may require a beam, by others, to span the full distance of the mounting length. (Reference **Accessory Installation Supplement**)
8. All wires must be connected internal of the unit and some knockouts are provided. However, it may be necessary to create your own knockout, as required.
9. The unit must be wired per NEC and local codes.

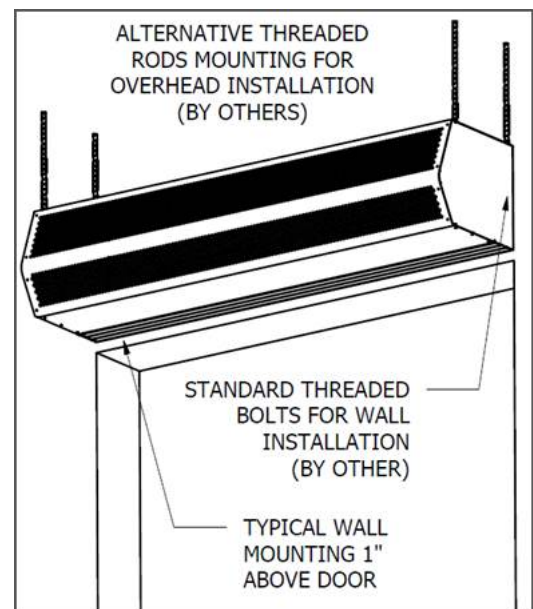

FIG. 1

Motor Fan Assembly Installation and Electrical Field Wiring

1. Once the housing is installed over the opening, the Motor Fan Assembly (MFA) must be re-placed and securely fastened. For products with the MFA shipped loose, wing nuts or hex nuts are provided inside the unit (FIG. 2). For heated MFA installation, reference **Heated Products Supplement Sheet**.
2. The unit and any optional accessories must be wired with the proper voltage to the junction box per the wiring diagram. (FIG. 3, unheated products only)

3. All 3 phase motors are bi-directional, which means they can rotate in either direction. Follow directional arrows on the blower wheel housings for proper rotation. If the motor is rotating incorrectly, switch two of the 3 phase power or motor leads and the motor will rotate the opposite direction. Make sure all motors are turning in the same and proper direction. (FIG. 2)
4. Replace the air intake grille(s) or filter(s) once the product has been properly tested.

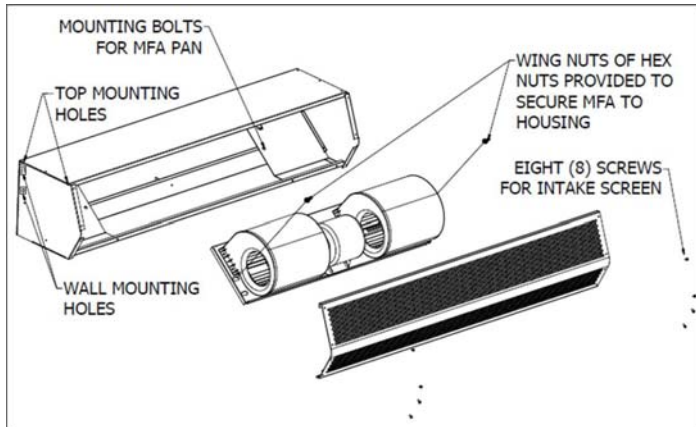

FIG. 2

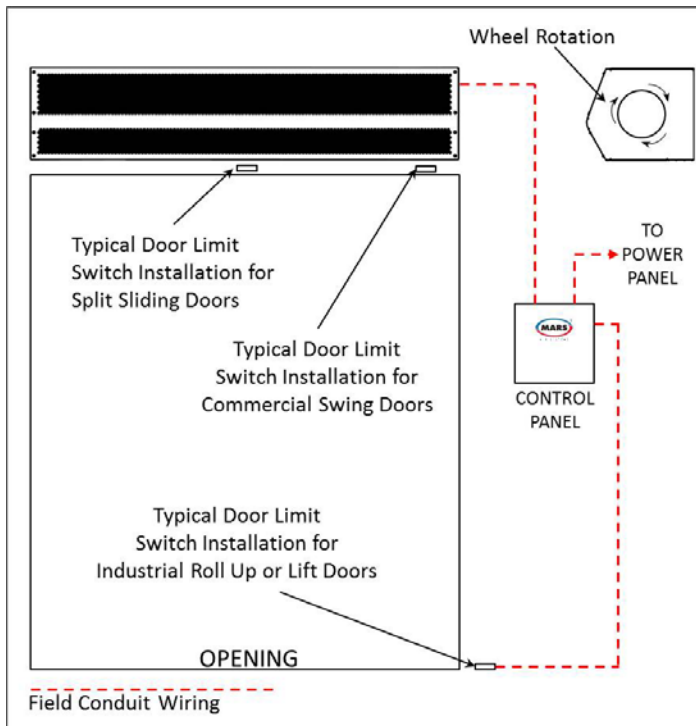

FIG. 3

NOTE

For accessory installation, reference Accessory Installation Supplement.

For heated products, reference Heated Products Supplement.

START-UP

This product has been assembled and tested at the factory prior to shipping. The following procedures should be performed to assure its performance. Before continuing with the start-up, it is important to recognize the safety controls furnished with the unit.



WARNING

The following items must all be completed by a qualified installer and checked off when completed

- A. Re-check that the product has been installed properly and is level and secure.
- B. Check all terminal screws are tight and field wiring is connected in accordance to National Electrical Code and wired per the enclosed wiring diagram. For electric heated models, ensure that the coils are secured and not touching each other on any metal surface.
- C. Verify proper voltage prior to powering the product. (See product label for reference).
- D. Check all field wired components "if supplied" are wired correctly.
- E. Check that the inlet air supply and the discharge air supply are free of obstructions.
- F. Check that all air filter(s) and/or air intake grille(s) are in place and installed properly, as originally shipped.
- G. Verify voltage to the product once more and turn power on.
- H. Regardless of whether the product is mounted on the inside or outside of the door opening, set the air directional vanes in the discharge nozzle slightly outward to approximately 10-15° towards the outside, or the wind load. (FIG. 4)

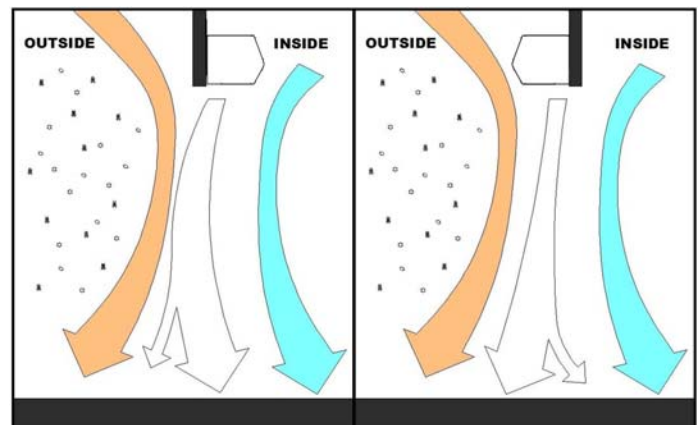

FIG. 4

- I. For products with control panels, turn the HOA (Hand-On-Auto) selector switch to "On" position and open the door to energize the product. For products without

a control panel or an On/Off switch, open the door to energize the product.

- J. If heated products are installed, reference **Heated Products Supplement**.
- K. For three phase units, verify direction of rotation of blower wheels (note direction arrows on the blower wheel housing). Correct if needed by changing polarity of three phase power.
- L. **VERY IMPORTANT** Using a clamp meter, measure the amperage to each motor and ensure that they do not exceed the amperage listed on the product label.
- M. If applicable, adjust the air intake grille(s) such that the output air stream reaches the floor. For temperature control and environmental separation applications, the air stream should reach the floor with sufficient strength to create an air seal around the door opening without creating turbulent mixing of the inside and outside air. For flying insect control applications, the air stream should reach the floor with maximum strength. If after proper installation and adjustment, the product appears to be producing too little or too much air for the application, contact the manufacturer.



WARNING

Prevent hazard of electrical shock. More than one disconnect switch may be required to de-energize this product.

MAINTENANCE



WARNING

To reduce the risk of fire, electrical shock or injury to persons, observe the following:

- A. Maintenance is to be performed only by qualified personnel who are familiar with local codes and regulations and are experienced with this type of product.
- B. Before servicing or cleaning the product switch power off at service panel and lock service panel to prevent power from being switched "ON" accidentally.

Routine maintenance is required to keep this product operating at its peak performance and efficiency. Over time, the housing, air intake grille, air intake filter, blower wheels and motor(s) will accumulate a build up of dust, debris and other residue. It is imperative to keep these components clean. Failure to do so will not only lower operational efficiency and performance, but also reduce the useful life of the product. The time between cleanings depends on the application, location and daily hours of use. On average, under normal use conditions, the product should require a thorough cleaning once every six (6) months.

To clean the product, perform the following:

1. Verify the product has been disconnected from the power source.
2. Use a damp cloth and either a warm mild soapy water solution or bio-degradable degreaser, to wipe down the exterior components of the housing.
3. To access the interior of the product, remove the air intake grille and/or air intake filter. This is accomplished by removing the eight (8) self-tapping screws on the face of each air intake grille/filter.
4. Thoroughly clean the air intake grille/filter.
5. Remove the motor fan assembly (MFA) from inside the air curtain housing. This is accomplished by loosening the watertight fitting and pulling the cord out (3 phase power) or by the quick disconnect plug on the motor (1 phase power). Then remove the two (2) wing nuts on the out board sides of the MFA pan. Care should be taken to avoid the MFA from tipping over.
6. Remove the MFA from the unit and thoroughly wipe down the motor, blower wheels and blower wheel housings. Be careful not to submerge the motor in water or spray it with a water hose.
7. The motor(s) require no additional lubrication. They are permanently lubricated and feature double sealed ball bearings.
8. To re-install the product, reverse the procedures above.
9. Reconnect the power source to the product
10. If you have any questions regarding the maintenance of the product, contact the manufacturer.

CAUTION

The appliance is not to be used by persons (including children) with reduced physical, sensory or mental capabilities, or lack of experience and knowledge, unless they have been given supervision or instruction. Children are not to play with the appliance.

DISCLAIMER

Mars reserves the right to change specifications and product design without notice. Such revisions do not entitle the buyer to corresponding changes, improvements, additions or replacements for previously purchased equipment.

TROUBLESHOOTING

PROBLEM	CAUSE	SOLUTION
NO AIR BLOWING OUT OF DISCHARGE NOZZLE	<ul style="list-style-type: none"> - No power being supplied to the unit from the electrical power source - Circuit breaker is tripped - Blown fuses on power supply - Motor overload is open or tripped - Motor contactor / relay defective (if applicable) - Failed switch 	<ul style="list-style-type: none"> - Confirm power source / check if in on position - Reset circuit breaker - Replace fuses - Allow the motor to cool down; motor has auto reset internal overload; if unit is panel equipped, press reset button on overload inside panel, or replace motor overload if overload remains tripped - Check voltage to coil; check contacts to see if they are pulling in - Replace or repair limit switch
MOTOR IS RUNNING BUT FANS ARE NOT SPINNING	<ul style="list-style-type: none"> - Loose or broken coupling (belt drive) - Loose set screws on wheel hubs - Fan spinning inside fan housing - Broken fan hub 	<ul style="list-style-type: none"> - Replace or tighten coupling - Tighten set screws on motor shaft flats - Tighten fan on shaft or replace fan - Replace fan wheels
ELECTRICAL CONTROLS NOT WORKING WHEN DOOR IS OPEN	<ul style="list-style-type: none"> - Switch is in off position - Door limit switch is not operating 	<ul style="list-style-type: none"> - Turn unit's switch to the on position - Repair or replace door limit switch
UNIT WILL NOT TURN OFF	<ul style="list-style-type: none"> - Door limit switch is permanently closed or energized 	<ul style="list-style-type: none"> - Position the door switch in a manner that turns off the unit when the door closes, and turns on the unit when the door opens. Only light pressure required.
LOW AIR FLOW	<ul style="list-style-type: none"> - Discharge air vanes out of adjustment - Obstruction on intake or discharge - Power leads out of polarity - Blower motor rotating below normal speed - Fan rubbing against housing - Blower wheels clogged with dirt 	<ul style="list-style-type: none"> - Adjust vanes to proper position (Refer to Start-Up Section in this manual) - Remove obstruction or move air curtain - Switch power leads to correct polarity (3 phase models only) - Apply proper voltage per unit requirement (see unit label) / Adjust adjustable motor speed knob (if applicable) - Free fan from housing - Clean and remove dirt from blower wheels
EXCESSIVE AIR VELOCITY AT DOOR OPENING	<ul style="list-style-type: none"> - Nozzle out of adjustment and not angled far out enough (BD only) - Air temperature too cold - Air stream pushing air outside of the building 	<ul style="list-style-type: none"> - Adjust nozzle angle to outside - Add auxiliary heat to overcome wind chill - Adjust discharge angle back into building
AIR NOT HITTING THE FLOOR	<ul style="list-style-type: none"> - Low air velocity - Obstruction in the direction of air flow - Negative building pressure 	<ul style="list-style-type: none"> - Adjust vanes to proper position or check installation height (Refer to Start-Up Section in this manual) - Remove obstruction or move air curtain (Move out 3/8" for every 1" up from the door) - Provide a make-up air system to relieve negative building pressure
UNEVEN AIR	<ul style="list-style-type: none"> - Shaft rotating inside fan - One motor not functioning 	<ul style="list-style-type: none"> - Replace fan or tighten fan on shaft - Replace or repair motor
EXCESSIVE NOISE AND OR VIBRATION	<ul style="list-style-type: none"> - Loose or broken coupling (belt drive) - Loose set screws on wheel hubs - Fan spinning inside fan housing - Broken fan hub - Bearing end caps worn - Damaged blower wheel - Bearing end caps worn - Balancing clips missing 	<ul style="list-style-type: none"> - Replace or tighten coupling - Tighten set screws on motor shaft flats - Tighten fan on shaft or replace fan - Replace fan wheels - Replace Bearing end caps - Replace Blower Wheel - Replace Bearing end caps - Replace Blower Wheel

WARRANTY

Mars' warranty coverage, period, extent and limitations apply to the product only. It does not apply to labor. Mars warrants that Mars product 1) Is free from defects in materials and workmanship and 2) Conforms to Mars' published specifications. The warranty period for Mars product except heated and custom models, is a five (5) year period commencing on its date of shipment. The date on customer's invoice is the date of shipment, unless Mars or your reseller informs you and Mars otherwise. For heated and custom models, the warranty period is an eighteen (18) month period commencing the date of shipment. Mars will provide free replacement of any part that fails as a result of a defect in material or manufacturer's workmanship. Changes in operational specification parameters that are different from those provided on the original purchase order are not covered. Mars product is inspected and tested before packaging and is shipped in working condition. The warranty for Mars product only covers free-of-charge replacement of failed parts. The warranty does not cover labor and transportation expenses that may be required to provide and to install replacement parts. Because in many instances, it is impossible to determine the cause of failure, customer may be responsible for transportation charges associated with replacement of failed part. Mars does not warrant uninterrupted or error-free operation of Mars product. Under no circumstance is Mars liable for any of the following: 1) Third-party claims against you for damages; or 2) Special, incidental, or indirect damages or for any economic consequential damages (including lost profits and savings), even if Mars, its suppliers, or its reseller is informed of their possibility. The warranty does not cover repair or exchange of Mars product resulting from misuse, accident, modification, unsuitable physical or operating environment, improper maintenance and installation by customer, or failure caused by a product for which Mars is not responsible. The warranty does not cover damages caused by mishandling during transportation. The warranty is voided by removal or alteration of Mars product or parts identification labels, by improper installation of product, and resulting non-compliance to federal, state and local codes and regulations. Additionally, Mars reserves the right to void the warranty for non-payment of invoice.

CONTACT FACTORY FOR COMPLETE PARTS LIST FOR ALL MODELS.

KEEP THIS MANUAL FOR YOUR RECORDS.

Model Number: _____

Serial Number: _____

Date Purchased: _____

Dealer Purchased From: _____



atmosphere is everything

14716 S. Broadway St., Gardena, CA 90248

(310) 532-1555 • (800) 421-1266

Fax: (310) 324-3030

Please go to our website at www.marsair.com for a downloadable version of this document.

HEATED PRODUCTS SUPPLEMENT

NOTE

Before proceeding, refer to the units specific IOM Manual for safety, installation and start information. Verify proper voltage to the product per local and NEC codes. Ensure proper rotation for units with three phase motors.

Electrically Heated Products

Electrically heated products must be mounted on the inside of the building. Electrically heated products come standard with a thermostat (provided and shipped loose, unless ordered as factory pre-mounted) and is to be field installed.

Note:

1. Electrically heated Low Profile and Phantom units come with internally mounted controls and are available with an optional 24 volt or 240 volt thermostat.
2. Electrically heated Standard, High Velocity and Extra Power units include a motor control panel mounted on the right-hand side of the unit, as standard, and a remote 24 volt thermostat with On/Off switch with terminals provided.
3. Electrically heated Wind Stopping and WindGuard units include an electric heater control panel mounted on the right hand side, as standard (FIG. 1). Optional motor/unit control panel available, which includes a remote 24 volt thermostat with On/Off switch with terminals provided.

The thermostat should be mounted as close to the product's discharge air flow as possible in order to best sense the discharged air temperature around the door opening. Connect proper voltage to the product per local and NEC codes. (FIG. 2)

Thermal overload protection is built into the heater coil assembly/assemblies. In the event of an overload condition, electrical power will be disconnected from the heater coil. Upon diagnosing the problem, electrical power can be re-instated to the heater coil(s) by manually resetting the thermal overload lever(s) or buttons(s) located in the unit or panel.

To operate multiple units mounted side by side, utilizing a single door switch and single thermostat, a master/slave configuration is required. (FIG. 2)

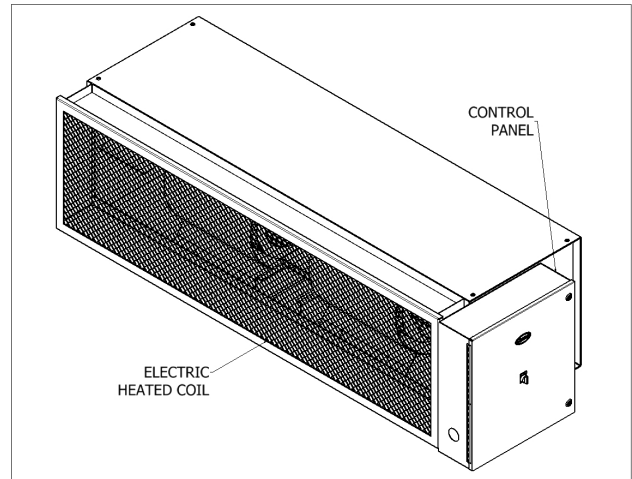

FIG. 1 (Electrically Heated WMI unit)

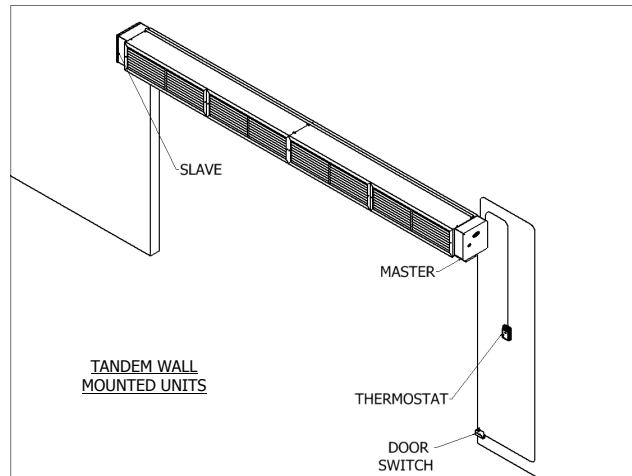

FIG. 2 (Tandem Mounted Master/Slave Units)

Steam and Hot Water Coil Heated Products

Steam/Hot Water Coil (coil) heated products must be mounted on the inside of the building. The coil(s) for Low Profile and Phantom units are shipped internally mounted to the unit. For Standard, High Velocity and Extra Power units, the coil(s) are shipped loose and field installed. Wind

Stopping and WindGuard units are shipped with coil(s) factory mounted.

Once the coil has been secured to the cabinet, access to the motor and fan is through the removable access panels located on the top of the cabinet.

Note: Low Profile and Wind Stopping units require the removal of the coil to access the motor and/or fans.

All piping should be done by a licensed pipe fitter and in accordance with local codes and regulations. Connect the supply and return fittings as required. All traps and valves are sized and field installed by others. Standard coil configuration is right hand supply and left hand return. (FIGS. 3 & 4) Optional temperature controls, if ordered, are to be field installed by others.

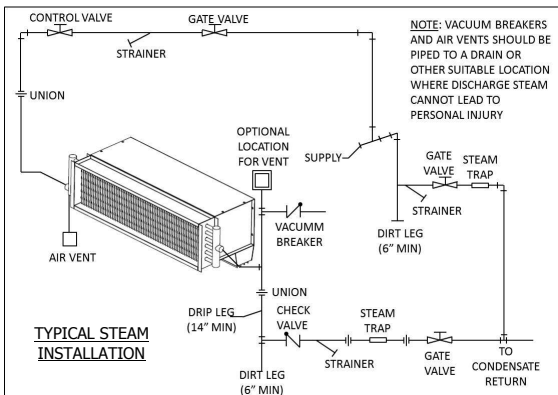

FIG. 3 (Steam Heated STD Unit)

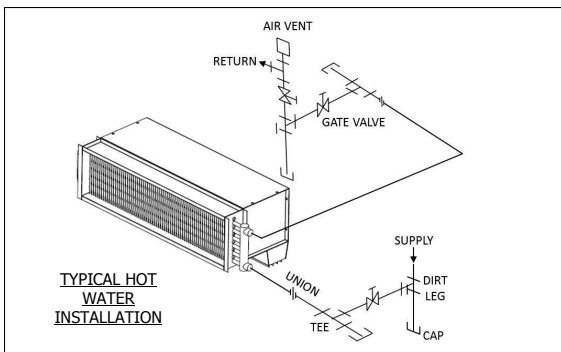

FIG. 4 (Hot Water Heated STD Unit)

Gas Heated Products

Gas heated products must be mounted on the inside of the building. The product consists of three major components: the air curtain, transition section(s) and indirect gas fired duct furnaces(s) (FIG 5).

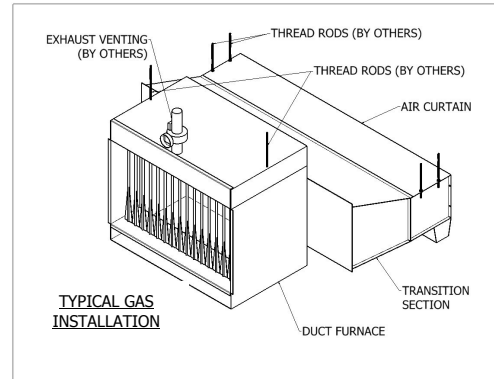

FIG. 5 (Indirect Fired Gas Heated HV

AC Unit) installed per their supplemental instructions. (FIG. 6)

Note:

1. Assemble the transition section(s).
2. Measure the width of the transition section(s) to determine the installation location for the duct furnace(s).
3. The duct furnace(s) are typically hung from above, with threaded rods, in order to support the weight of the duct furnaces. The duct furnace(s) must be centered and fastened to the transition(s) with the hardware provided.
4. Move the adjustable filler plates to close gaps in the transition(s) and secure the flanges to the transitions.

All gas piping and duct furnace(s) exhaust venting should be done by a licensed pipe fitter and in accordance with local codes and regulations. Power vented exhaust duct runs should not exceed 100' for horizontal venting.

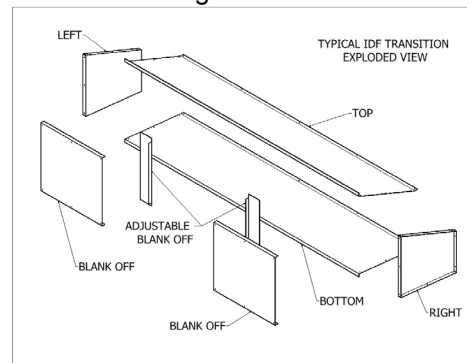

In the United States, Installation must conform with local codes or, in the absence of local codes,

with Installation of the National Fuel Gas Code, ANSI Z223.1-latest edition, from the American National Standard Institute. Further reference should be made to the recommendation of your fuel supplier. In Canada, Installation must conform with local codes or, in the absence of local codes, with Installation Codes for Gas Burning Appliances and Equipment, CGA Standard CAN/CGA 1B-149. Further reference should be made to the recommendation of your fuel supplier.

ACCESSORY INSTALLATION SUPPLEMENT

Door Limit and Magnetic Reed Switches

1. Mars door limit and magnetic reed switches are available with NEMA 1, 4X and 7 ratings. Contact the factory for additional ratings and details. (See FIG. 1 for typical single swing, hinged door type, door limit switch installation)

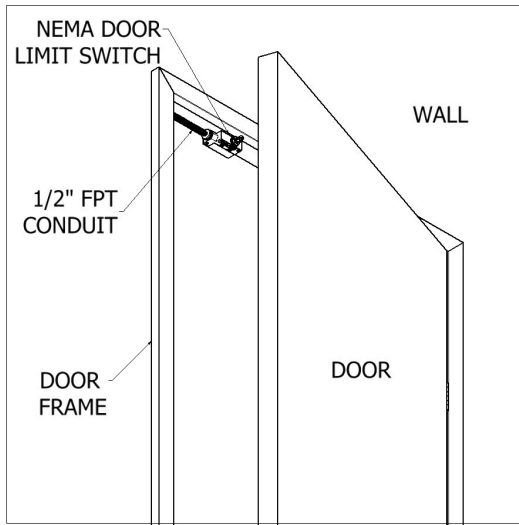

FIG. 1

2. Use light gauge materials when field fabricating brackets to activate and deactivate the door limit switch(s). (FIG. 2) Figure 2 also shows the typical installation of the combination plunger/roller type NEMA 1 door limit switch, for all non-hinged style doors.

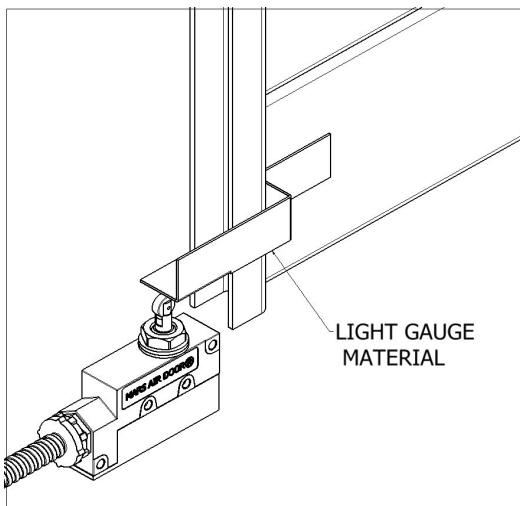

FIG. 2

3. All wiring must be per local and NEC (National Electric Code) codes.
4. Panels or controllers may be required. Refer to wiring diagram inside the control panel box.

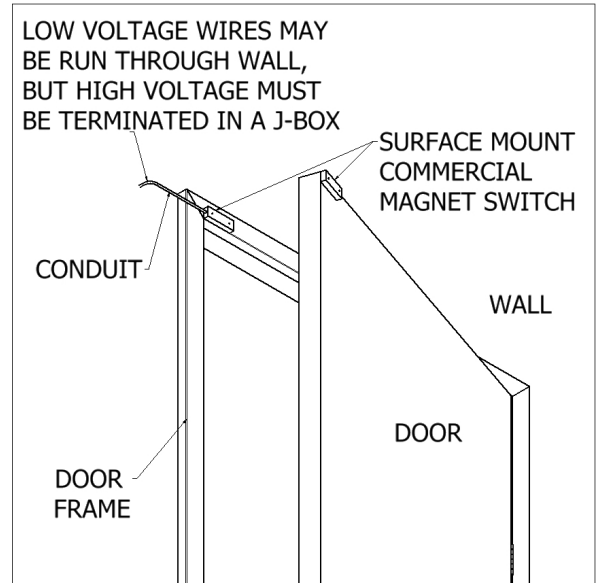

FIG. 3

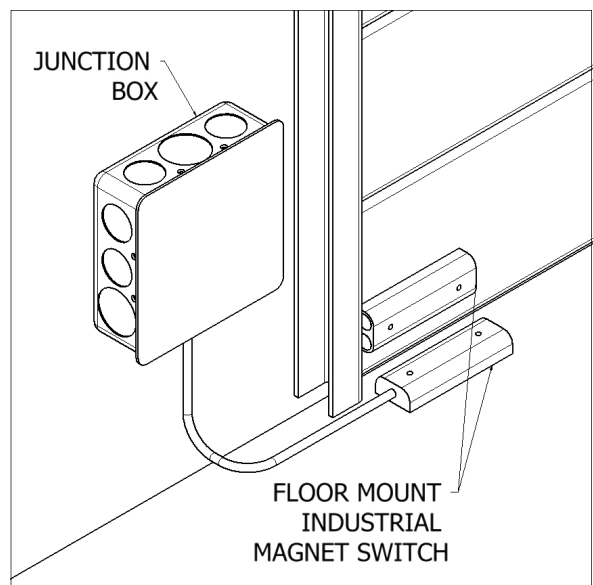

FIG. 4

Bracket Installation

1. Side Extension Plates: For doorways wider than the air curtain, use combination of Side Extension Plates and Adjustable Mounting Brackets. (FIG. 5)

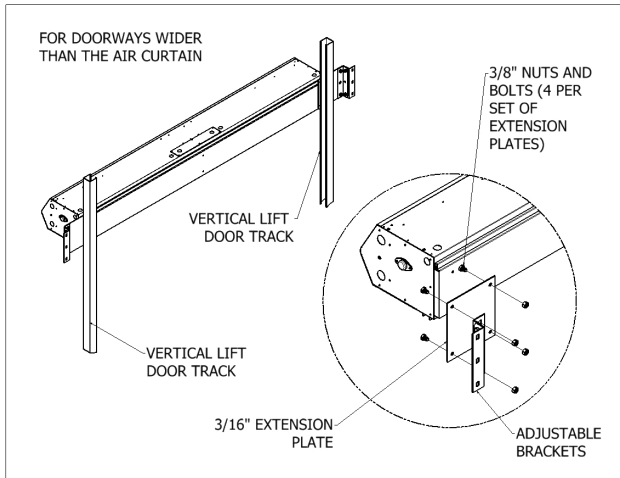

FIG. 5 (LPV Shown)

2. Adjustable Mounting Brackets: For installation of air curtain over drum-style roll-up door, use Extended Wall Mounting Brackets. (FIG. 6)

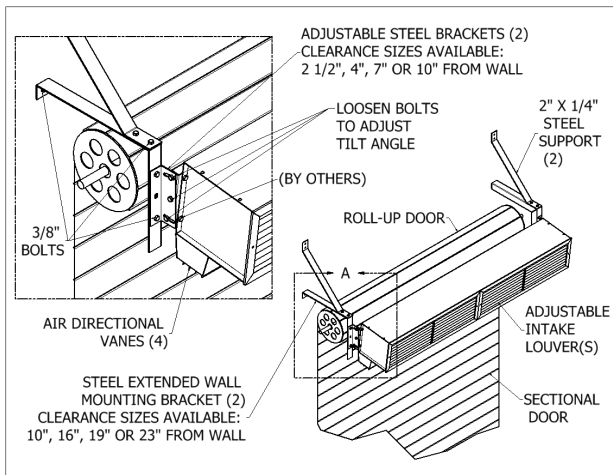

FIG. 6 (STD Shown)

3. Extended Wall Mounting: For Tandem Mounting of air curtain over sectional style door, use either wall mounting angle brackets or threaded rods.
4. Top Mounting Brackets: For overhead installation of units, use in conjunction with the threaded holes provided on top of unit.

Note: Angle brackets, threaded rods and I Beams are provided by others. (FIGS. 7 & 8) All optional brackets are not available for WMI/WMH and BD Series.

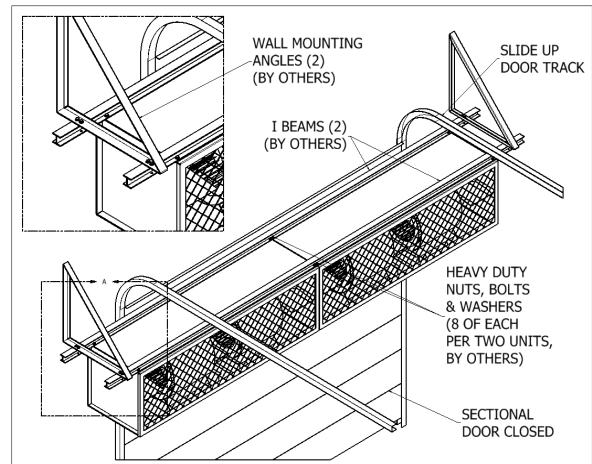

FIG. 7 (WMI/WMH Shown)

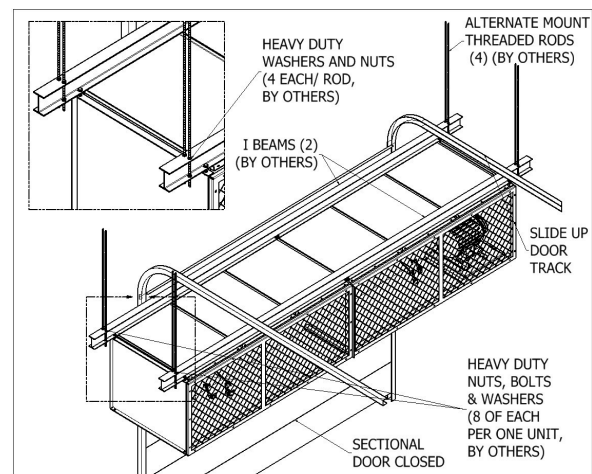

FIG. 8 (BD Shown)



atmosphere is everything

14716 S. Broadway St., Gardena, CA 90248

(310) 532-1555 • (800) 421-1266

Fax: (310) 324-3030

www.marsair.com