

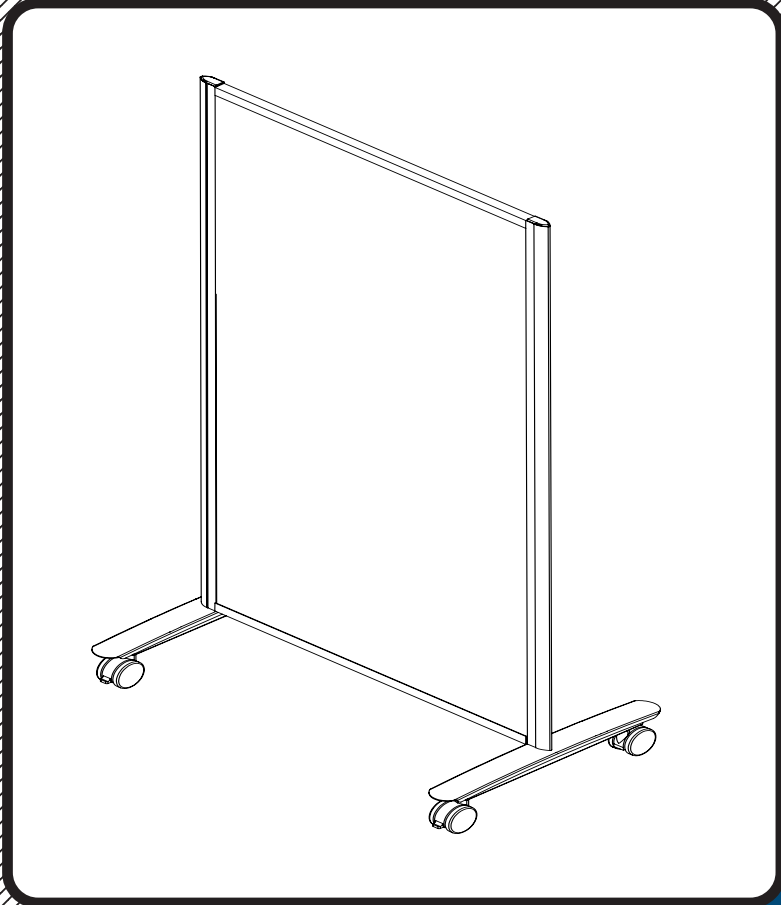









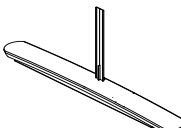
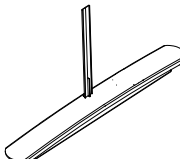

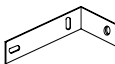

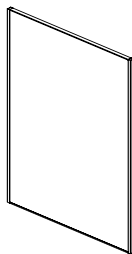
**Lumina Room Divider  
BLT-27578, BLT-74861**

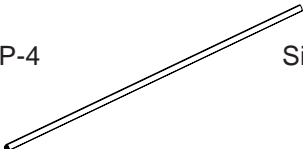

**Assembly Instructions**

# Lumina Room Divider

Part	Drawing	Description	Qty	Part	Drawing	Description	Qty
P-1L		Left Foot	1 EA	<b>Hardware List</b>			
P-1R		Right Foot	1 EA	A		Locking Caster	2 EA
P-2		Foot Bracket	2 EA	B		Non-Locking Caster	2 EA
P-3		Panel	1 EA	C		Top Cap	2 EA
P-4		Side Extrusion	2 EA	D		Foot Bracket Screw	2 EA
				E		Phillips Head Screw	8 EA
				F		Allen Wrench	1 EA
				G		Caster Wrench	1 EA
				H		Lock Washer	4 EA
				<b>Tools Required:</b> Phillips Screw Driver			

## Important

The Balt product you have purchased is guaranteed against material and workmanship defects. This guarantee extends 1 year from date of purchase. Should this product fail to function satisfactorily under normal use due to defect or imperfection, the defective part or product will be replaced. Damage caused by common carriers during shipment is not included in this guarantee. Do not use unless all screws are tight. At least every six months, check all screws to be sure they are tight. If parts are missing, broken, damaged, or worn, stop use of the product until repairs are made by your dealer using factory authorized parts.

**This guarantee sets forth all applicable guarantees and remedies. No other warranty, expressed or implied shall apply. Failure to follow instructions found in Important Information Section of Owner Sheet shall void the guarantee. Consequential or incidental damages and or costs are not refundable.**

**READ THROUGH INSTRUCTIONS FROM BEGINNING TO END BEFORE STARTING TO ASSEMBLE UNIT.**

**To Assemble:**

- 1.) Identify and separate all the parts and hardware.
- 2.) Insert and attach one Foot Bracket (P-2) to the Right Foot (P-1R) using one Foot Bracket Screw (D) as shown in Illustration # 1. Repeat this step for the Left Foot (P-1L).

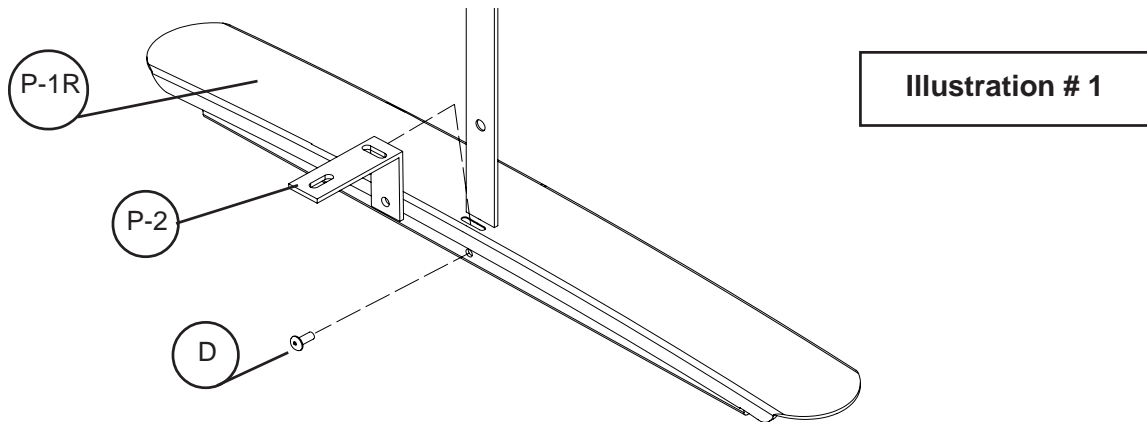

- 3.) Insert the Right Foot and Left Foot assemblies into Panel (P-3). Slide the vertical brace on each Foot assembly into the panel's aluminum sides. Connect each Foot assembly to the Panel (P-3) using four Phillips Head Screws (E) as shown in Illustration # 2. Do not tighten screws until all screws are installed.

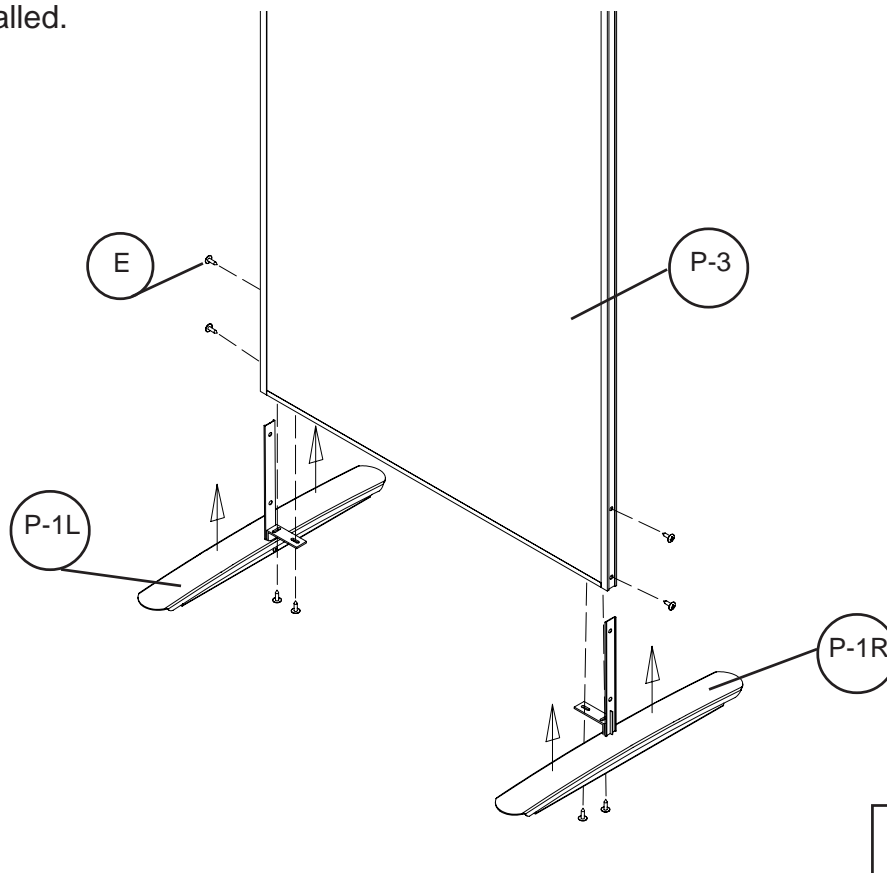

- 4.) Place a Lock Washer (H) on each Caster's threaded stem before attaching. Screw in two Locking Casters (A) and two Non-Locking Casters (B) into the Right Foot and Left Foot as shown in Illustration # 3. Tighten casters using Caster Wrench (G).

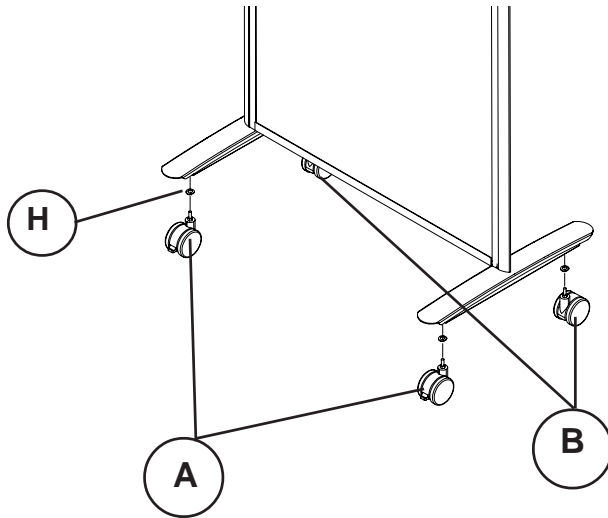
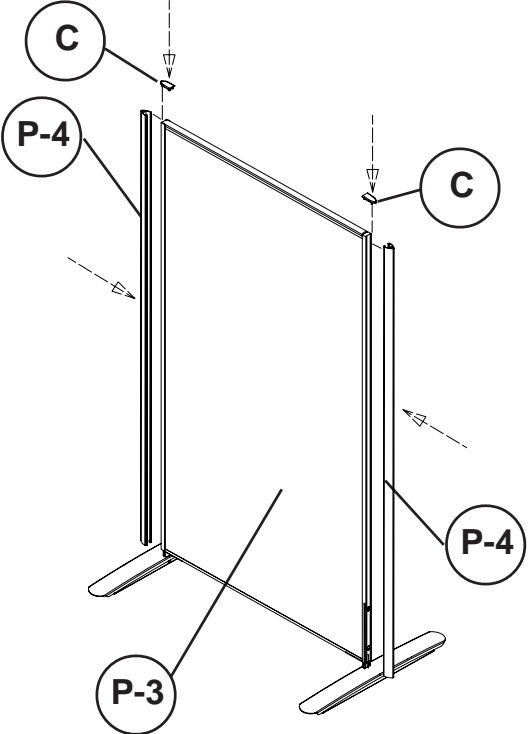

Illustration # 3

- 5.) Align the Side Extrusion (P-4) with the top of Panel (P-3) and snap on each side as shown in Illustration # 4. Finish the top by snapping in a Top Cap (C) into each Side Extrusion (P-4).

Illustration # 4



*Should you require assistance during assembly,  
please call our Customer Service Department  
Monday - Friday 8 a.m. - 5 p.m.  
Central Standard Time  
Toll-Free Customer Service  
**1-800-749-2258***