

**Contents**

	Page
Receiving Procedures. . . . .	1
Warranty. . . . .	1
Safety Information. . . . .	1 - 3
Description. . . . .	3
Operating Instructions. . . . .	4
Maintenance. . . . .	5
Handling Flammable Liquids. . . . .	6
Parts List and Diagram. . . . .	7 - 8

**Operator's Manual  
for Morse Drum Pump Models  
26, 27-1AE, 27-4AV,  
28-5BV and 28-6BE**



**Receiving Procedures**

Every Morse drum handler is inspected prior to shipping. However, damage may be incurred during transit.

- Check for visible damage. If you choose to accept damaged freight, always sign noting the damage on the **Bill of Lading**.
- Document the damage and have the truck driver sign. We recommend keeping a digital camera at your receiving dock for this purpose.
- Open packages expeditiously to check the condition of the goods. There is only a 24 hour window to notify the carrier of any concealed damage.
- Immediately **report all damage to the shipping company!** Then you may contact Morse for assistance with your freight claim.
- Morse Manufacturing will not be held responsible for any damaged freight that is not signed for as damaged.
- Depending on model number and options ordered the following parts are shipped loose in the carton and should be checked before destroying the carton and packaging material. See the drawing in page 7 to help identify these parts.
  1. 1 bung adaptor (item 32)
  2. 1 clamp (item 31)
  3. 1 hose (item 17), complete with: 1 hose adaptor (item 21)
  4. 1 nozzle (item 15), 2 hose clamps (item 16)
  5. 1 suction tube (item 36)
  6. 1 extension tube (item 34)
  7. 1 coupling (item 35)
  8. 1 discharge spout

**Limited 1 Year Warranty**

Morse drum handling equipment is guaranteed against defects in workmanship or materials for one year when used properly within its rated capacity. Warranty does not cover wear from normal use or damage from accident or abuse. Motors and other purchased parts carry the warranties of their manufacturers. For warranty claims, contact your Morse Dealer to obtain a return authorization number, and for return freight advice. Return freight must be prepaid.

In all instances, liability is limited to the purchase price paid or to repairing or replacing the product. Customer assumes liability for any modifications, unauthorized repairs or parts substitution.

**Safety Information**

While Morse Manufacturing Co. drum handling equipment is engineered for safety and efficiency, a high degree of responsibility must be placed upon the machine operator to follow safe practices, based primarily on common sense, upon which true safety depends.

Failure to follow the safety precautions in this manual can result in personal injury or property damage. Observe the same precautions as with similar machinery where carelessness in operating or maintenance is hazardous to personnel. Carefully read the safety precautions below and throughout this manual.

Review the Material Safety Data Sheet(s) for the material(s) in the drum(s) and take all necessary precautions. Safety shoes, work gloves, hard hat and other personal protective devices are recommended.

Prior to initial use, inspect all moving parts. Inspect pump for proper operation. Perform necessary test, inspections, operator training, etc.

### Safety Information (continued)



**DANGER** - Indicates a situation which, if not avoided, will result in serious injury or death. This signal word is limited to the most extreme situations.



**WARNING** - Indicates a situation which, if not avoided, could result in serious injury or death.



**CAUTION** - Indicates a situation which, if not avoided, can result in damage to the machine.



**WARNING** - Do Not Modify the Unit. Under no circumstances should any modifications be made to the Morse machinery without factory authorization. Any modifications may void the warranty. This machine was designed to perform a specific job and alterations may result in injury to operator or machine.



**WARNING** - No Loose Fitting Clothing. Wear close-fitting clothing and safety equipment appropriate to the job. Loose fitting clothing may become caught on the machinery and cause severe personal injury.



**CAUTION** - Wear safety shoes with non-slip soles and hard toe protection.



**CAUTION** - DO NOT allow drum to impact on floor, ground, or dumping station, etc.



**WARNING** - Verify the chemical compatibility of the materials of your pump with the liquid you want to pump. If you are uncertain regarding chemical compatibility, contact your dealer for applications assistance and request a copy of our Corrosion Resistance Charts. Do not use a pump that is not chemically compatible with the liquid you intend to pump or serious bodily injury, death, fire, explosion or environmental damage could result. See [Chemical Compatibility Chart](#) online.

## Safety Precautions

- A. This manual contains important information for the safe and proper operation of this pump. Read it THOROUGHLY before operating or installing the pump.
- B. USE ONLY ORIGINAL FACTORY REPLACEMENT PARTS.
- C. When pumping flammable liquids, ensure adequate ventilation to prevent explosive build up of fumes. Pumping should always be done in a "NO SMOKING" area. Approved fire extinguishers, in good condition, should be available for fire suppression.
- D. Containers holding flammable liquids should be grounded, and portable containers bonded, to prevent explosion hazards from static electricity charges. See page 6.
- E. Operators should be properly instructed on operating procedures and safety precautions.
- F. Do not use torches or apply fire or flame to this pump for any reason.
- G. When pumping corrosives use personal protection such as rubber gloves, aprons, eye shields and adequate ventilation. Consult chemical manufacturer for additional cautions.
- H. Do not overtighten nonmetallic threaded fittings. One full turn past hand tight is usually enough to prevent leakage. One roll of teflon tape is provided and should be used on all threaded joints.
- I. Inspect the siphon breaker regularly to ensure proper operation. To test siphon breaker, lay hose on ground with nozzle in a suitable container to hold the liquid. Operate the handle until liquid flows from the nozzle. Stop pumping: the hose should drain and the flow stop. If flow continues without moving the handle, place the nozzle in its hanger to stop the flow. Then inspect the siphon breaker vent for blockage or freezing. Flush the vent with water, or if pumping petroleum products, use clean product.

TO PREVENT SPILLING LIQUID WHEN REMOVING PUMP FROM BARREL, OBSERVE THE FOLLOWING PRECAUTIONS:

1. Straighten discharge hose and hold it below the pump discharge. Allow hose to drain into a container.
2. Loosen stainless steel clamp (item 31).
3. Pull pump from bung adaptor and allow suction tube to drain back to the barrel. Lay pump flat with handle up. Place container under nozzle. Operate handle until liquid is clear from pump housing.
4. Allow discharge hose to drain. Place the hose nozzle in its hanger. If pump will not be installed in a new barrel, any caustic or corrosive chemicals should be flushed with fresh water internally and externally to prevent personal injury during handling. ANY PUMP USED TO TRANSFER FLAMMABLE LIQUIDS MUST BE STORED IN A WELL VENTILATED AREA AFTER USE.

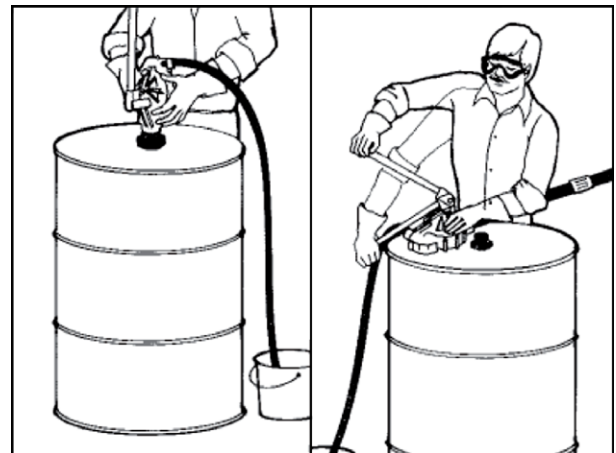

Figure 3

## Description

- A. If you have not checked the chemical compatibility of your pump with the liquid, do it now before using the pump! The pump is equipped in one of several ways. Compare your model number with the model number chart immediately on page 5. This will tell you what materials make up your pump. Consult the factory for any chemical applications. A chemical resistance chart is packed with the pump. [Chemical Compatibility Chart](#) is also online.
- B. The pump handle can be easily positioned either up for normal use, or down, allowing the pump to be elevated. This would be convenient for example when pumping from a truck mounted drum or barrel. See Pump Operating Instructions step F on page 4.
- C. A siphon breaker is built into the pump discharge. This prevents siphoning from the drum if the hose drops from its hanger. It also allows the hose to drain completely after pumping.
- D. The barrel is vented by 4 relief channels molded into the bung adaptor. This prevents drawing a vacuum in the barrel.
- E. The suction tube and extension tube supplied are cut to fit a standard 55-gallon drum. The suction tube has a bevel cut at one end and is threaded at the other end.

The extension tubes are threaded at both ends. Extra extension tubes and couplings may easily be used for deeper vessels such as tanks. Maximum suction lift is 15 feet.

1. A 55-gallon drum on end requires 1 extension tube, 1 coupling and 1 suction tube threaded together.
2. To use the side bung hole on a 55-gallon drum, thread together one extension tube, one coupling and a 5" length of suction tube. The plastic tube can easily be cut with a hacksaw. Make the cut at an angle. DO NOT CUT THE THREADED END.
3. For 275 gallon tanks, thread together two extension tubes and one suction tube.

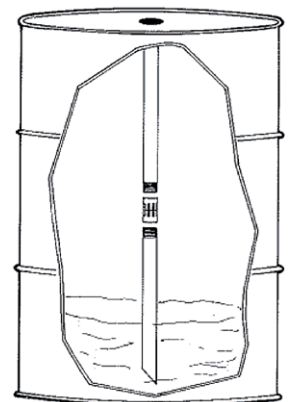
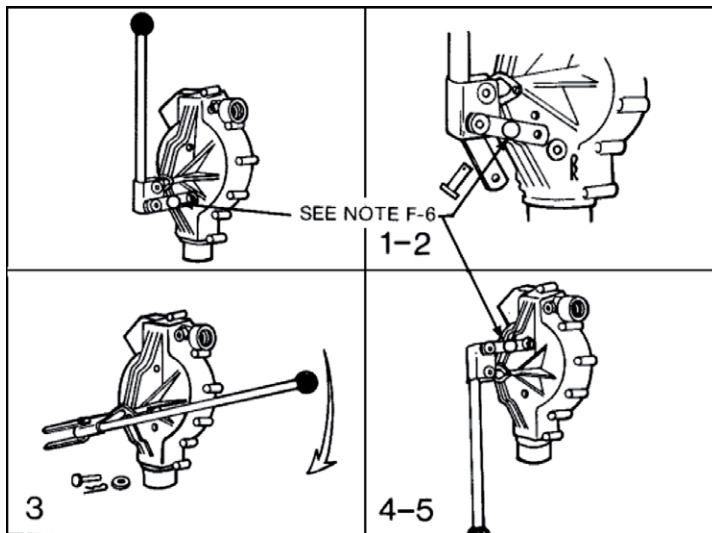
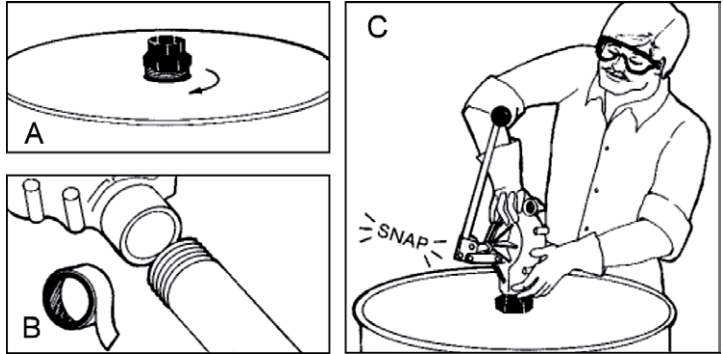

Figure 1

### Pump Operating Instructions

#### FOR EASY INSTALLATION FOLLOW THESE STEPS IN THE ORDER SHOWN.

- A. Screw the bung adaptor into the drum or barrel. Be sure not to overtighten (Refer to Safety Precautions step H on page 3).
- B. Install supplied clamp loosely around bung adaptor.
- C. Thread appropriate length of suction tube and extension tube(s) into pump section. Use teflon tape provided (Refer to Safety Precautions step H on page 3).
- D. Install pump and tubing into bung adaptor by pushing straight down firmly. Housing will snap in place. Tighten the clamp (item 31). Screw hose and adaptor or discharge spout into pump body.



Two Position Pump Handle

- E. Caution: When pumping from a lined drum, order part item 58-0069. This is a flexible suction tube to prevent damage to the liner.
- F. The handle position can be changed with the following steps.
  1. Remove hairpin clip (item 6) from clevis pin (item 7).
  2. Remove clevis pin from housing to free links (item 8).
  3. With links clear of housing, rotate handle 1/2 turn to new position.
  4. Install clevis pin through the links and the opposite hole in housing.
  5. Install hairpin clip through the hole in the clevis pin. Ensure the flat washer (item 4) is installed between the hairpin clip and the link.
  6. CAUTION: This hole is used for security lock only.
- G. Remove hose from hanger and place nozzle in container. Operate handle to prime the pump. 3-6 strokes are required under most conditions. After the pump is primed it will deliver about one gallon for every four full strokes (backward and forward).

### Trouble Shooting Guide

#### A. pump will not prime

1. Clogged suction. Check that the suction tubes are clear and that the screen filter is not dirty or clogged. Use a pair of needle nose pliers or a stiff piece of wire to pull the suction screen from housing. Clean it, if necessary, and push it gently back into the housing or with a finger or blunt rod.
2. Air leakage. Check that the connection to housing, extension tube and suction tube are threaded tightly and sealed with teflon tape (Refer to Safety Precautions step H on page 3).
3. Piston leakage. Verify that the teflon ring fits snugly in bore and is not cut or excessively worn.
4. Valve leakage. Inspect poppet valves for weak springs or clogging. If pump was recently disassembled VERIFY PROPER POSITION OF VALVE SEATS (Refer to Maintenance step B.1. on page 5).
5. Gasket leaks. Inspect for torn gasket (item 18), poor fit or loose coverplate bolts (item 20).

#### B. Not Enough Flow

1. Check items A. 1-5.
2. Check discharge hose for clogging or pinching. Verify that the nozzle is not clogged.
3. Check that piston is travelling its full stroke and the linkage has not bound or jammed.

General Guide to Morse Drum Hand Pump Applications						
Pump Model item	Construction (All have some T316SS)	O-Ring Mtl.	Gasket Mtl.	Hose Mtl.	Suction Tube	Compatible Liquids* (General Guide)
26	polyester	viton	cork-nitrile	PVC	polyester	petroleum products, lube oils*
27-1AE	polyester	EPDM	EPDM	EPDM	polyester	methyl alcohol, ethyl alcohol*
27-4AV	polyester	viton	viton	cross linked polyeth.	polyester	some naphthas*, some aromatics*
28-5BV	ryton	viton	viton	cross linked polyeth.	teflon	some chlorinated solvents, acids, aromatics, xylene*
28-6BE	ryton	EPDM	EPDM	EPDM	teflon	some acids, caustics, ketones, acetates*
* NOTE: General guide only. Final determination of suitability for use intended or manner of use is responsibility of the user. Consult Morse for advice on specific liquids if they are not shown here. Please furnish chemical names.						
** NOTE: Chemicals may be hazardous. It is the user's responsibility to take appropriate safety and protective measures. Specifications subject to change without notice.						



**CAUTION:** Chemical compatibility of a pump should be CHECKED FOR EACH LIQUID BY CHEMICAL NAME. See [Chemical Compatibility Chart](#) online.

## Maintenance

### Use only original factory replacement parts

#### A. Disassembly

1. Remove hose (item 17) from housing. Unscrew suction and/or extension tubes (items 34 and 36).
2. Remove hex nuts (item 22) and screws (item 20) from housing. Remove cover plate and gasket (items 19 and 18), being careful not to damage the gasket.
3. Remove large and small valve assemblies (items 24 and 23) and inspect for broken or weak springs, or damaged or clogged valves.
4. Remove hairpin clip (item 5), washer (item 4) and clevis pin (item 3) which hold the handle (item 2) to the piston rod. Remove hairpin clip (item 6), flat washer (item 4) and clevis pin (item 7) from links (item 8) at the pump housing (item 37). Remove pin (item 3) from piston rod and set handle aside. Slide piston assembly (item 28) from the housing.
5. Inspect teflon ring (item 30) in piston groove. It must extend about 1/32nd above the edge of the piston to seal properly. If the ring is worn flush with the piston edge it must be replaced. When removing the teflon ring be careful not to damage the piston if tools are being used. Always replace the O-ring (item 29) when replacing the teflon ring. The rubber O-ring is compressed over time, reducing its ability to seal.
6. Inspect piston bore in housing (item 37) for wear. Any gouging or scraping would indicate that the liquid being pumped contains abrasives. Replace the housing and teflon ring if the surfaces are gouged or worn.
7. Remove the two screws (item 9) that hold the retaining plate (item 10) to the housing. Remove plate to expose piston rod O-ring (item 11). Replace O-ring if worn.

#### B. Reassembly

1. Install the two small valve assemblies (item 23) in the housing first, then the two large assemblies (item 24). There is a small tab molded into the valve seats which fits a guide channel in the housing. This prevents installing the valve seats backwards. If the tabs are broken, please note the following.
  - a. The suction valve seats (lower two) should have their springs facing each other when installed.
  - b. The discharge valve seats (upper two) should have springs facing away from each other.
2. Install piston rod O-ring (item 11). Install retainer plate (item 10) with the groove facing AWAY from the pump housing. Ensure piston (item 28) has O-ring (item 29) and teflon ring (item 30) installed. Teflon ring will stretch enough to install by hand (tools may damage the piston). Slide piston rod into housing. The teflon ring will catch on the edge of the housing while pushing the piston into the bore. To help seat the ring, turn piston slowly while pushing ring into the groove with fingers. DO NOT FORCE PISTON.
3. Inspect the cover plate gasket (item 18) for damage.
4. Lay coverplate and gasket on housing and install screws (item 20) and hex nuts (item 22). Tighten firmly enough to compress gasket.
5. Install short clevis pin (item 3) through the piston rod and handle securing with washer (item 4) and hairpin clip (item 5). Install clevis pin (item 7), flat washer (item 4) and links (item 8) at the pump housing.
6. Install hose and suction extension tubes as required. Refer to Safety Precautions step I. on page 3, and Description step E. on page 3.



### General Safety Information for Handling Flammable and Combustible Liquids



**WARNING** - When using a hand pump to fill cans, drums or other portable or fixed containers with flammable or combustible liquids such as gasoline, both container being pumped from and the container being pumped to must be effectively BONDED and GROUNDED to prevent discharge of sparks of static electricity which could cause explosion.

BONDING is the electrical interconnection between containers (such as a drum and a receiving can). Bonding must be completed BEFORE pumping begins. See diagrams below.

GROUNDING is the electrical connection between a container and a "constant ground". A "constant ground" would be a metal pipe or rod in contact with the earth. An underground tank and piping connected to it would be inherently grounded by nature of the installation. See diagrams below.

Both BONDING and GROUNDING of containers of flammable liquids are required under U.S. Government OSHA regulations and National Fire Protection Association Code 77, Static Electricity.

Consult factory for specific liquid handling recommendations.

High quality BONDING and GROUNDING wires are available through drum accessory suppliers.

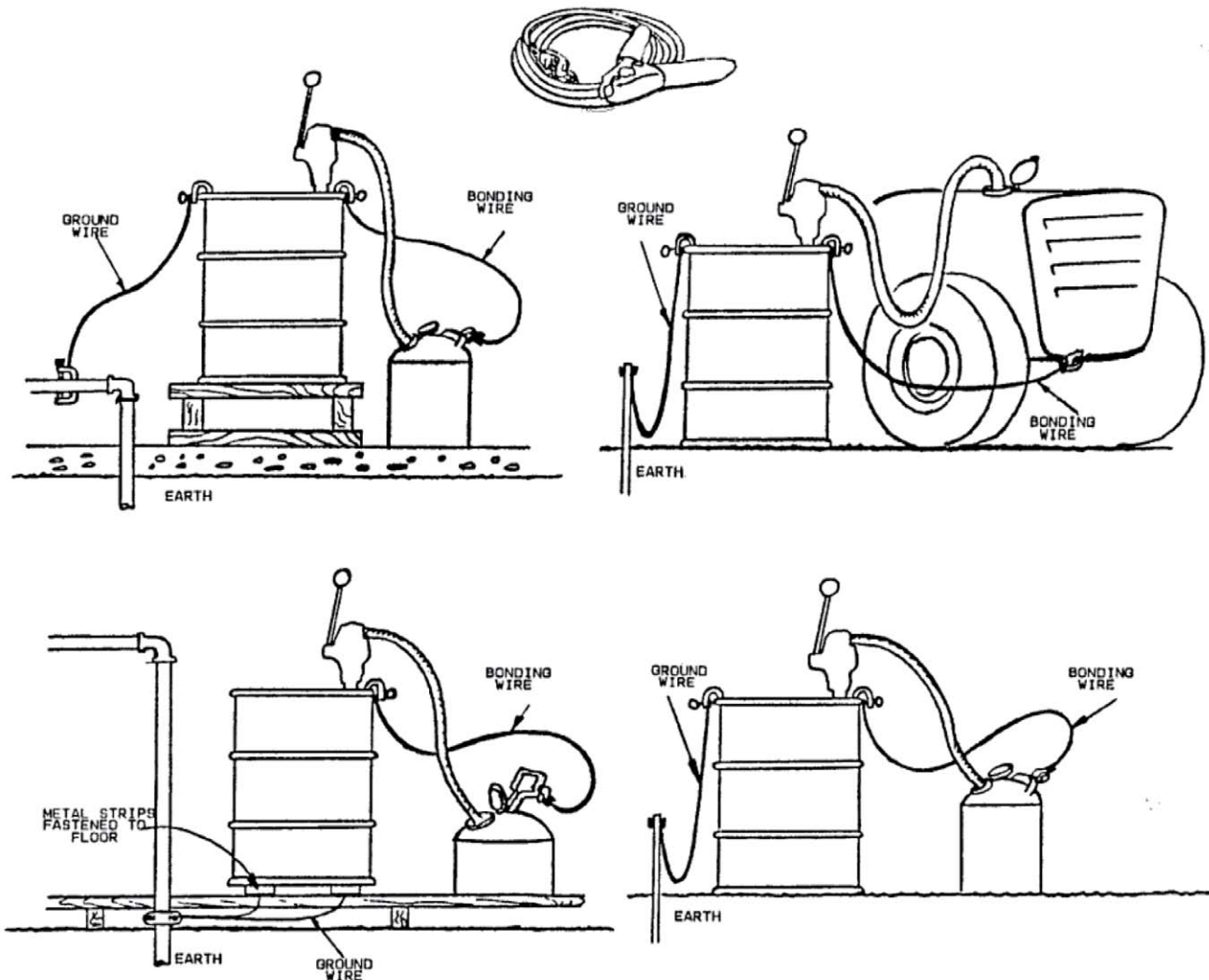

Drum Pump Repair Kits (Valves and Gaskets)		
Pump Model #	Repair Kit #	Description
26	5867-P	Cork / Nitrile Gasket, Viton O-Rings, Polyester Valves, Teflon Piston Ring
27-1AE	5869-P	EPDM Gasket and O-Rings, Polyester Valves, Teflon Piston Ring
27-4AV	5866-P	Viton Gasket and O-Rings, Polyester Valves, Teflon Piston Ring
28-5BV	5865-P	Viton Gasket and O-Rings, Halar Valves, Teflon Piston Ring
28-6BE	5868-P	EPDM Gasket and O-Rings, Halar Valves, Teflon Piston Ring

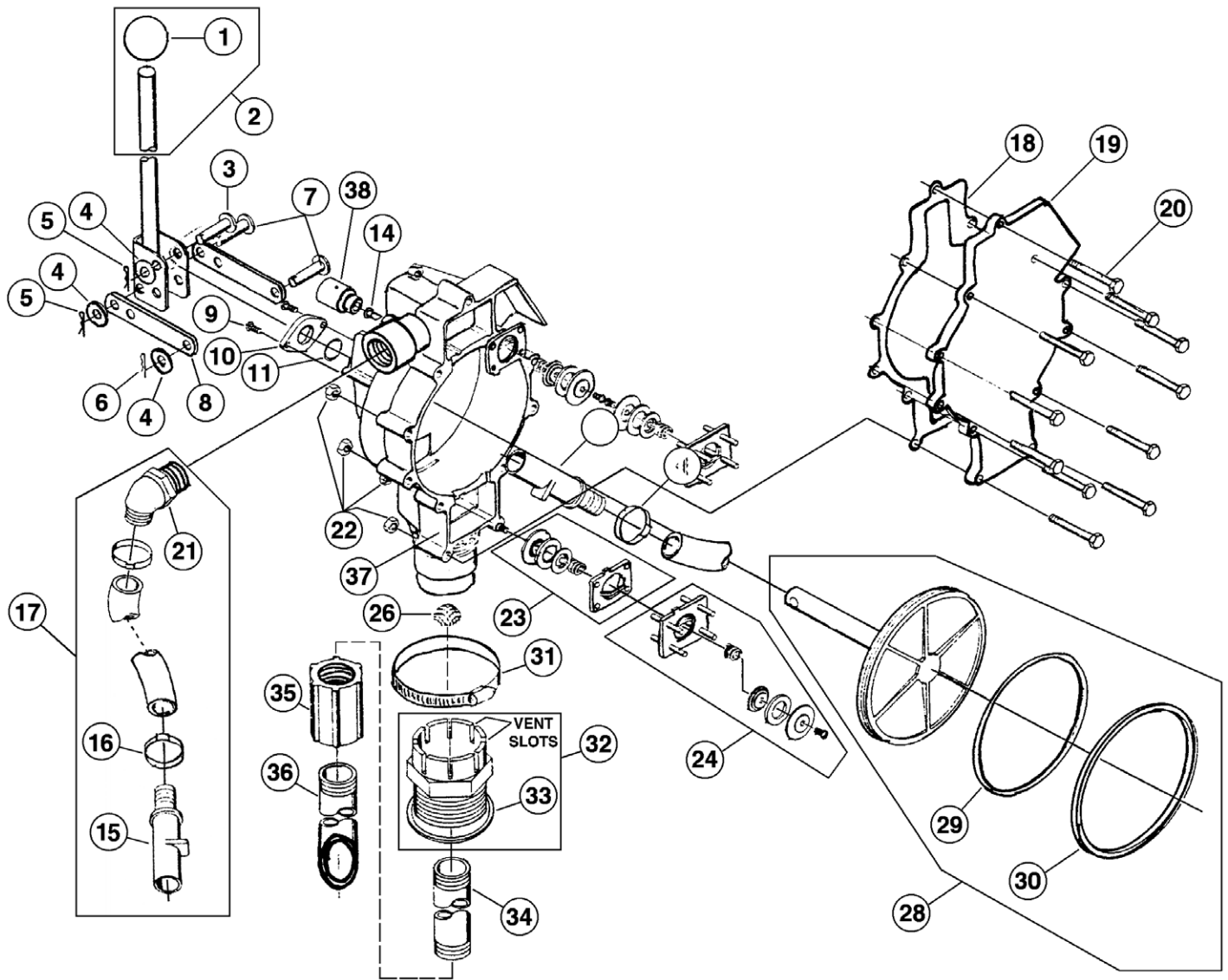



The Specialist In Drum Handling Equipment

## Drum Pumps

ITEM	QTY.	MODEL	PART #	DESCRIPTION
1	1	ALL PUMP MODELS	1049-40	KNOB, POLYPROPYLENE, PAC
2	1	ALL PUMP MODELS	1050-01	HANDLE ASM, PUMP, PAC
3	1	ALL PUMP MODELS	1053-00	PIN, CLEVIS 5/16 X 1-1/8, PAC
4	4	ALL PUMP MODELS	1380-90	WASHER, FLAT, NYLON, PAC
5	2	ALL PUMP MODELS	1379-00	CLIP, HAIRPIN, SMALL, PAC
6	1	ALL PUMP MODELS	1027-00	CLIP, HAIRPIN, LARGE, PAC
7	2	ALL PUMP MODELS	1031-00	PIN, CLEVIS, 5/16 X 1-1/4 PAC
8	2	ALL PUMP MODELS	1052-00	LINK, PLATED STEEL, PAC
9	2	ALL PUMP MODELS	1348-10	SCREW, 10-14 X 3/4 SS, PAC
10	1	26, 27-1AE, 27-4AV	1032-30	PLATE, RETAINING, PE, PAC
10	1	28-5BV, 28-6BE	1032-90	PLATE, RETAINING, HALAR, PAC
11	1	27-1AE, 28-6BE	1030-72	O-RING, PISTON ROD, EPDM PAC
11	1	26, 27-4AV, 28-5BV	1030-73	O-RING, PISTON ROD, VITON PAC
14	1	27-1AE, 28-6BE	1040-72	VACUUM BREAKER, EPDM, PAC
14	1	26, 27-4AV, 28-5BV	1040-73	VACUUM BREAKER, VITON, PAC
15	2	26, 27-1AE, 27-4AV	1325-30	NOZZLE, NO-LEAD, PE, PAC
15	1	28-5BV, 28-6BE	1325-90	NOZZLE, NO-LEAD, HALAR, PAC
16	2	ALL PUMP MODELS	1044-12	CLAMP, HOSE, CRIMPED, SS, PAC
17	1	26, 27-1AE, 27-4AV	1342-02	HOSE, PVC W/ PE NOZZLE, PAC
17	1	28-5BV, 28-6BE	1342-92	HOSE, PVC, HALAR NOZZLE, PAC
17	1	26, 27-1AE, 27-4AV	1342-04	HOSE, NITRILE, PE NOZZLE, PAC
17	1	28-5BV, 28-6BE	1342-94	HOSE, NITRILE, HALAR NOZZLE
17	1	26, 27-1AE, 27-4AV	1342-05	HOSE, EPDM W/ PE NOZZLE
17	1	28-5BV, 28-6BE	1342-95	HOSE, EPDM, HALAR NOZZLE, PAC
17	1	26, 27-1AE, 27-4AV	1342-07	HOSE, CLPE W/ PE NOZZLE, PAC
17	1	28-5BV, 28-6BE	1342-97	HOSE, CLPE, HALAR NOZZLE, PAC
18	1	27-1AE, 28-6BE	1204-72	GASKET, COVERPLATE, EPDM, PAC
18	1	27-4AV, 28-5BV	1204-73	GASKET, COVERPLATE, VITON, PAC
18	1	26	1204-90	GASKET, COVERPLATE, CORK, PAC
19	1	26, 27-1AE, 27-4AV	1209-30	COVERPLATE, PE, RED, PAC
19	1	28-5BV, 28-6BE	1209-60	COVERPLATE, RYTON, BLACK, PAC
20	11	26, 27-1AE, 27-4AV	1206-00	SCREW, 1/4-20 X 2, PAC
20	11	28-5BV, 28-6BE	1206-10	SCREW, 1/4-20 X 2 SS, PAC
21	1	26, 27-1AE, 27-4AV	1214-30	ADAPTER, HOSE, PE, 60DEG, PAC
21	1	28-5BV, 28-6BE	1214-90	ADAPTER, HOSE, HALAR 60DEG PAC
22	11	26, 27-1AE, 27-4AV	0721-00	NUT, 1/4-20 HEX, PLATED, PAC

ITEM	QTY.	MODEL	PART #	DESCRIPTION
22	11	28-5BV, 28-6BE	0721-10	NUT, 1/4-20 HEX, SS, PAC
23	2	27-1AE	1340-02	VALVE ASM, SMALL, PE EPDM PAC
23	2	26, 27-4AV, 28-5BV	1340-03	VALVE ASM, SMALL PE VITON PAC
23	2	28-6BE	1340-92	VALVE ASM SMALL, HALAR, EPDM
23	2	28-6BE	1340-93	VALVE ASM SMALL, HALAR VITON
24	2	27-1AE	1341-02	VALVE ASM LARGE, PE EPDM, PAC
24	2	26, 27-4AV, 28-5BV	1341-03	VALVE ASM, LARGE PE VITON, PAC
24	2	28-6BE	1341-92	VALVE ASM LARGE, HALAR EPDM
24	2	28-6BE	1341-93	VALVE ASM LARGE, HALAR VITON
26	1	ALL PUMP MODELS	1038-10	SCREEN, FILTER, SS, PAC
28	1	27-1AE	1338-02	PISTON ASM, PE, EPDM, PAC
28	1	26, 27-4AV, 28-5BV	1338-03	PISTON ASM, PE, VITON, PAC
28	1	28-6BE	1338-92	PISTON ASM, HALAR, EPDM, PAC
28	1	28-6BE	1338-93	PISTON ASM, HALAR, VITON, PAC
29	1	27-1AE, 28-6BE	1029-72	O-RING, PISTON, EPDM, PAC
29	1	26, 27-4AV, 28-5BV	1029-73	O-RING, PISTON, VITON, PAC
30	1	26, 27-1AE, 27-4AV	1028-90	RING, PISTON, TEFLON, PAC
30	1	28-5BV, 28-6BE	2024-90	RING, PISTON, TEFLON, THICKER
31	1	ALL PUMP MODELS	1056-10	CLAMP, BUNG ADAPTER, SS, PAC
32	1	26, 27-1AE, 27-4AV	1043-01	ADAPTER, PE, CORK NITRILE, PAC
32	1	28-6BE	1201-92	ADAPTER, HALAR W/ EPDM, PAC
32	1	27-4AV, 28-5BV, 28-6BE	1201-93	ADAPTER, HALAR W/ VITON, PAC
33	1	26, 27-1AE, 27-4AV	1381-90	GASKET, BUNG ADAPTER, PAC
33	1	28-6BE	1822-72	O-RING, BUNG ADAPTER, EPDM PAC
33	1	28-6BE	1822-73	O-RING, BUNG ADAPTER VITON PAC
34	1	26, 27-1AE, 27-4AV	1007-30	TUBE, EXTENSION, 16-1/2 PE PAC
34	1	28-5BV, 28-6BE	1007-90	TUBE, EXTENSION, 16-1/2 TEFLON
35	1	26, 27-1AE, 27-4AV	1055-30	COUPLING, 1" NPT PE, PAC
35	1	28-5BV, 28-6BE	1055-90	COUPLING, 1" NPT HALAR, PAC
36	1	26, 27-1AE, 27-4AV	1045-30	TUBE, SUCTION, 16-1/2 PE, PAC
36	1	26, 27-1AE, 27-4AV	2029-30	TUBE, SUCTION, 10-1/4" PE, PAC
36	1	28-5BV, 28-6BE	1045-90	TUBE, SUCTION, 16-1/2 TEFLON
37	1	26, 27-1AE, 27-4AV	1022-30	HOUSING, PUMP, HALAR, PAC
37	1	28-5BV, 28-6BE	1022-60	HOUSING, PUMP, RYTON, PAC
38	1	26, 27-1AE, 27-4AV	2022-30	PLUG, VENT, PE, PAC
38	1	28-5BV, 28-6BE	2022-90	PLUG, VENT, HALAR, PAC