

Contents

	Page
Receiving Procedures.	1
Warranty.	1
Safety Information.	1 - 2
Operating Instructions.	3
Maintenance.	3
Parts Lists and Diagrams.	4
Assembly Instructions.	5

**Operator's Manual
 for Morse Forklift-Karrier
 Model 81**

Serial Number 0813 to ____ (MMYY)

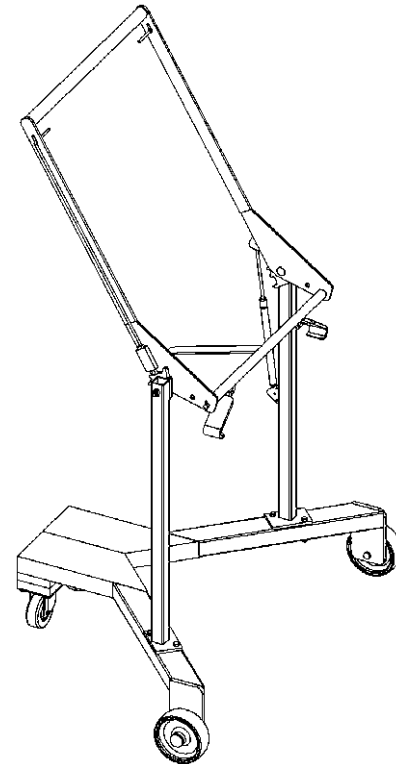

Receiving Procedures

Every Morse drum handler is inspected prior to shipping. However, damage may be incurred during transit.

- Check for visible damage. If you choose to accept damaged freight, always sign noting the damage on the **Bill of Lading**.
- Document the damage and have the truck driver sign. We recommend keeping a digital camera at your receiving dock for this purpose.
- Open packages expeditiously to check the condition of the goods. There is only a 24 hour window to notify the carrier of any concealed damage.
- Immediately **report all damage to the shipping company!** Then you may contact Morse for assistance with your freight claim.
- Morse Manufacturing will not be held responsible for any damaged freight that is not signed for as damaged.

Limited 2 Year Warranty

Morse drum handling equipment is guaranteed against defects in workmanship or materials for two years when used properly within its rated capacity. Warranty does not cover wear from normal use or damage from accident or abuse. Motors and other purchased parts carry the warranties of their manufacturers.

For warranty claims, contact your Morse Dealer to obtain a return authorization number, and for return freight advice. Return freight must be prepaid.

In all instances, liability is limited to the purchase price paid or to repairing or replacing the product. Customer assumes liability for any modifications, unauthorized repairs or parts substitution.

Safety Information

While Morse Manufacturing Co. drum handling equipment is engineered for safety and efficiency, a high degree of responsibility must be placed upon the machine operator to follow safe practices, based primarily on common sense, upon which true safety depends.

Failure to follow the safety precautions in this manual can result in personal injury or property damage. Observe the same precautions as with similar machinery where carelessness in operating or maintenance is hazardous to personnel. Carefully read the safety precautions below and throughout this manual.

Review the Material Safety Data Sheet(s) for the material(s) in the drum(s) and take all necessary precautions. Safety shoes, work gloves, hard hat and other personal protective devices are recommended.

Prior to initial use, inspect all moving parts. Perform necessary load test, inspections, operator training, etc.

Operator's Manual for Morse Model 81 Drum Spotter Serial Number 0813 to ____ (MMYY)

Safety Information (continued)



DANGER - Indicates a situation which, if not avoided, will result in serious injury or death. This signal word is limited to the most extreme situations.



WARNING - Indicates a situation which, if not avoided, could result in serious injury or death.



CAUTION - Indicates a situation which, if not avoided, can result in damage to the machine.



WARNING - The Drum Spotter is designed to handle one drum of the types listed at the top of page 3. Machine Description. DO NOT attempt to handle any other type of drum or object. DO NOT exceed the weight capacity of 800 Lb.



WARNING - Do Not Modify the Unit. Under no circumstances should any modifications be made to the Morse machinery without factory authorization. Any modifications may void the warranty. This machine was designed to perform a specific job and alterations may result in injury to operator or machine.



WARNING - No Loose Fitting Clothing. Wear close-fitting clothing and safety equipment appropriate to the job. Loose fitting clothing may become caught on the machinery and cause severe personal injury.



CAUTION - Wear safety shoes with non-slip soles and hard toe protection.



CAUTION: DO NOT allow drum to impact on floor, ground, etc.

Operator's Manual for Morse Model 81 Drum Spotter
Serial Number 0813 to ____ (MMYY)

Machine Description

The Model 81 Drum Spotter is designed to lift, transport, and palletize a 55-gallon steel, plastic or fiber drum with with suitable top rim. The drum must be 22" to 23.5" (56 to 60 cm) in diameter, and 34" to 36" (86 to 92 cm) tall. The maximum capacity is 800 Lb. The maximum pallet height is 6" (15 cm).



Operating Instructions

1. Roll the assembled Drum-Spotter to the drum. (Assembly instructions are on page 5.)
2. Grip the push-handle, squeeze both release rods and raise the handle to position lifting hooks below top rim of drum.
3. Roll the Drum-Spotter forward to drum.
4. Pull down the push-handle to raise the drum. The Drum-Spotter will hold up the drum and may be rolled away carrying the drum.
5. It is necessary to have a firm, two hand hold to lower the push-handle and squeeze the release rods. With both release rods squeezed, the handle will unlock and allow the weight of the drum to make the handle tend to rise. Apply sufficient force to allow the handle to rise slowly to control the descent of the drum.

Maintenance

1. Lubricate wheels and other moving parts periodically to maintain free action and reduce wear.
2. Tighten all nuts and bolts periodically except the two 1/2" carriage bolts (item 11) which should be just loose enough to permit a hinging motion of the stanchion and handle.

Parts Information

Worn or damaged parts must be replaced with the correct, genuine Morse parts. Please refer to the attached diagram and list. When ordering, specify model number, serial number, part numbers and descriptions.

Important

1. Review the Material Safety Data Sheet(s) for the material(s) in the drum(s) and take all necessary precautions. Safety shoes, work gloves, hard hat and other personal protective devices are recommended.
2. Please read all instructions *thoroughly* before attempting to operate your new MORSE drum handler.
3. The Model 81 has a maximum capacity ratings of 800 Lb. Drum-Spotters are made for various drum sizes and types as listed above. *DO NOT* exceed these ratings or an unsafe condition may result which could cause damage, excessive wear, or make the unit awkward or dangerous to handle.
4. Drum-Spotters are intended for lifting, moving, and holding drums. Drums may be lifted upright to or from the floor, pallets, dollies, scales, etc.
5. When loading, unloading, operating, or maintaining your MORSE drum handler, always use care and good judgment. Maintain secure footing and a firm hold. Keep hands and loose clothing away from all moving parts. Never allow anyone to be below any part of a raised drum handler or drum. Read operating instructions and review the pictures in the sales brochure before operation.

Operator's Manual for Morse Model 81 Drum Spotter Serial Number 0813 to ____ (MMYY)

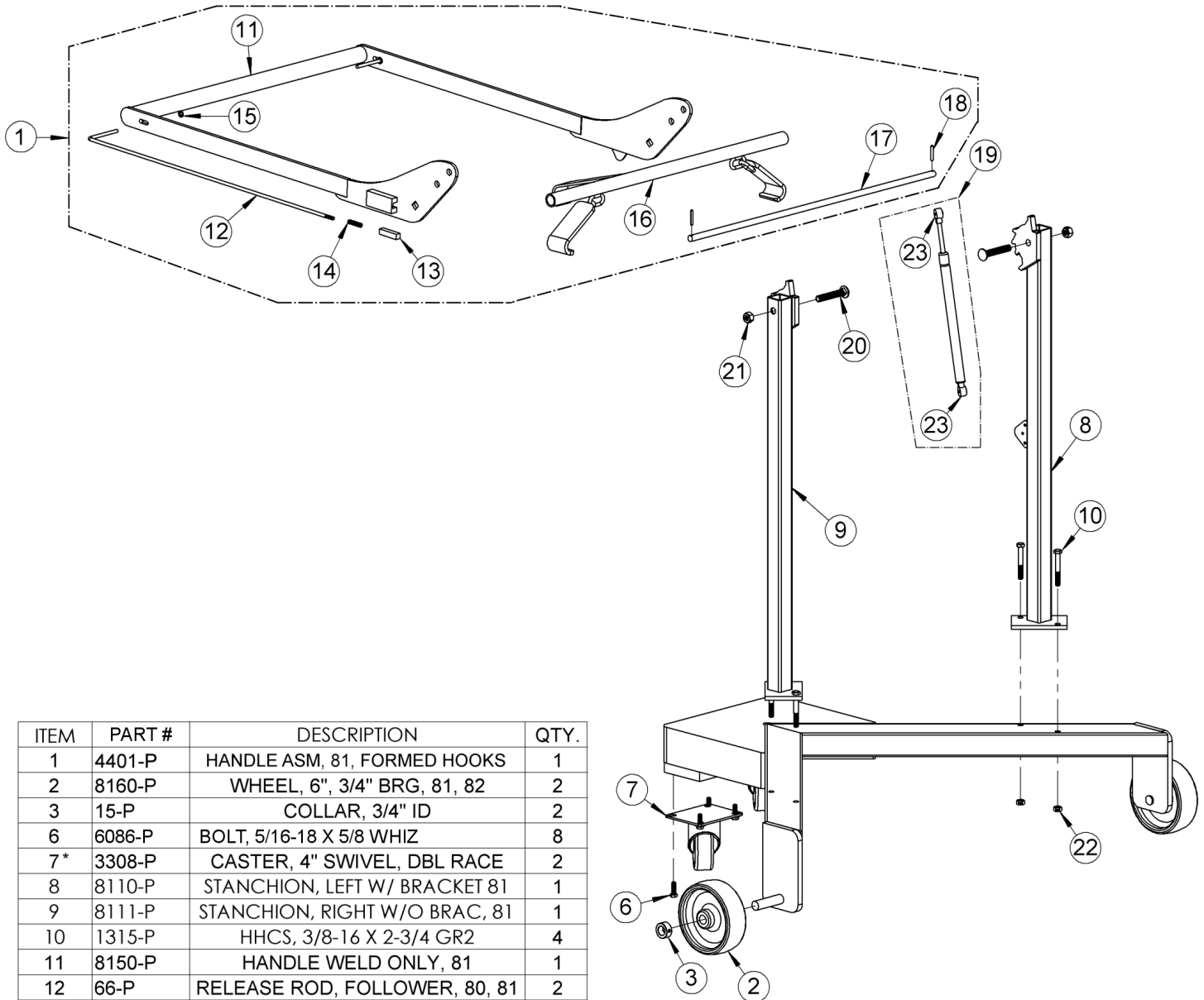

ITEM	PART #	DESCRIPTION	QTY.
1	4401-P	HANDLE ASM, 81, FORMED HOOKS	1
2	8160-P	WHEEL, 6", 3/4" BRG, 81, 82	2
3	15-P	COLLAR, 3/4" ID	2
6	6086-P	BOLT, 5/16-18 X 5/8 WHIZ	8
7*	3308-P	CASTER, 4" SWIVEL, DBL RACE	2
8	8110-P	STANCHION, LEFT W/ BRACKET 81	1
9	8111-P	STANCHION, RIGHT W/O BRAC, 81	1
10	1315-P	HHCS, 3/8-16 X 2-3/4 GR2	4
11	8150-P	HANDLE WELD ONLY, 81	1
12	66-P	RELEASE ROD, FOLLOWER, 80, 81	2
13	68-P	FOLLOWER, RATCHET, 80, 81	2
14	70-P	FOLLOWER SPRING, 80, 81	2
15	717-P	NUT, PUSH, 1/4"	2
16	4399-P	LIFT ASM, FORMED HOOK, 81	1
17	8128-P	ROD, LIFT HOOK SHAFT, 81	1
18	64-P	ROLL PIN, 3/16 X 1-1/4	2
19*	8165-P	SPRING, GAS, 81	1
20	806-P	BOLT, 1/2-13 X 3 CARRIAGE	2
21	810-P	NUT, 1/2-13 REV HEX LOCK	2
22	1169-P	NUT, 3/8-16 REV HEX LOCK	4
23*	8168-P	END FIT, BALL SOCKET, 8165-P	2

* Recommended spare parts

**Operator's Manual for Morse Model 81 Drum Spotter
Serial Number 0813 to ____ (MMYY)**

Assembly Instructions

1. Remove the base (item 23) from shipping container and carefully place on floor with wheels down.
2. Locate the left stanchion (item 13) with the ball type bracket welded in the center.
 - A. While standing behind the counterweight with the 6" wheels in front, place the left stanchion on the left base leg with ratchet facing inward.
 - B. Align the two holes in the stanchion with the left base leg holes and insert two 3/8-16 x 2-3/4 hex bolts (item 15 from the hardware bag).
 - C. Finger tighten two 3/8-16 lock nuts (item 16 from the hardware bag) onto bottom of bolts.
3. Locate the remaining right stanchion (item 14).
 - A. While standing behind the counterweight with the 6" wheels in front, place the right stanchion on the right base leg with ratchet facing inward.
 - B. Align the two holes in the stanchion with the right base leg holes and insert two 3/8-16 x 2-3/4 hex bolts (item 15 from the hardware bag).
 - C. Finger tighten two 3/8-16 lock nuts (item 16 from the hardware bag) onto bottom of bolts.

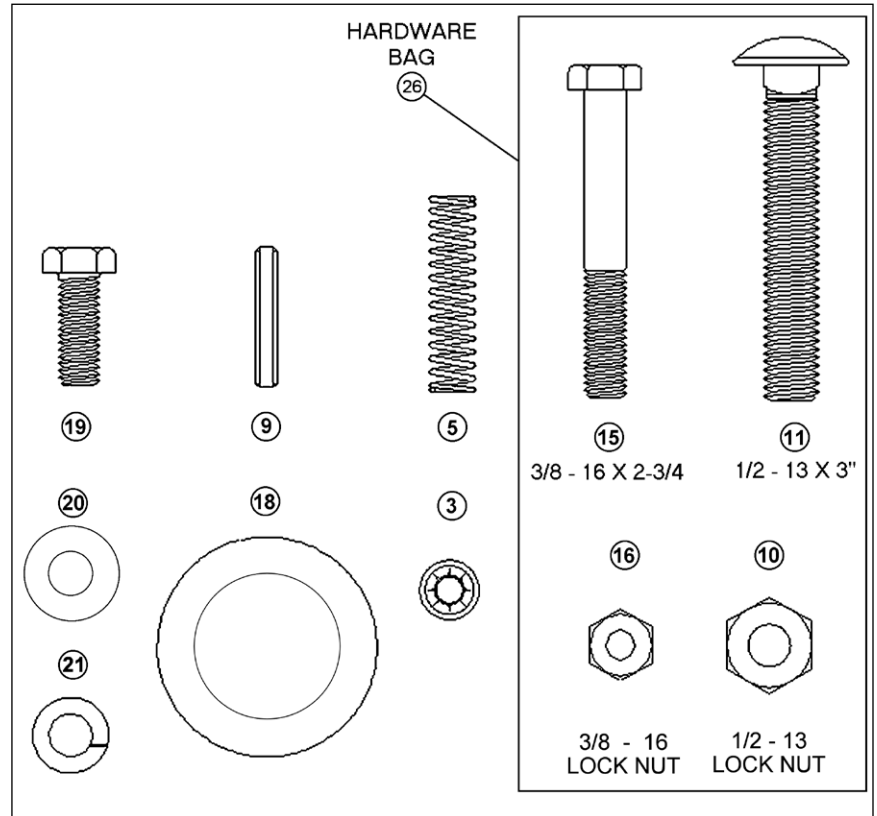

4. Locate the handle-hook assembly.
 - A. With the handle bar and release rods over the counterweight, and with the hook assembly side plates facing upward, place the square holes of the handle between the previously assembled stanchions.
 - B. Insert a 1/2-13 x 3" carriage bolt (item 11 from the hardware bag) from the inside through the square hole in the handle and on through the stanchion and ratchet.
 - C. Repeat for the other side.
 - D. Thread on 1/2-13 Lock nuts (item 10 from the hardware bag) and tighten. Once tightened, loosen a 1/2 turn to permit a hinging motion between the stanchion and the handle.
 - E. Repeat for other side.
5. Tighten all four 3/8-16 locknuts on bottom of stanchions.
6. Attach gas spring.
 - A. Remove tape from gas spring on handle
 - B. Pry the plastic retaining cap off bottom of gas spring with small screwdriver.
 - C. With the handle in the vertical position, pry bottom of gas spring onto ball bracket of the left stanchion.
 - D. Tap plastic retaining cap back onto gas spring.