

Size In.	ID In.	Rolled Edge (nom. in.)	Length	Weight Lbs	Galvanized Steel				304SS (or 316SS)		
					22ga	20ga	18ga	16ga	22ga	20ga	18ga
3	3.05	0.2	QF or Raw ends: Length = B X 2 + 9"	2.32	Std	Std	Std	Std	Std	Std	Std
4	3.86	0.2		3.00							
5	4.86	0.2		3.75							
6	5.89	0.2		4.25							
7	6.89	0.3		5.00							
8	7.88	0.3		6.00							
9	8.88	0.3		7.25							
10	9.89	0.3		8.50							
11	10.88	0.3		9.25							
12	11.97	0.4		10.75							
13	12.97	0.4		11.40							
14	13.96	0.4		13.50							
15	14.97	0.4	15.60								
16	15.97	0.4	17.56								
17	16.97	0.4	19.00								
18	17.96	0.4	21.00								
19	18.96	0.4	25.00								
20	19.96	0.4	30.00								
21	20.97	0.4	35.00								
22	21.97	0.4	39.50								
23	23.97	0.4	47.00								
24	24.93	0.4	53.50	Optional							
25	25.96	Angle Flange (AF)	Angle Flange or Flat Flange ends: Length = B X 2 + 15"	63.00	Std	Std	Std	Std	Std	Std	
26	25.96	AF		74.00							
27	27.94	AF		81.00							
28	27.94	AF		98.00							
29	28.89	AF		107.00							
30	29.89	AF		117.05							
31	30.94	AF		121.00							
32	31.87	AF		125.94							
33	32.92	AF		130.00							
34	33.95	AF		134.83							
35	34.90	AF		138.00							
36	35.93	AF		142.78							
37	36.99	AF		148.00							
38	37.86	AF		153.47							
39	38.88	AF		158.00							
40	39.97	AF		162.81							

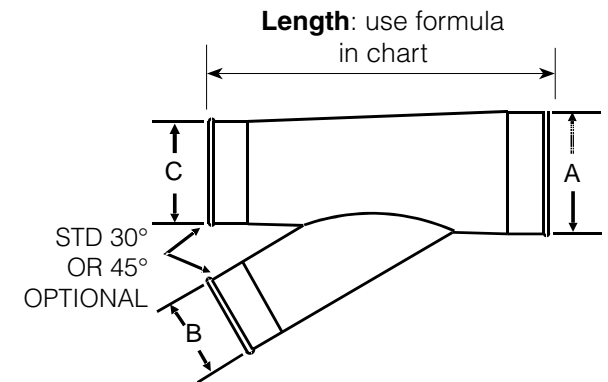

Temperature Rating of Product Components					
° F	QF Branch		Sealants		
1100°	Galvanized Steel	Optional - 304SS	3M Scotch Seal Metal Sealant 2084	Optional - Rock River Silicone Sealant	Optional - Red Devil HVAC/R High Temperature Silicone Sealant
500°					
400°					
390°					
250°					
194°					
0°					
-40°					
-60°					

Additional Notes
At temperatures ranging between 390° F and 480° F, the zinc-iron alloy layers in galvanized steel will continue to provide a high level of protection from corrosion. However, there may be some peeling, changes in mechanical properties, and reduction in the corrosion protection. Recommended max. service temperature is 390° F.
Rock River Silicone Sealant and Red Devil HVAC/R High Temperature Silicone Sealant are not paintable
304SS: bluing may occur at 800° F and above

Compliance / Rating of Product Components		
Product	Material	Compliance / Rating
QF Branch	Galvanized	ASTM A527 with a G-90 rating
	304SS	Finish meets ASTM A240
	316SS	Finish meets ASTM A240
3M Scotch Seal Metal Sealant 2084	Acetone blend	AAMA Specification 801.1
Rock River Sealant	100% Silicone	ASTM C920 Class 25, TT-S-00230C Class A and TT-S-001543A, FDA No 421 CFR 117.2600, conforms to FDA requirements
Red Devil HVAC/R High Temperature Sealant	Silicone	ASTM C920 Class 25, TT-S-00230C Class A and TT-S-001543A, CEBTP 432.6 140-2, Mil Spec 46106A, CGSB 19C9-9B, DIN 18540 Part 2, OREX 150031-2

**Construction:**

**Seam:** longitudinal seam is lapped, spot welded, and caulked.

**Collars:** located on the exterior side of each port and considered as air flow non-directional. Collars have a laser welded longitudinal seam. If air flow directional product is required, it must be stated on the PO and additional cost may be incurred. A raised lap seam and spot weld are used for attaching the collar to the body and no caulking is used. If caulking is required, additional cost may be incurred.

**Ends:** Standard QF end can be changed to Raw ID (RAWID), Raw OD (RAWOD), No Fitting (NF), Hose Adapter (RAWFLEX), Flat Flange (FFL), Angle Flange (ANGFL), or Van Stone (VANSTONE).