

# Raychem AMC-F5

## FIXED SET-POINT FREEZE-PROTECTION THERMOSTAT FOR NONHAZARDOUS LOCATIONS INSTALLATION INSTRUCTIONS

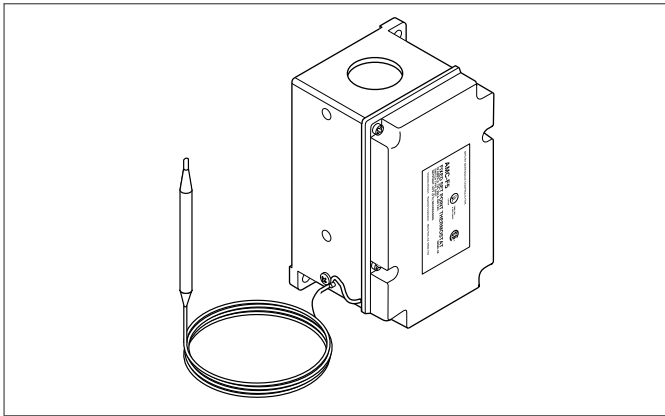

### DESCRIPTION

The AMC-F5 thermostat is designed for controlling freeze protection heat-tracing circuits in ordinary areas. The thermostat has a fixed nonadjustable set point of 40°F (4.4°C) and can be used in an ambient-sensing mode (with capillary coiled) or a line-sensing mode, or it can be used to control a contactor coil.

### ADDITIONAL MATERIALS REQUIRED

- Wire nuts, AT-180 aluminum tape (for line-sensing applications)

### APPROVALS



### SPECIFICATIONS

Enclosure	NEMA 4X, UV-resistant thermoplastics
Entries	One 3/4 in. through hole
Set point	40°F (4.4°C) nonadjustable
Sensor exposure limits	-30°F to 140°F (-34°C to 60°C)
Housing exposure limits	-30°F to 140°F (-34°C to 60°C)
Switch	SPST
Electrical rating	22 A at 125/250/480 Vac
Accuracy	±3°F (±1.7°C)
Deadband	2°F to 12°F (1.1°C to 6.7°C) above actuation temperature
Set point repeatability	±3°F (±1.7°C)
Sensor type	Fluid-filled (silicone) bulb and 2.5 ft (0.8 m) capillary
Sensor material	Tin-plated copper
Connection	Two 14 AWG (2 mm <sup>2</sup> ) pigtailed, one ground screw

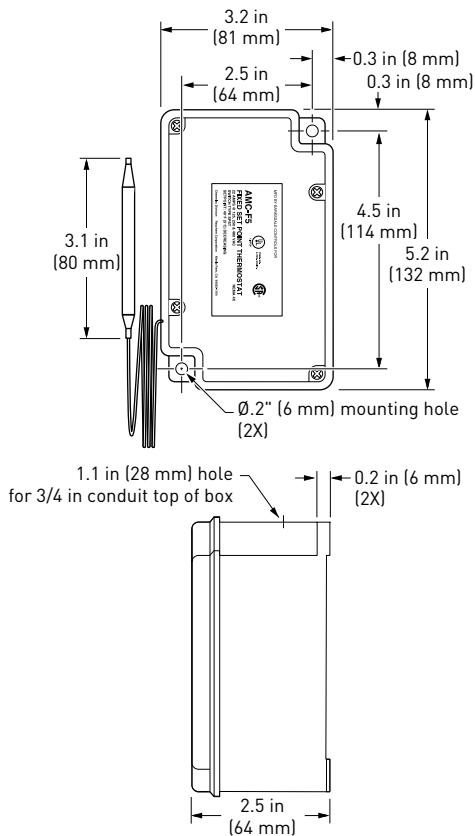

### WARNING:

This component is an electrical device. It must be installed correctly to ensure proper operation and to prevent shock or fire. Read these important warnings and carefully follow all the installation instructions.

Component approvals and performance are based on the use of specified parts only. Do not use substitute parts or vinyl electrical tape to make connections.

## INSTALLING THE THERMOSTAT

1. Verify that the thermostat is suitable for the area where it is to be installed.
2. Check the line voltage and the heat-tracing load to ensure that the thermostat ratings are not exceeded.
3. Mount the unit in a position that prevents condensation from draining into the enclosure from the connecting conduit, (see diagram above).

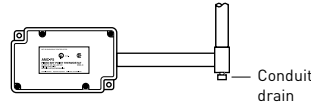

## POSITIONING (AMBIENT)

4. Mount ambient-sensing units in the area exposed to the coldest temperature and most wind. **Do not mount on the side of a warm building or in a location that is exposed to warm air currents or direct sunlight.**

## POSITIONING THE SENSOR BULB (LINE SENSING)

5. Position the bulb in the lower quadrant of the pipe as shown in the diagrams to the left. **Place the bulb at least three feet from**

**pipe supports, valves, or other heat sinks; protect the capillary from kinks or bends less than 1/2 inch in radius.**

6. Tape the bulb firmly to the pipe with AT-180 aluminum tape, making sure there is no air space between the bulb and pipe. **Do not overlap the bulb and heating cable with the same piece of AT-180 tape.**

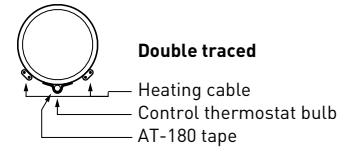
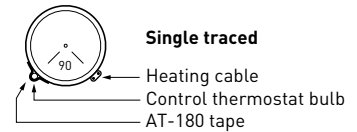

7. For metal-tank-wall sensing, use the BCK-35 bulb clamp (purchased separately from Raychem) and install the clamp per the instructions provided. Make sure there is no air space between the tank wall and the bulb.

For installation on plastic tanks, contact Pentair Industrial Heat Tracing Solutions at (800) 545-6258.

## WIRING

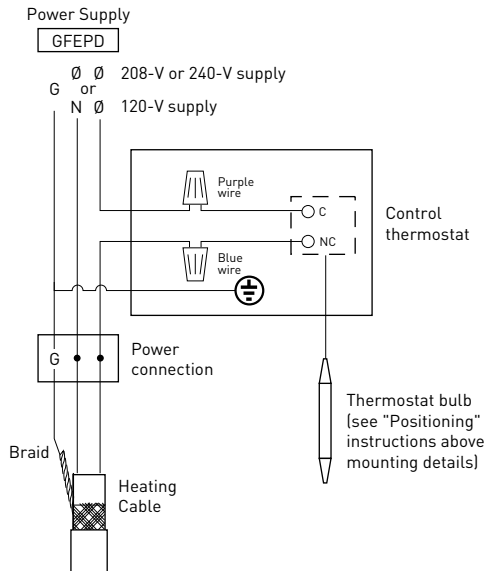

Figure 1. Heat-tracing control

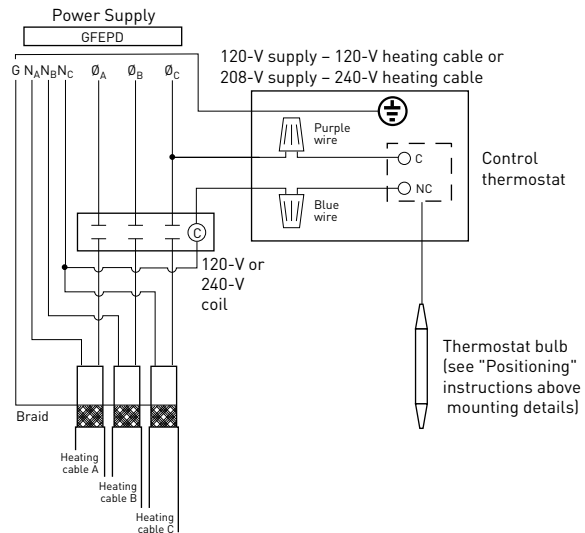

Figure 2. Contactor control

For switching heat-tracing loads greater than 22 A or switching multiple heat-tracing circuits.



WWW.PENTAIRTHERMAL.COM

### NORTH AMERICA

Tel: +1.800.545.6258  
 Fax: +1.800.527.5703  
 Tel: +1.650.216.1526  
 Fax: +1.650.474.7711  
 thermal.info@pentair.com

### EUROPE, MIDDLE EAST, AFRICA

Tel: +32.16.213.511  
 Fax: +32.16.213.603  
 thermal.info@pentair.com

### ASIA PACIFIC

Tel: +86.21.2412.1688  
 Fax: +86.21.5426.2937  
 cn.thermal.info@pentair.com

### LATIN AMERICA

Tel: +1.713.868.4800  
 Fax: +1.713.868.2333  
 thermal.info@pentair.com

Pentair and AMC are owned by Pentair or its global affiliates. All other trademarks are the property of their respective owners. Pentair reserves the right to change specifications without prior notice.