

EXTRUDED RUBBER BUMPER - M-2-18

APPROXIMATE WEIGHT IS: 1.06 lbs.

DURO METER READING OF 70 +/- 5
 TENSIL: 1850 PSI
 ELONGATION: 220%
 TEAR STRENGTH: 229 LBS
 IMPACT RESISTANCE: 75%

*** ANY ADDITIONS, DELETIONS, OR OMISSIONS
 THIS DRAWING AS THIS DRAWING WILL BE CON

ALL GRAPHICS PROVIDED ARE FOR REFERENCE ONLY. IF CERTAIN
 ARE CRITICAL PLEASE VERIFY THOSE DIMENSIONS WITH YOUR

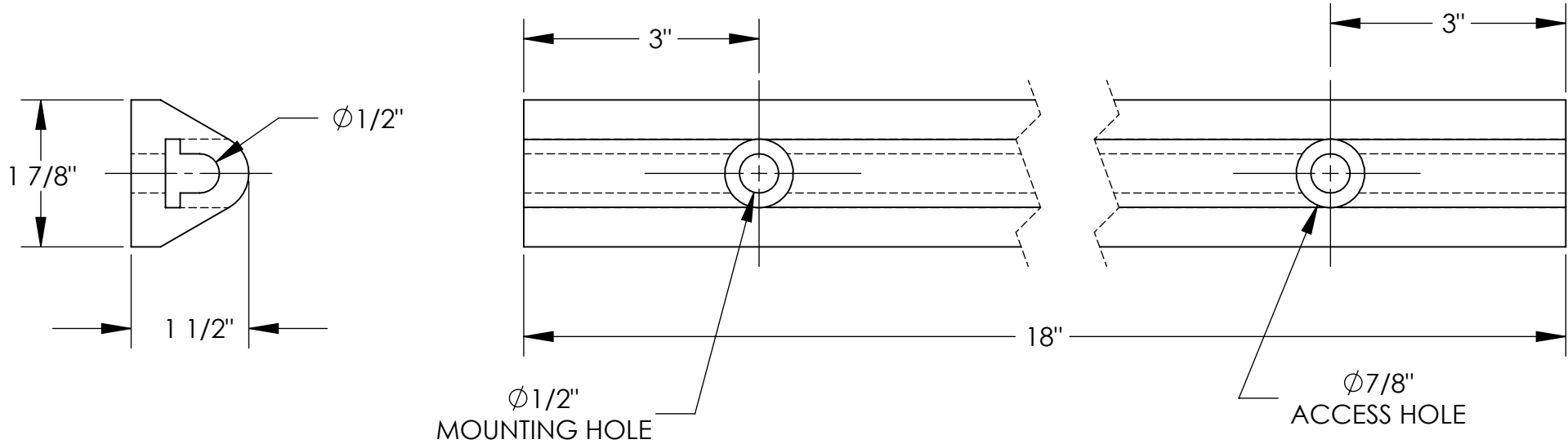

STANDARD FEATURES

MODEL NUMBER IS: M-2-18
 OVERALL WIDTH IS: $1\ 7/8"$
 OVERALL LENGTH IS: $18"$
 OVERALL PROJECTION IS: $1\ 1/2"$
 NUMBER OF MOUNTING HOLES: 2
 MOUNTING HOLE SIZE: $\phi 1/2"$
 ACCESS HOLE SIZE: $\phi 7/8"$

SPECIAL FEATURES

NONE

ALL SPECIAL UNITS
 ARE NON-RETURNABLE

I, the undersigned, hereby approve this print.
 This includes my approval of design & dimensions

As drawn As marked

Signed: _____ Date: _____

LEAD TIME WILL START UPON RECEIPT
 OF SIGNED APPROVAL DRAWING

DISTRIBUTOR'S NAME: VESTIL MANUFACTURING		P.O.# X
DRAWN BY: JDB	DATE: 8/7/08	W.O.# X
REFERENCE: X	QUOTE # X	SALES: X
		FILE NAME: 29-007-099
SCALE: 1:2		