

# EXTRUDED RUBBER BUMPER - M-2-24

APPROXIMATE WEIGHT IS: 1.42 lbs.

DURO METER READING OF 70 +/- 5  
 TENSIL: 1850 PSI  
 ELONGATION: 220%  
 TEAR STRENGTH: 229 LBS  
 IMPACT RESISTANCE: 75%

\*\*\* ANY ADDITIONS, DELETIONS, OR OMISSIONS  
 THIS DRAWING AS THIS DRAWING WILL BE CON

ALL GRAPHICS PROVIDED ARE FOR REFERENCE ONLY. IF CERTAIN  
 ARE CRITICAL PLEASE VERIFY THOSE DIMENSIONS WITH YOUR

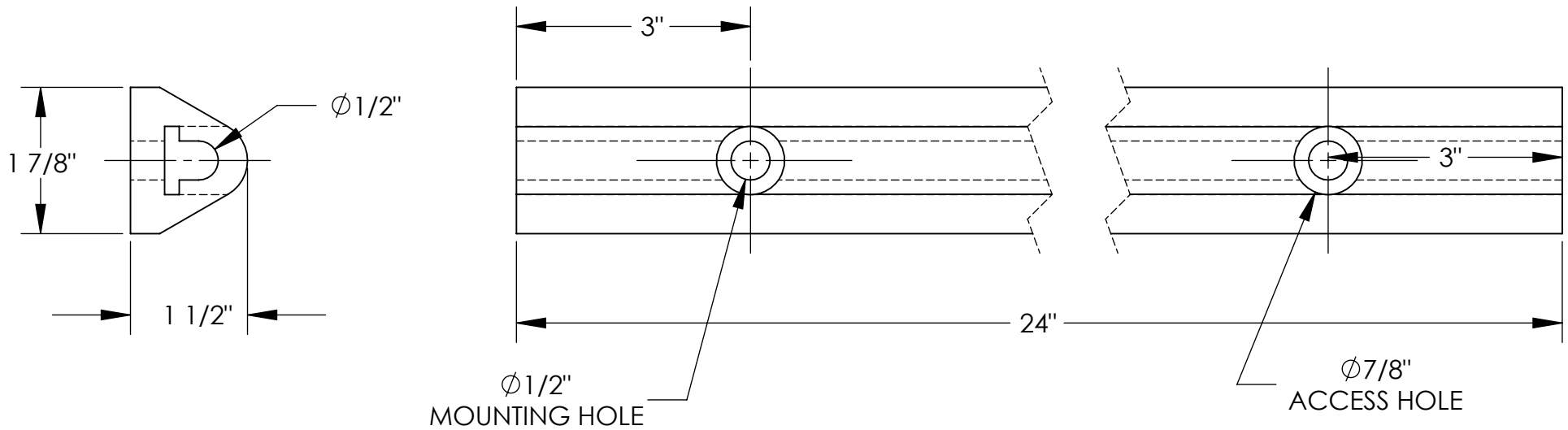

## STANDARD FEATURES

MODEL NUMBER IS: M-2-24  
 OVERALL WIDTH IS: 1 7/8"  
 OVERALL LENGTH IS: 24"  
 OVERALL PROJECTION IS: 1 1/2"  
 NUMBER OF MOUNTING HOLES: 2  
 MOUNTING HOLE SIZE:  $\phi 1/2"$   
 ACCESS HOLE SIZE:  $\phi 7/8"$

## SPECIAL FEATURES

NONE

ALL SPECIAL UNITS  
 ARE NON-RETURNABLE

A P P R O V A L	I, the undersigned, hereby approve this print. This includes my approval of design & dimensions	
	<input type="checkbox"/> As drawn	<input type="checkbox"/> As marked
	Signed: _____ Date: _____	
	LEAD TIME WILL START UPON RECEIPT OF SIGNED APPROVAL DRAWING	

DISTRIBUTOR'S NAME: <b>VESTIL MANUFACTURING</b>		P.O.# X
DRAWN BY: JDB	DATE: 8/7/08	SCALE: 1:2
REFERENCE: X	QUOTE # X	SALES: X
		FILE NAME: 29-007-100