

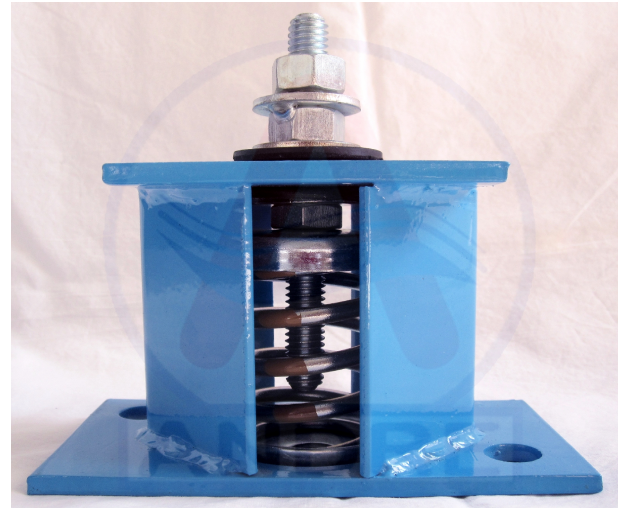

SEISMIC SPRING MOUNTS (Type "SS-A-100" Series 1" Deflection)

SS-A-100 Series Seismic Spring mounts are heavy duty steel spring isolators with built in all directional snubbing.

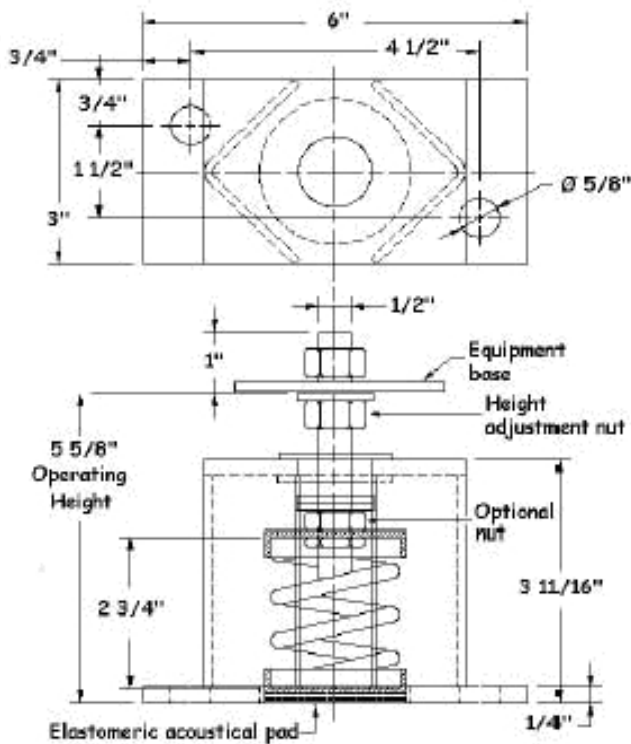

NOTES:

- Snubbing element: High quality neoprene
- Housing: Steel construction powder coated
- Spring: Hot Dip Galvanized
Large diameter
Color coded for easy field verification
High deflection, low natural frequency

FEATURES:

- Built-in leveling device
- Welded construction
- Mounting holes furnished as standard

INSTALLATION:

- Remove optional nut when using Spring # 106 and 107
- Housing will be elevated 1/4" above ground when installed, pull down to floor with anchor bolts

APPLICATION:

Used for air conditioning equipment such as compressors, air handling units, fans, pumps and chillers.

SS-A-100 ISOLATOR MODELS

ISOLATOR MODEL	RATED LOAD (LBS)	RATED DEFLECTION (INCH)	SPRING COLOR	
			MAIN	STRIPE
SS-A-101	60	1.3	SILVER	BLUE
SS-A-102	100	1.3	SILVER	ORANGE
SS-A-103	165	1.2	SILVER	BROWN
SS-A-104	260	1.0	SILVER	BLACK
SS-A-105	370	0.8	SILVER	YELLOW
SS-A-106	450	0.5	SILVER	RED
SS-A-107	700	0.45	SILVER	GREEN