

# #21701 JPM-1

Adjustable Printer Stand

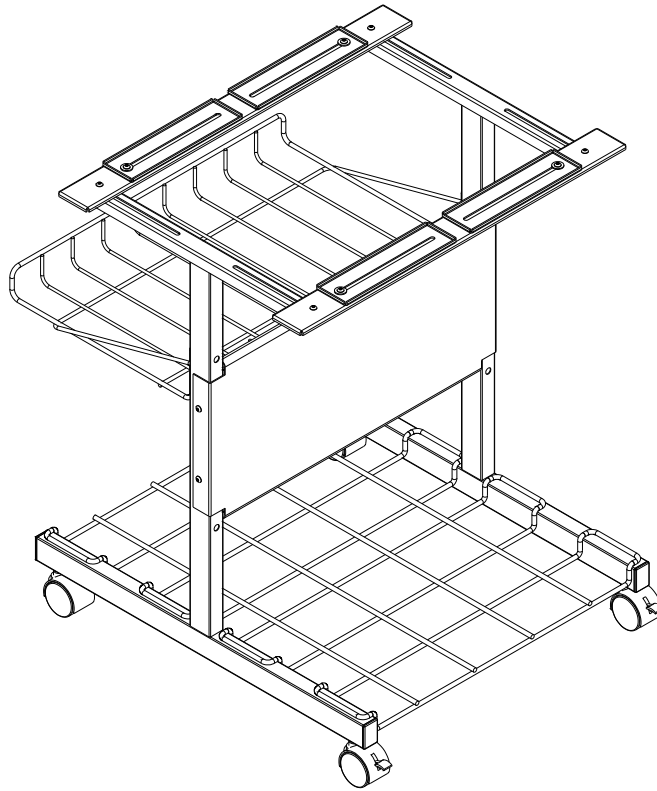

## Assembly Instructions

# Just Pure Magic Printer Stand JPM-1 #21701

Part	Drawing	Description	Qty	Part	Drawing	Description	Qty
P-1		Leg Frame	2 EA	<b>Hardware List</b>			
P-2		Back Stability Panel	1 EA	A		Flat Head Screw	4 EA
P-3		Long Metal Plates	2 EA	A1		Square Shoulder Screw	8 EA
P-4		Short Metal Plates	4 EA	B		Interior Threaded Post	4 EA
P-5		Forms Basket	1 EA	C		Leveling Feet	4 EA
P-6		Forms Rack	1 EA	D		2" Locking Casters (for Front)	2 EA
				E		2" Casters (for Back)	2 EA
				F		Allen Wrench	1 EA
				G		Caster Wrench	1 EA
				H		Cable Clips	4 EA
				J		Wing Nuts	8 EA
				K		Flat Washer	8 EA

**To Assemble:**

1. Identify and Separate all the Parts and Hardware.

2. Attach Back Stability Panel (P-2) to 2 Leg Frames (P-1) using 4 Flat head Screws (A) and 4 Interior Threaded Posts (B) as shown in illustration # 1.

*(Do not tighten the screws all the way)*

3. Attach 4 Leveling feet (C) or Casters to the Leg Frames [If casters, 2 Locking casters (D) in the front and 2 Casters (E) in the back. Tighten the Casters using Caster Wrench (G)]

**Illustration # 1**

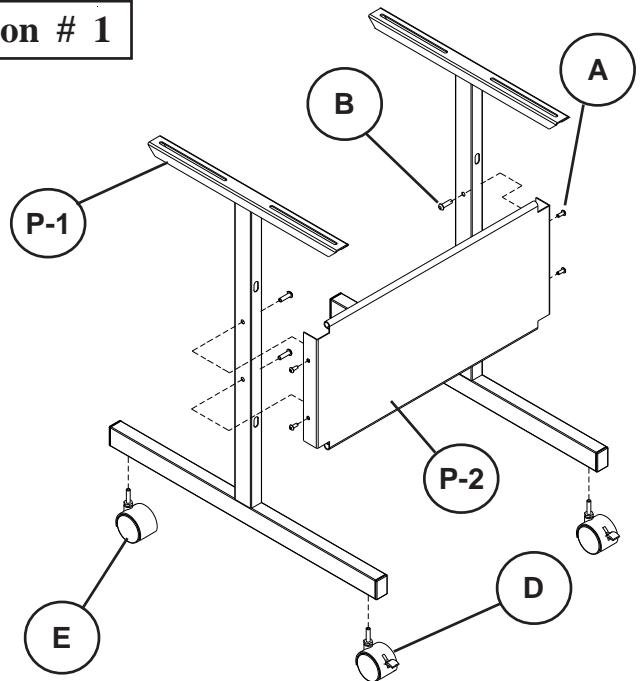

# #21701 JPM-1 Just Pure Magic Adjustable Printer Stand Assembly Diagram

Illustration # 2

4. Attach 2 Long Metal Plates (P-3) and 4 Short Metal plates (P-4) to the Leg Assembly (P-1) using 4 Square Shoulder Screws (A1), Flat Washers (K) and Wing Nuts (J).

See back page for different options. [Option #3 shown here.]

*Note: Long Metal Plates should be attached with Channel side down, and Short Metal Plates with the channel side up.*

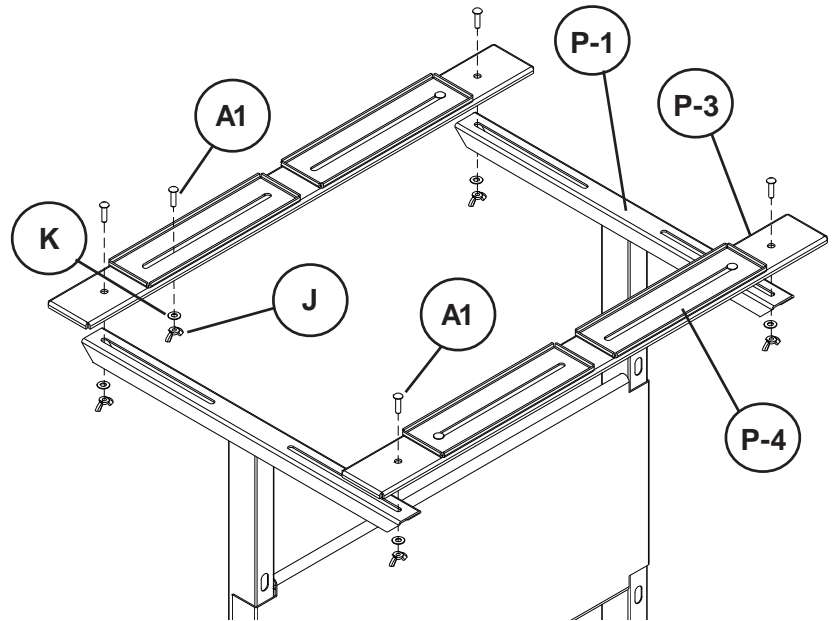
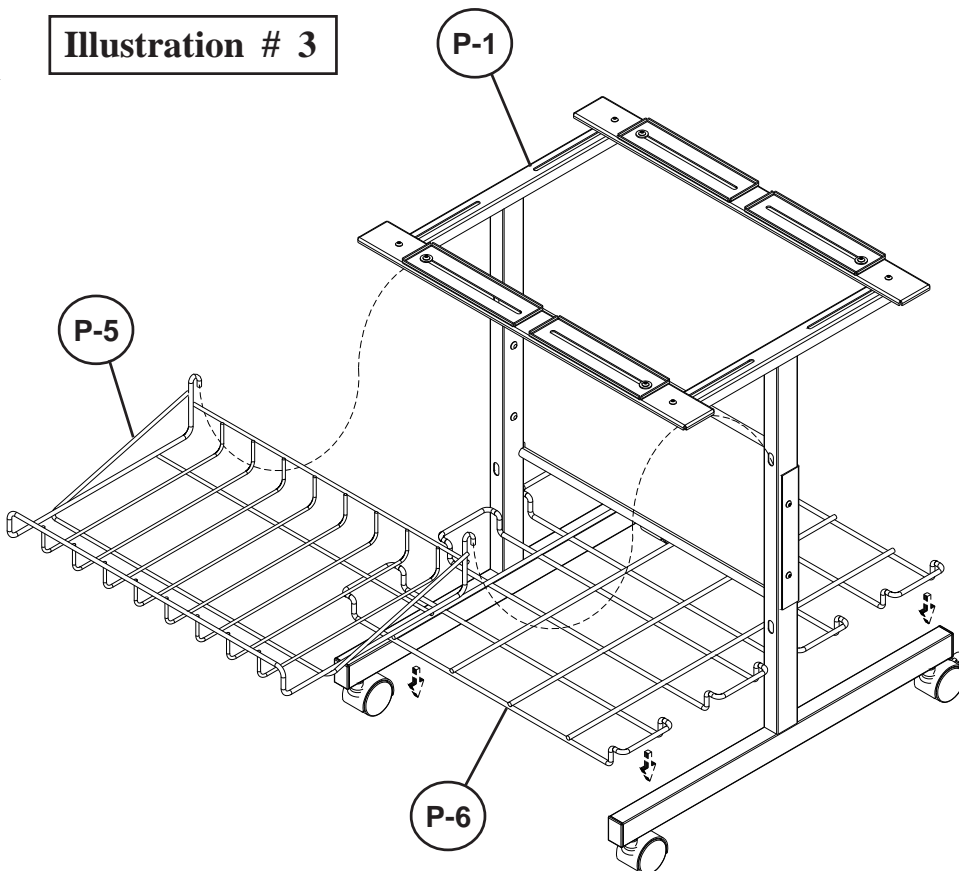

Illustration # 3



5. Install Forms Basket (P-5) in the holes on the Leg frame assy (P-1) as shown in illustration # 3.
6. Place Forms Rack (P-6) on lower part of Leg Frame Assembly (P-1).
7. Tighten all screws securely using the Allen Wrench (F).

### 1. FOR LARGE PRINTERS

Attach 2 Long Metal Plates (P-3) [through outer holes] and 4 Short Metal plates (P-4) to the Leg Frames using 4 Screws (A1), 4 Flat Washers (K) and 4 Wing Nuts (J).

Note: Long Metal Plates should be attached with Channel side down, and Short Metal Plates with the channel side up.

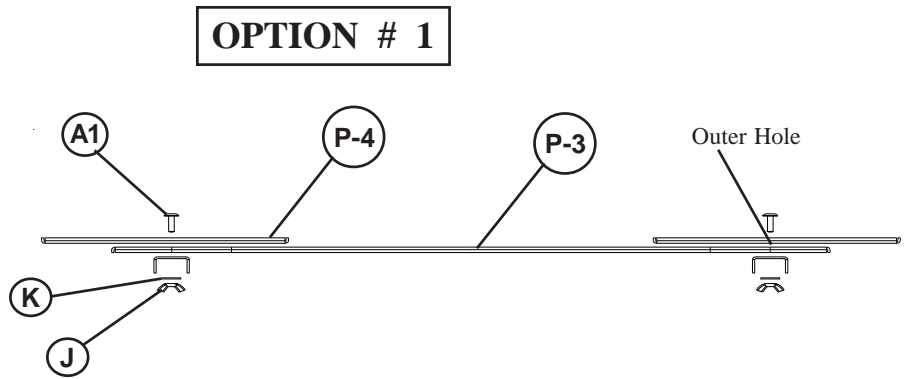

### OPTION # 2

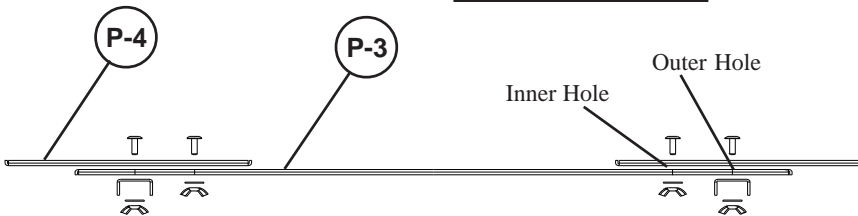

### 2. FOR EXTRA STABILITY WITH LARGE PRINTERS

Attach the Long Metal Plates (P-3) and Short Metal Plates (P-4) same as for the large Printers. Then attach Short Metal Plates through the inner holes on the Long Metal Plate using 4 Screws (A1), 4 Flat Washers (K) and 4 Wing Nuts (J) for added stability.

### 3. FOR NARROW PRINTERS

Attach 2 Long Metal Plates (P-3) [through outer holes] to the Leg Frames using 4 Screws (A1), 4 Flat Washers (K) and 4 Wing Nuts (J).

Then attach 4 Short Metal Plates (P-4) through the inner holes on the Long Metal Plate using 4 Screws (A1), 4 Flat Washers (K) and 4 Wing Nuts (J).

### OPTION # 3

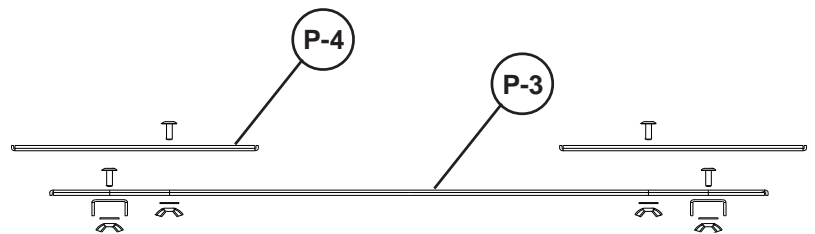

# #21701 JPM-1

## Adjustable Printer Stand

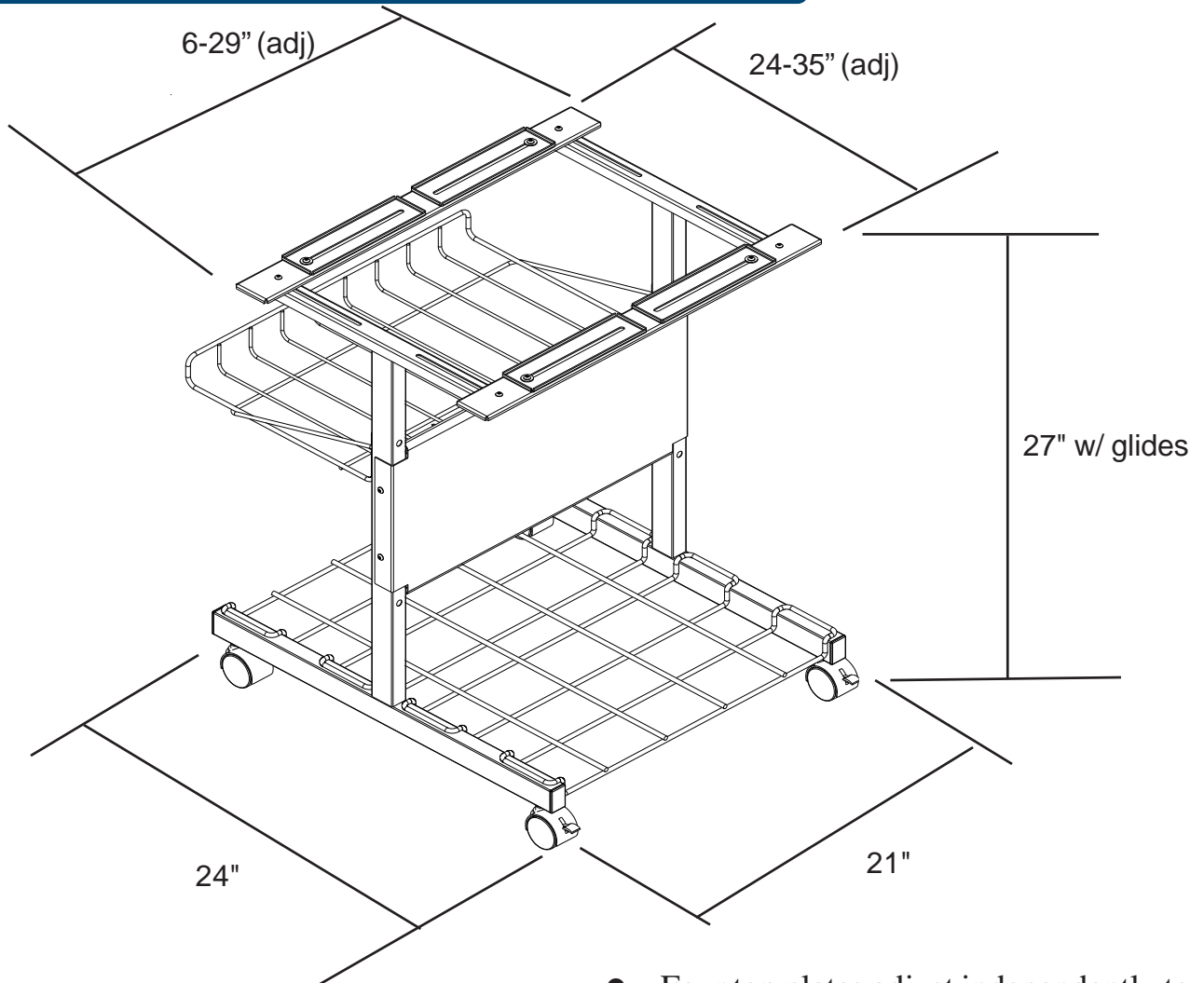

Shipping Information  
2.0 Cubic Feet  
24 lbs.

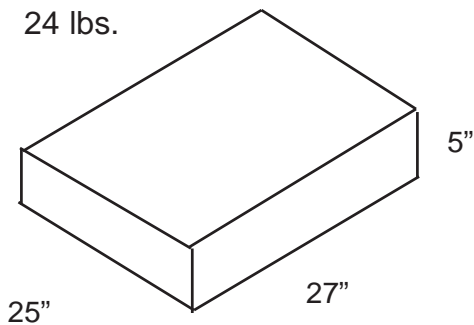

- Four top plates adjust independently to accommodate the smallest to largest printers.
- Standard with one-piece bottom forms rack and printout receiving basket. This can hold two full boxes of forms.
- 2" casters included.
- Ships UPS.