

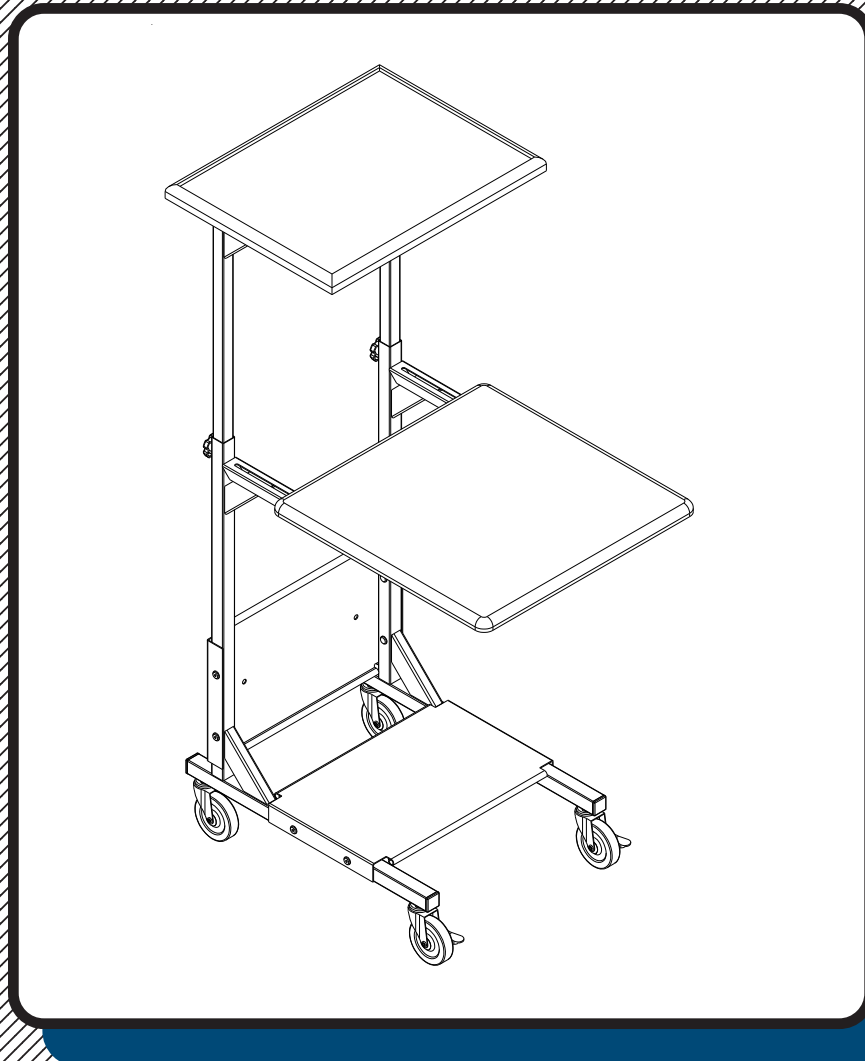

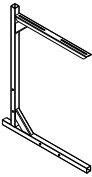

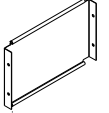





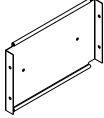

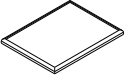
81052

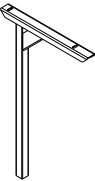
PBL AV Cart



Assembly Instructions

Part	Drawing	Description	Qty	Part	Drawing	Description	Qty
P-1		Leg Frame	2 EA	Hardware List			
P-2		Stability Panel	1 EA	A		Flat Head Screw-Short	8 EA
P-3		Stability Panel	1 EA	B		Interior Threaded Post	8 EA
P-4		Top Platform	1 EA	C		3" Locking Casters (for Front)	2 EA
P-5		Upper Insert	2 EA	D		3" Casters (for Back)	2 EA
P-6		Laptop Platform	1 EA	E		Allen Wrench	2 EA
				F		Caster Wrench	1 EA
				G		Knob	2 EA
				H		Flat Head Screw-Long	8 EA

To Assemble:

1. Identify and Separate all the Parts and Hardware.
2. Place the Top Platform (P-4) with the insert nuts facing up. Attach 2 Upper Inserts (P-5) using 4 Flat Head screws (A) as shown in illustration # 1.

(Do not tighten the screws all the way).

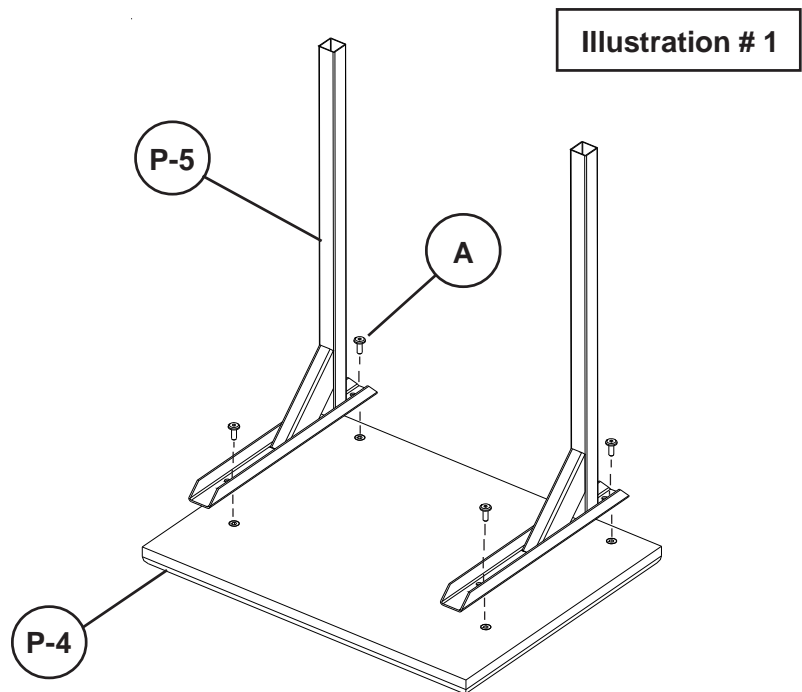

Assembly Diagram

Illustration # 2

3. Attach 1 Stability Panel (P-2) and 1 Stability Panel (P-3) to 2 Leg Frames (P-1) using 8 Flat Head screws (H) and 8 Interior Threaded Posts (B) as shown in illustration # 2.

4. Attach 2 Locking casters (C) in the front and 2 Casters (D) in the back. Tighten the Casters using Caster Wrench (F)]

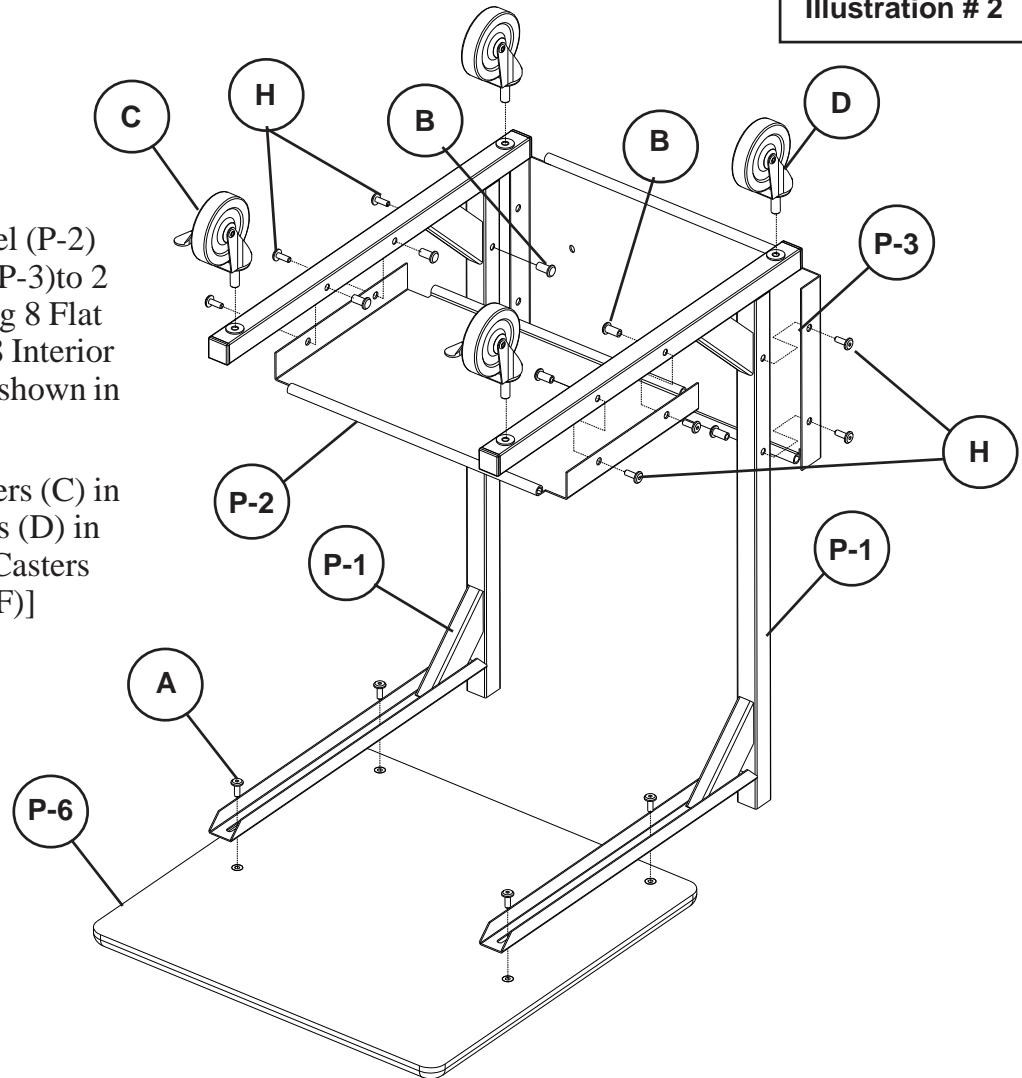

5. Attach Laptop Platform (P-6) to 2 Leg Frames (P-1) using 4 Flat Head screws (A).

- Slide the Top Assembly into the Leg Assembly and secure at desired height using 2 Knobs (G) as shown in illustration # 3.
- Tighten all screws securely using Allen Wrench (E).

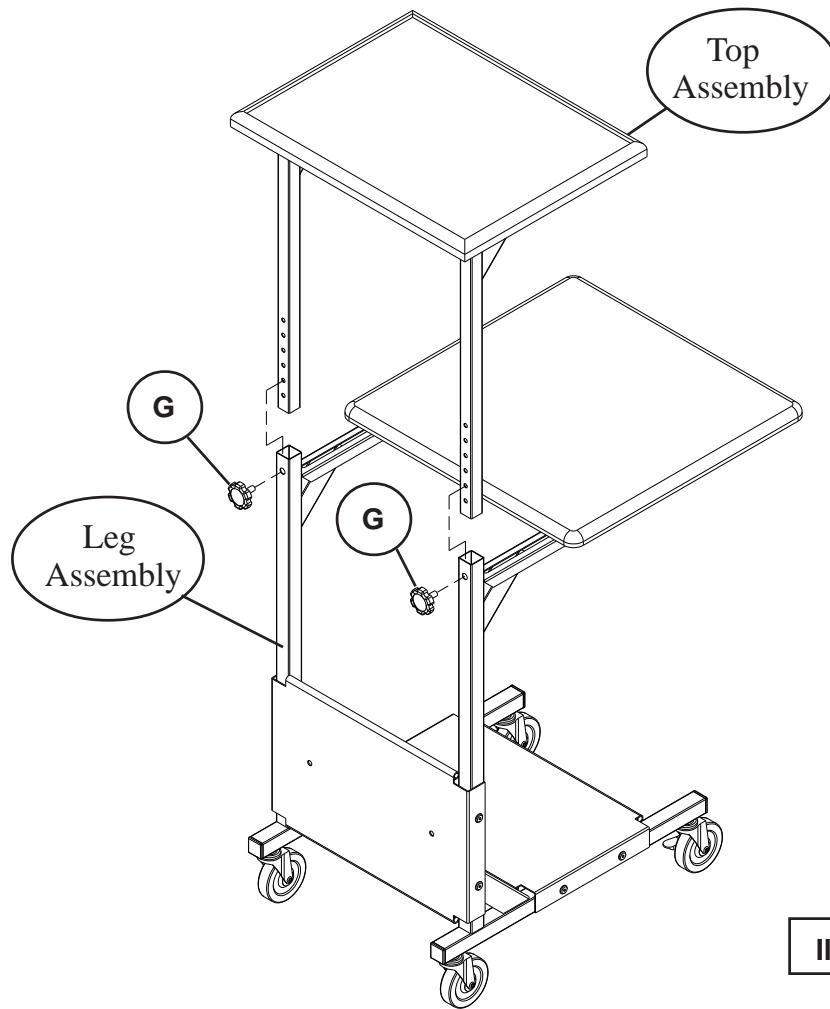

Illustration # 3