

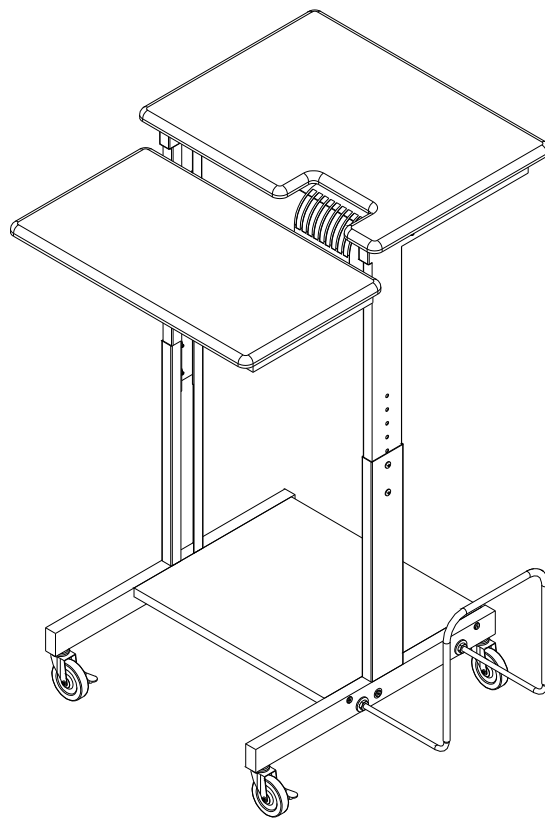

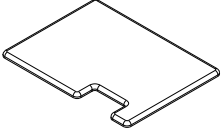

































# 85052 Web-AV

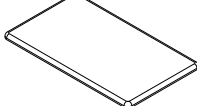
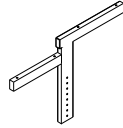
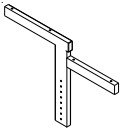
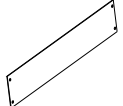

## Assembly Instructions

Part	Drawing	Description	Qty	Part	Drawing	Description	Qty																																												
P-1		Monitor Shelf	1 EA	<h3 style="margin: 0;">Hardware List</h3> <table style="width: 100%; border-collapse: collapse;"> <tr> <td style="width: 5%;">A</td> <td style="width: 10%;"></td> <td style="width: 75%;">9/16" Socket Screw</td> <td style="width: 10%;">12 EA</td> </tr> <tr> <td>A1</td> <td></td> <td>1-7/8" Socket Screw</td> <td>4 EA</td> </tr> <tr> <td>A2</td> <td></td> <td>2-1/2" Socket Screw</td> <td>8 EA</td> </tr> <tr> <td>C</td> <td></td> <td>Square Nut</td> <td>4 EA</td> </tr> <tr> <td>D</td> <td></td> <td>3" Locking Caster</td> <td>2 EA</td> </tr> <tr> <td>E</td> <td></td> <td>3" Caster</td> <td>2 EA</td> </tr> <tr> <td>F</td> <td></td> <td>Black Plastic Spacer</td> <td>2 EA</td> </tr> <tr> <td>G</td> <td></td> <td>Hex Nut</td> <td>4 EA</td> </tr> <tr> <td>H</td> <td></td> <td>Flat Washer</td> <td>4 EA</td> </tr> <tr> <td>J</td> <td></td> <td>Allen Wrench</td> <td>1 EA</td> </tr> <tr> <td>K</td> <td></td> <td>Open End Wrench</td> <td>1 EA</td> </tr> </table>				A		9/16" Socket Screw	12 EA	A1		1-7/8" Socket Screw	4 EA	A2		2-1/2" Socket Screw	8 EA	C		Square Nut	4 EA	D		3" Locking Caster	2 EA	E		3" Caster	2 EA	F		Black Plastic Spacer	2 EA	G		Hex Nut	4 EA	H		Flat Washer	4 EA	J		Allen Wrench	1 EA	K		Open End Wrench	1 EA
A		9/16" Socket Screw	12 EA																																																
A1		1-7/8" Socket Screw	4 EA																																																
A2		2-1/2" Socket Screw	8 EA																																																
C		Square Nut	4 EA																																																
D		3" Locking Caster	2 EA																																																
E		3" Caster	2 EA																																																
F		Black Plastic Spacer	2 EA																																																
G		Hex Nut	4 EA																																																
H		Flat Washer	4 EA																																																
J		Allen Wrench	1 EA																																																
K		Open End Wrench	1 EA																																																
P-2		Keyboard Shelf	1 EA																																																
P-3		Right Upper Insert	1 EA																																																
P-4		Left Upper Insert	1 EA																																																
P-5		Stability Panel	1 EA																																																
P-6		CD Rack	1 EA																																																
P-7		Accessory Shelf	1 EA																																																
P-8		Right Leg Receiver	1 EA																																																
P-9		Left Leg Receiver	1 EA																																																
P-10		CPU Sleeve	1 EA																																																
P-11		CPU Rod	2 EA																																																

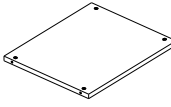
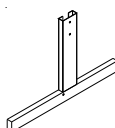
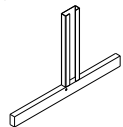
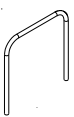
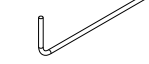
# Assembly Diagram

**READ THROUGH INSTRUCTIONS FROM BEGINNING TO END BEFORE STARTING TO ASSEMBLE UNIT.**

**Illustration # 1**

## To Assemble:

- 1.) Separate and Identify all the Parts and Hardware.
- 2.) Attach Monitor Shelf (P-1) to Right Upper Insert (P-3) and Left Upper Insert (P-4), using 4 each (A2) Socket Screws. Attach Keyboard Shelf (P-2) using 4 each (A2) Socket Screws as shown in illustration # 1.
- 3.) Attach CD Rack (P-6) using 4 each (A) screws. Attach as shown in illustration # 1.

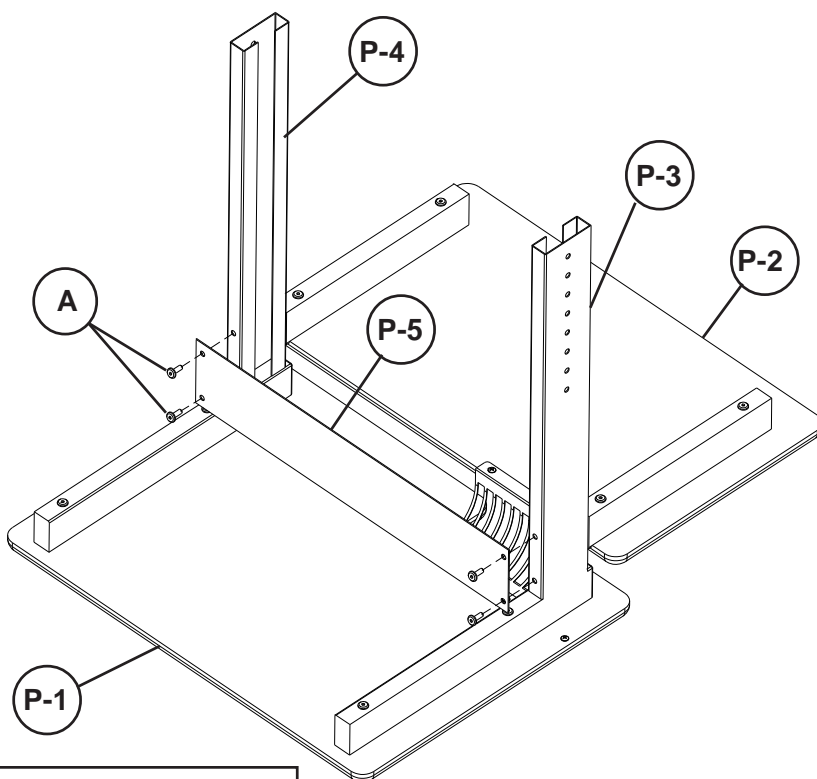
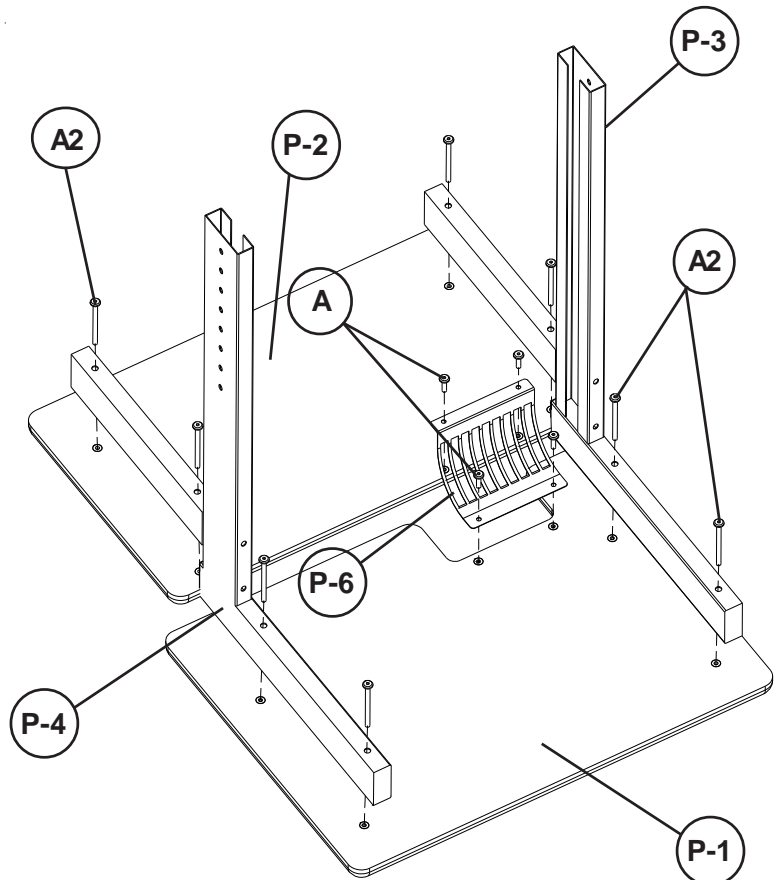

**Illustration # 2**

- 4.) Attach Stability Panel (P-5) to the Left upper insert and Right Upper Insert (P-4 & P-3) using 4 each (A) Screws as shown in illustration #2.

5.) Attach Right Leg Receiver (P-8) to Right Upper Insert (P-3) using 2 each (A) Screws and 2 each (C) Square nuts. Attach Left Leg Receiver (P-9) to Left Upper Insert (P-4) using 2 each (A) Screws and 2 each (C) Square nuts. (flat side of the nut should be next to the metal)

6.) Attach Accessory Shelf (P-7) to Left & Right Leg Receivers (P-9 & P-8) using 4 (A1) screws as shown in illustration # 3.

7.) Attach 2 each CPU Rods (P-11) to the Left Leg Receiver (P-9) (or Right Leg Receiver (P-8)). Secure each rod with 2 each (G) Hex nuts, 2 each (H) Flat Washers and 1 each (F) Black spacer. Slide CPU Sleeve (P-10) over ends of CPU Rods (P-12) as shown.

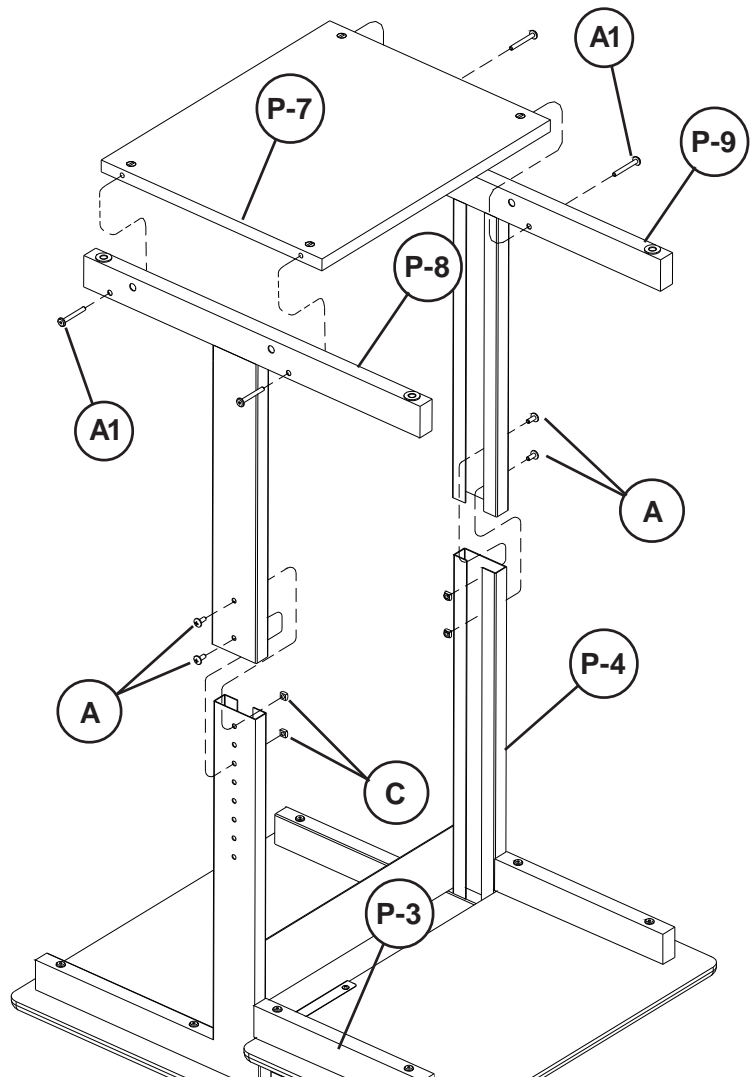
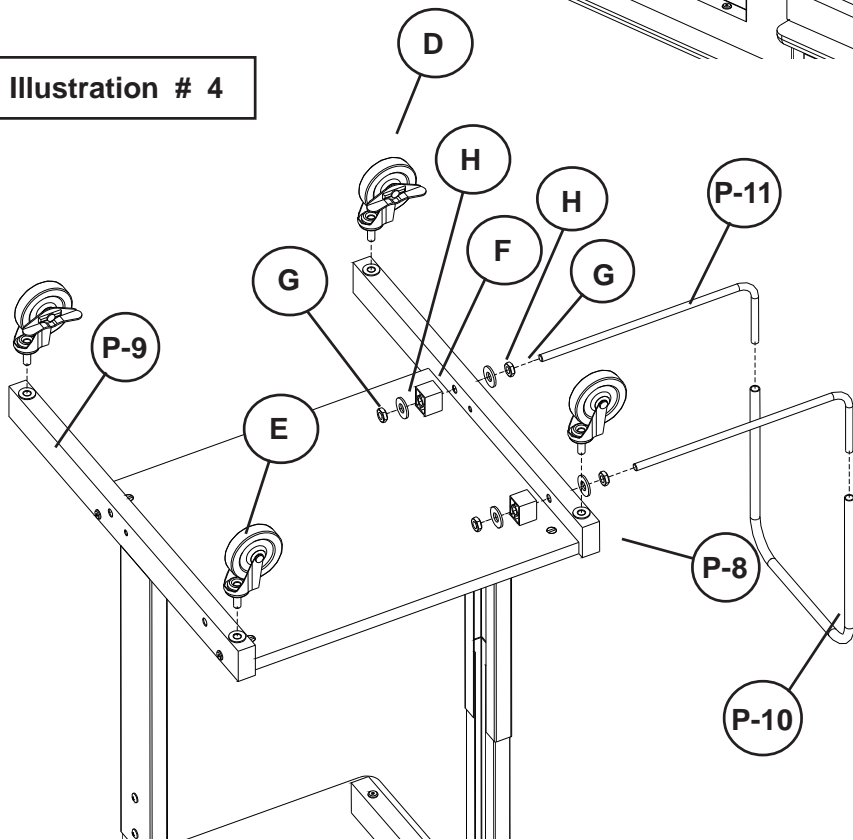

Illustration # 3

Illustration # 4



8.) Attach 2 each (D) Locking Casters to the front of the unit, and 2 each (E) Casters to the back of the unit as shown in illustration # 4. Tighten using Open End Wrench (K).

9.) Tighten all screws Securely using Allen Wrench (J).

# 85052 Web-AV

