

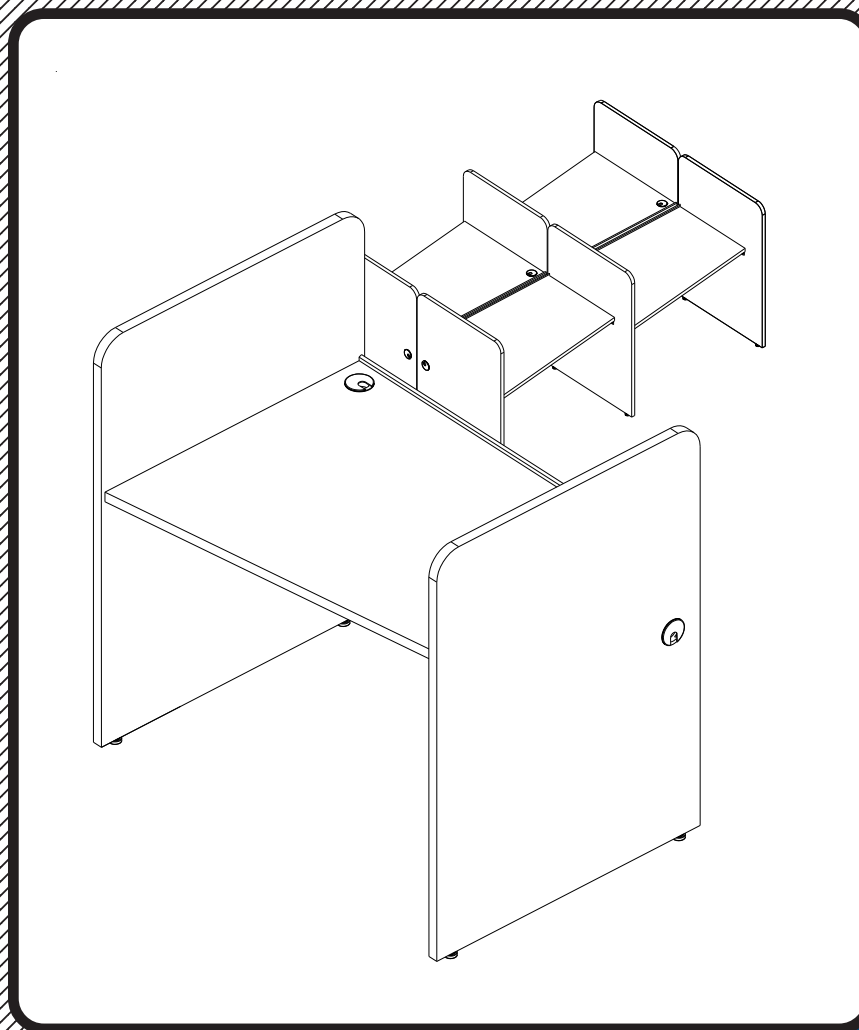







# #89891 H-Carrel

## Computer/Library Workcenter

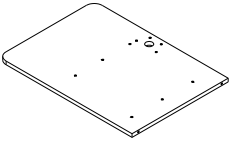

# Assembly Instructions

# #89891 H-Carrel

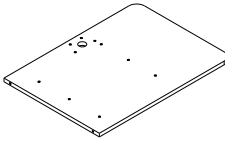
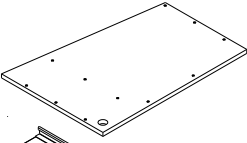
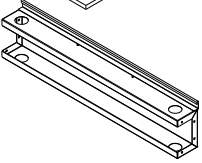
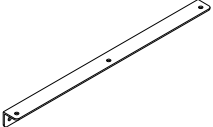
Part	Drawing	Description	Qty	Part	Drawing	Description	Qty
P1		Left Side Panel	1 EA	<div style="border: 2px solid black; padding: 10px;"> <p style="text-align: center;"><b>Hardware List</b></p> <p>A  Screw M6x15 22 EA</p> <p>B  Plastic Grommet Sleeve 3 EA</p> <p>C  Plastic Grommet Cap 3 EA</p> <p>D  Leveling Glide 4 EA</p> <p>E  Allen Wrench 1 EA</p> </div>			
P2		Right Side Panel	1 EA				
P3		Top Platform	1 EA				
P4		Welded cable Tray	1 EA				
P5		Angle Bracket	2 EA				
				<p><i>We recommend that you assemble this unit on a table.</i></p> <p>Tools required: Adjustable Crescent Wrench</p>			

### Missing Parts or UPS Damaged Parts

For Your Convenience you can  
EMAIL us at  
**[moorecoinc.com](mailto:moorecoinc.com)**  
24HOURS 7 DAYS A WEEK

***Should you require assistance during assembly,  
please call our Customer Service Department  
Monday - Friday 8 a.m. - 5 p.m.  
Central Standard Time 1-800-749-2258***

### NOTE:

**Two people are required  
to assemble this unit.**

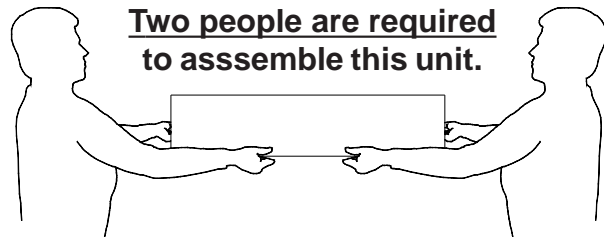

### Important Information

Do not use unless all screws are tight. At least every six months, check all screws to be sure they are tight. If parts are missing, broken, damaged, or worn, stop use of the product until repairs are made by your dealer using factory authorized parts.

READ THROUGH INSTRUCTIONS FROM BEGINNING TO END **BEFORE** STARTING TO ASSEMBLE UNIT.

Illustration # 1

- 1.) Identify and Separate all the Parts and Hardware.

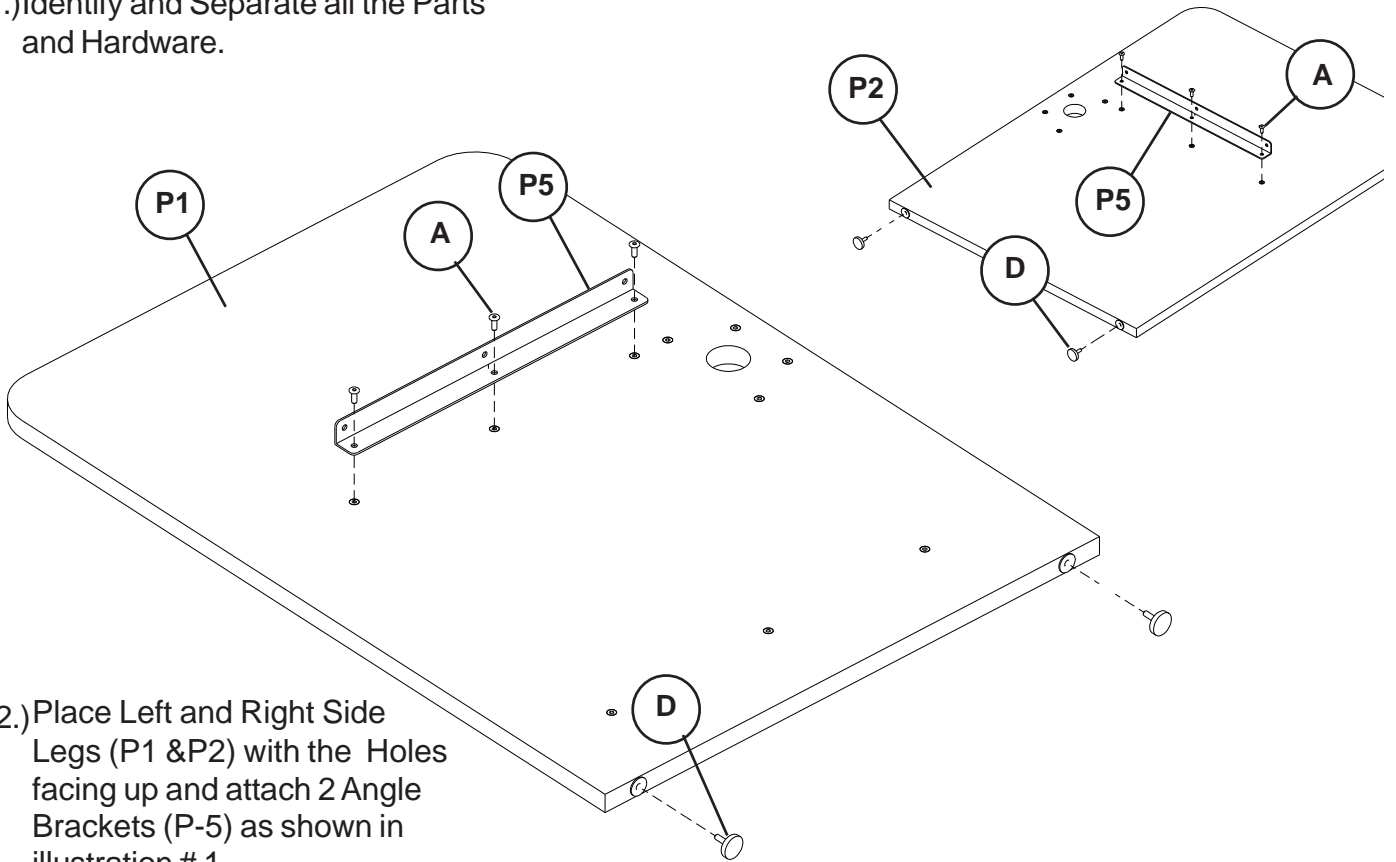

- 2.) Place Left and Right Side Legs (P1 & P2) with the Holes facing up and attach 2 Angle Brackets (P-5) as shown in illustration # 1.

- 3.) Attach 4 Leveling Feet (D).

Illustration # 2

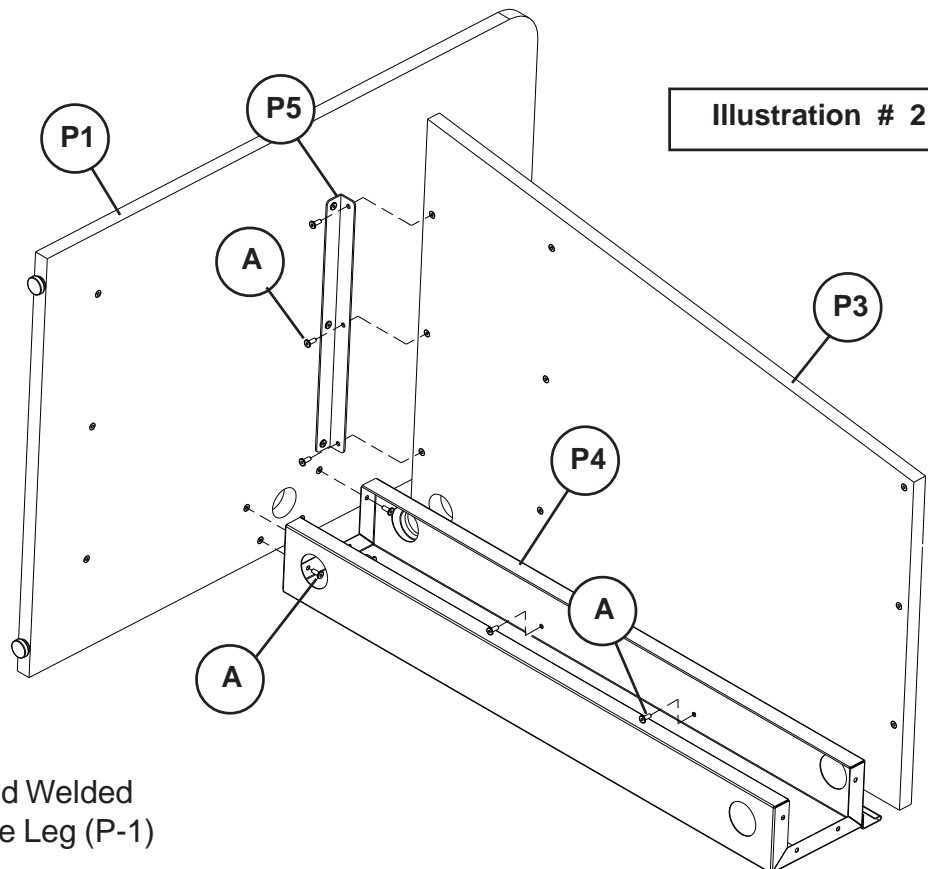

- 4.) Attach Top Platform (P3) and Welded Cable Tray (P-4) to Left Side Leg (P-1) as shown in illustration # 2.

5.) Attach Right Side Leg (P-2) to Top Platform (P3) and Welded Cable Tray (P-4) as shown in illustration #3 .

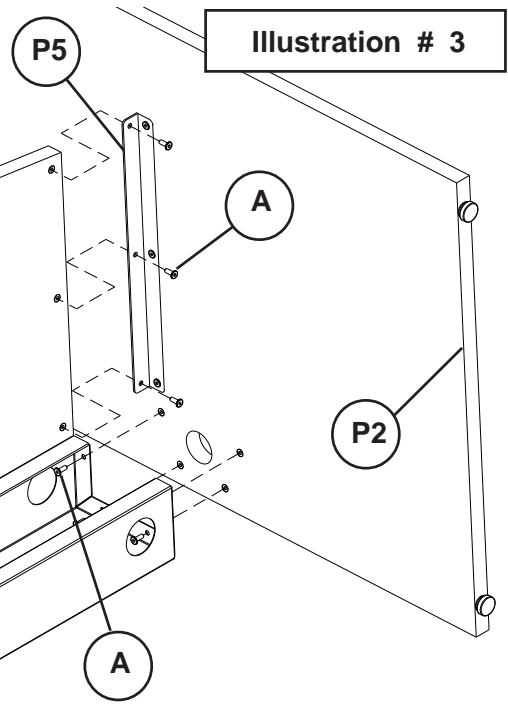

Illustration # 3

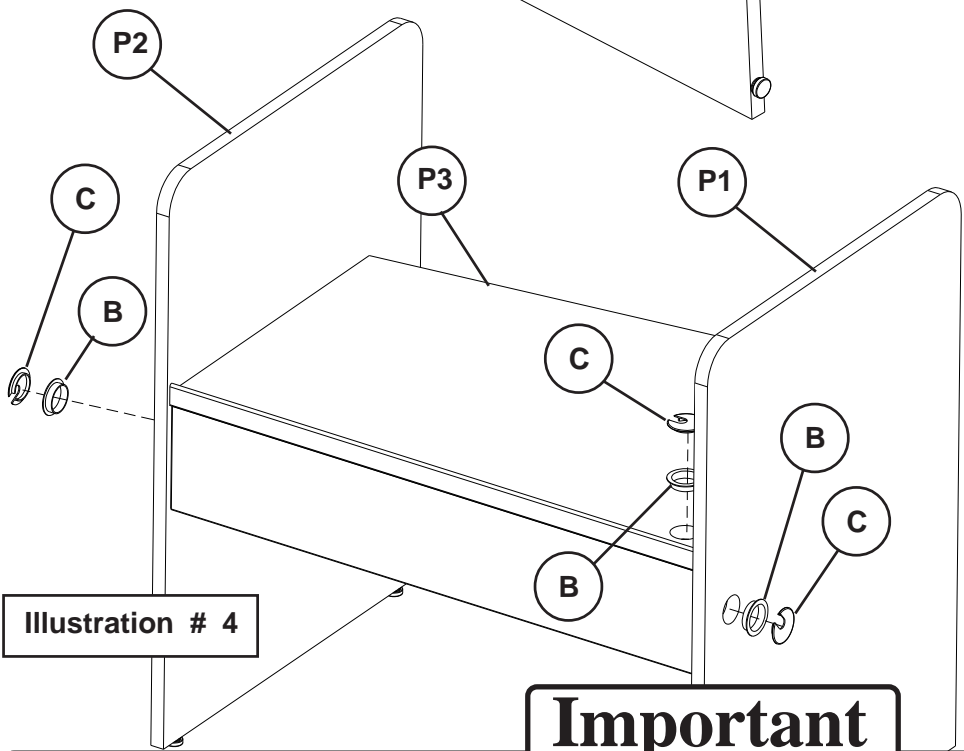

Illustration # 4

6.) Press Grommet Sleeves (B) in Round openings in Top Platform (P3), Left Side Leg (P-1), and Right Side Leg (P-2) as shown in illustration #4.

7.) Snap plastic Caps (C) into Grommet Sleeves (B) as shown in illustration #4.

## Important

The Balt product you have purchased is guaranteed against material and workmanship defects. This guarantee extends 1 year from date of purchase. Should this product fail to function satisfactorily under normal use due to defect or imperfection, the defective part or product will be replaced. Damage caused by common carriers during shipment is not included in this guarantee.

**This guarantee sets forth all applicable guarantees and remedies. No other warranty, expressed or implied shall apply. Failure to follow instructions found in Important Information Section of Owner Sheet shall void the guarantee. Consequential or incidental damages and or costs are not refundable.**