

Take A Stand™

90532

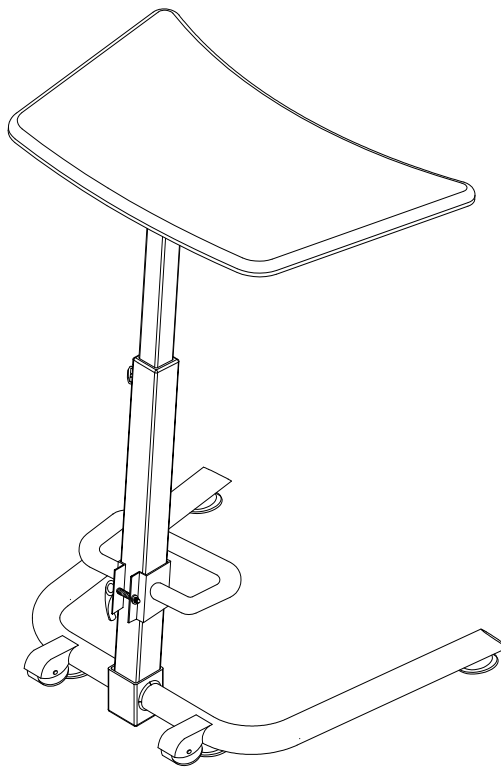







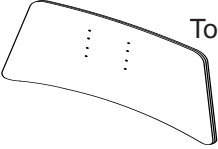

Up-Rite Student Height Adjustable Standing
Desk with Casters

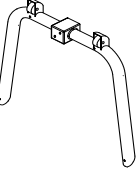

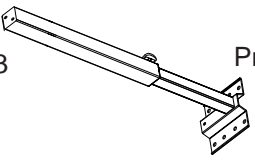
Assembly Instructions

Parts List

Hardware List

Part	Drawing	Description	Qty	Drawing	Description	Qty
P-1		Top Panel	1 EA	A	 Screw M6*18mm	8 EA
P-2		Base	1 EA	B	 Screw M8*25mm	2 EA
P-3		Pneumatic Post	1 EA	C	 Glide	4 EA
P-4		Footrest	1 EA	D	 Lock Washer	2 EA
				E	 Allen Wrench	1 EA
				F	 Glide Wrench	1 EA
				G	 Tension Plates	2 EA

Assembly Diagram

- 1.) Identify and separate all the Parts and Hardware.
- 2.) Screw in four Glides (C) into the holes in the bottom of the Base (P2) as shown in illustration #1. Tighten Glides using Glide Wrench (F).

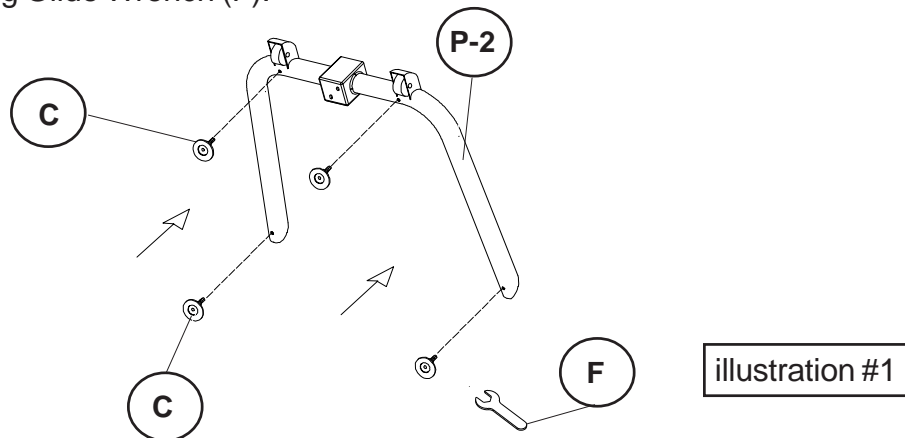

- 3.) See NOTE at bottom of page first. Open the clamp on the Footrest (P4) and insert the two Tension Plates (G) as shown in illustration #2. Slide the Footrest up the Pneumatic Post (P3) from the bottom. Close the clamp on the Footrest to lock it in place.

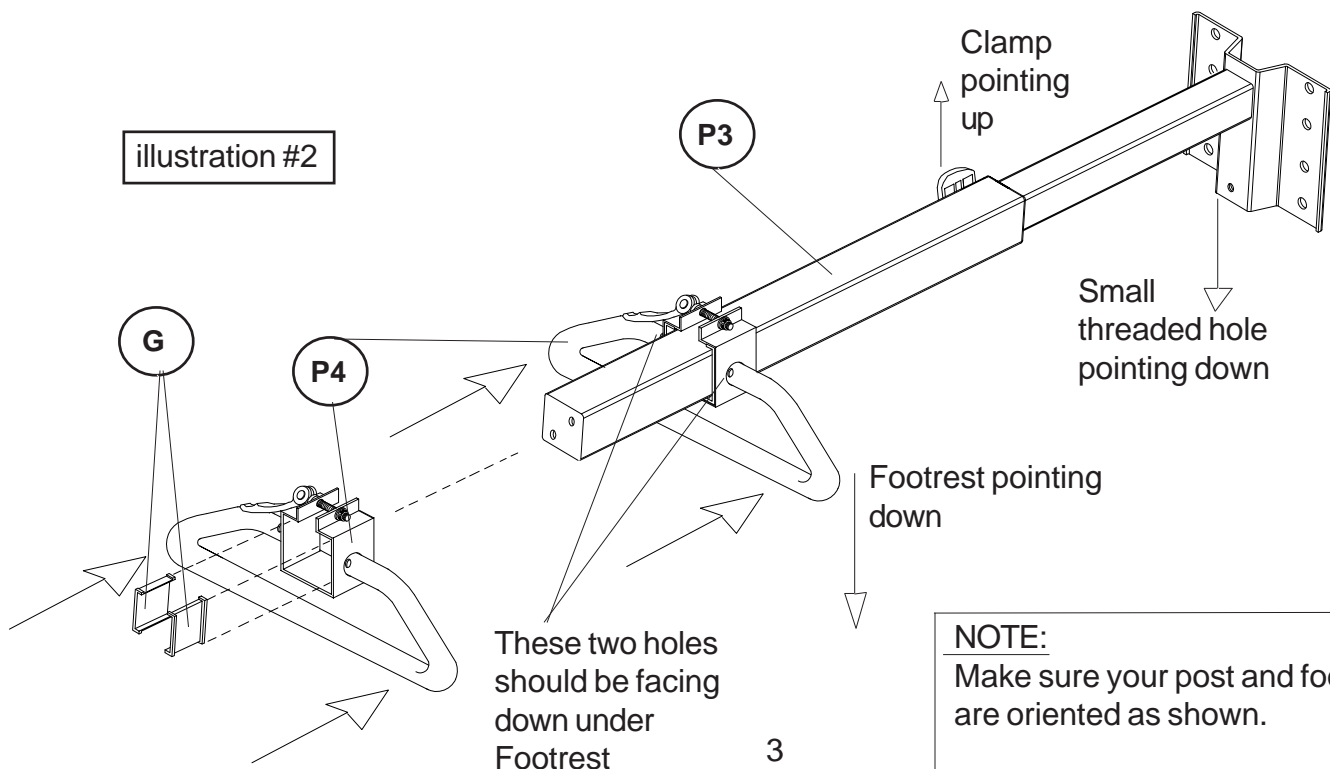

4.) Insert the Pneumatic Post (P3) into the Base (P2) as shown in illustration #3. Secure into place using two Screws (B) with a Lock Washer (D) on each and tighten with Allen Wrench (E).

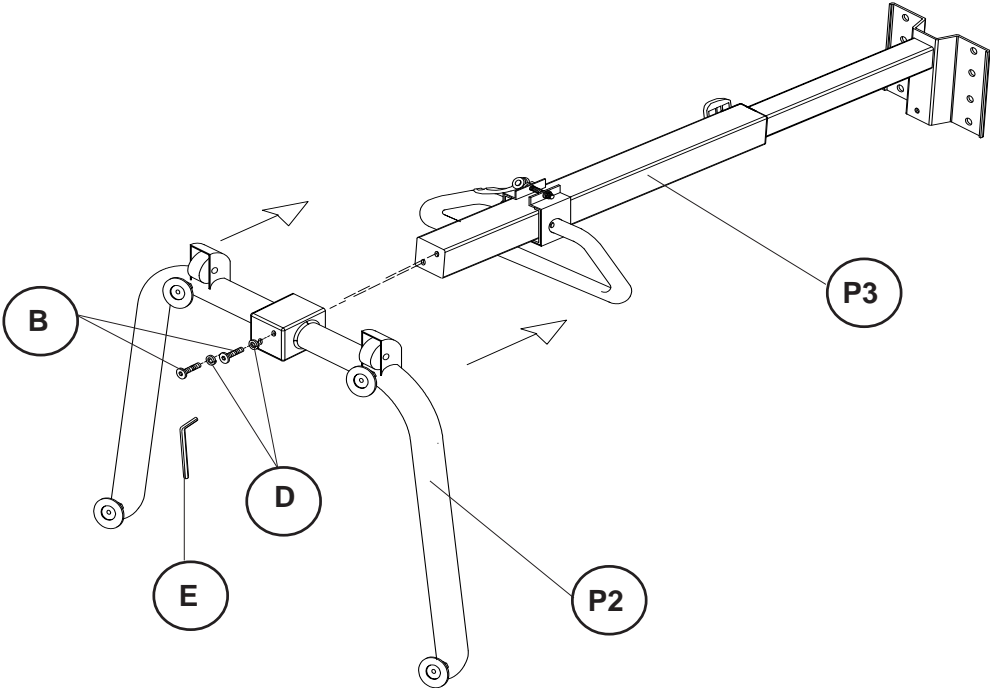

illustration #3

5.) Line up the threaded inserts in the bottom of the Top Panel (P1) with the holes in the top plate of the Pneumatic Post. Attach the the two using eight Screws (A) and tighten with Allen Wrench (E) as shown in illustration #4.

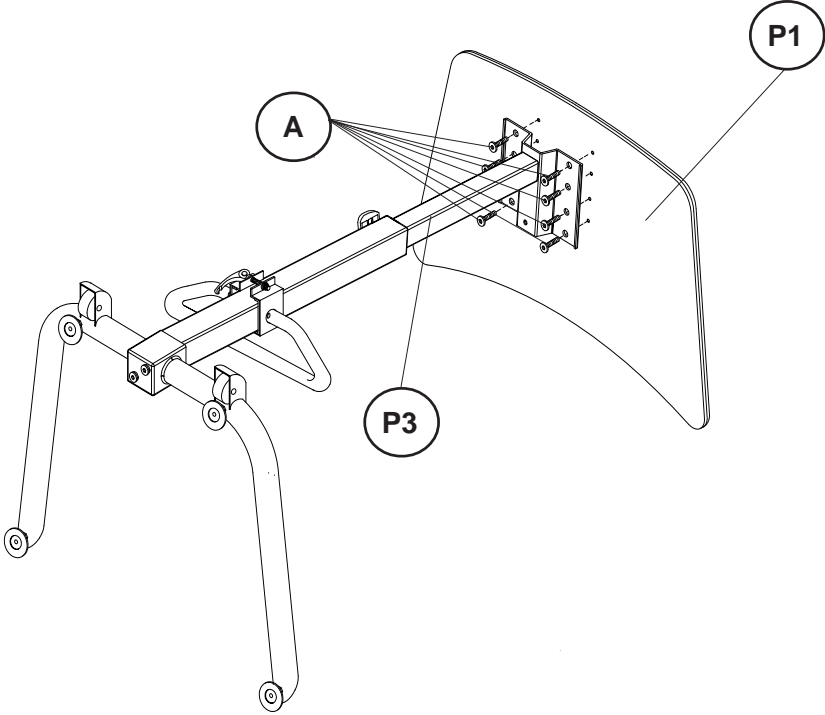

illustration #4

Take A Stand™ 90532

Up-Rite Student Height Adjustable Standing Desk with Casters

