

8 7 6 5 4 3 2 1

Rev	Description	Date	Approval
PB	Bl Baseline	08/09/16	A.F

The **Blickman CCC4-17** Space-Saver Case Cart are designed to give added capacity by utilizing the cube while minimizing the floor space required by larger carts

Material: Body - 18 gauge, Door(s) - 18 gauge, Top - 16 gauge, Bolster Chann. - 16 gauge, Bumper channel - 14 gauge

Construction: One Doors w/ Hasp paddle Latch, Two SS Wire Shelf, Four Swivel Casters, One Push Handle, One Card Holder 8.5"x11", Full Perimeter Bumper, One Door Stop.

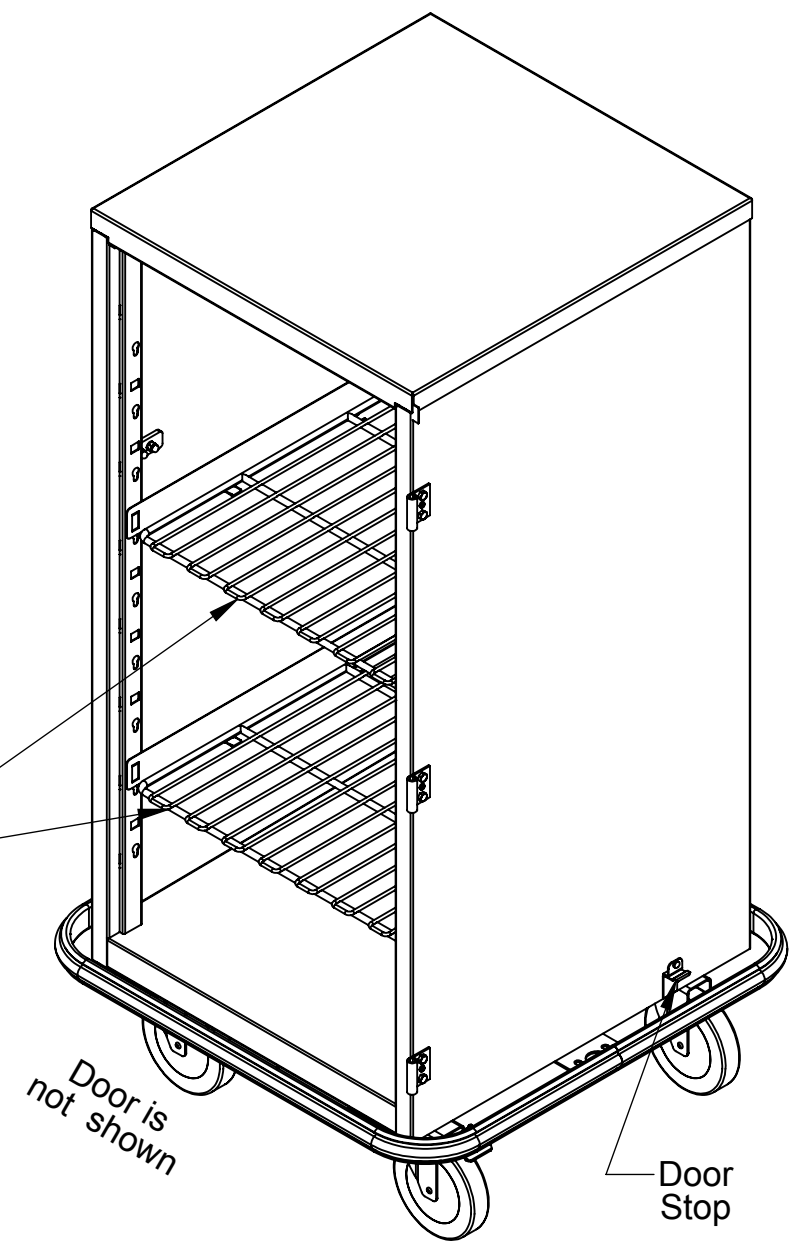
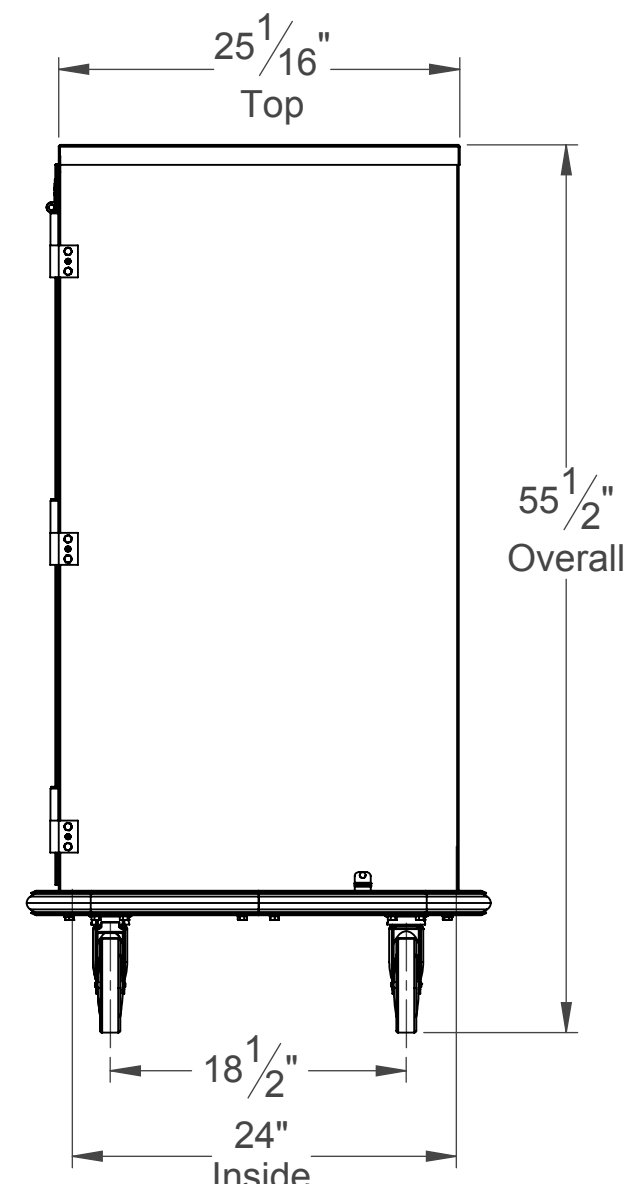
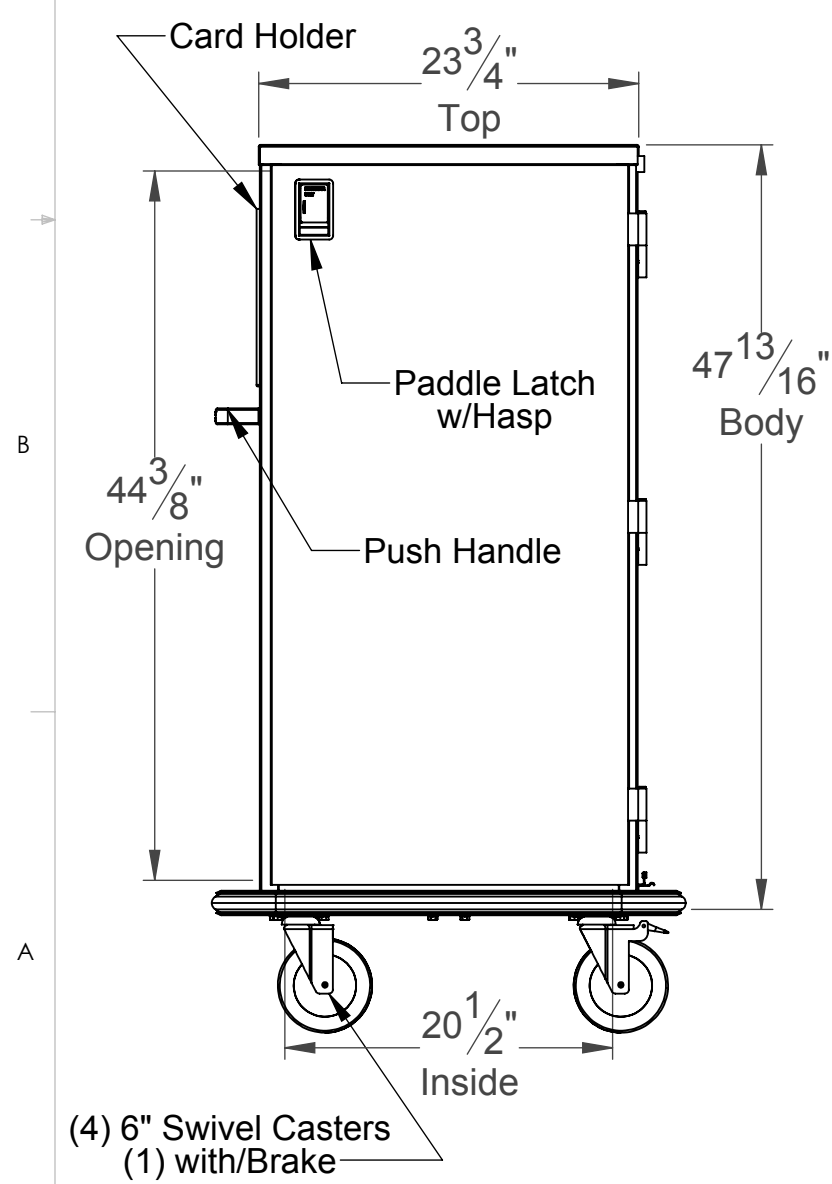
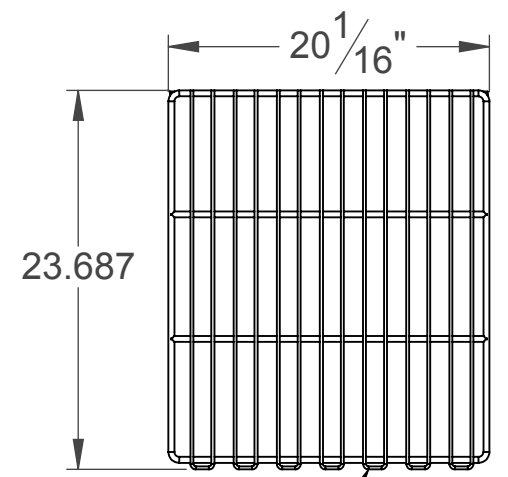
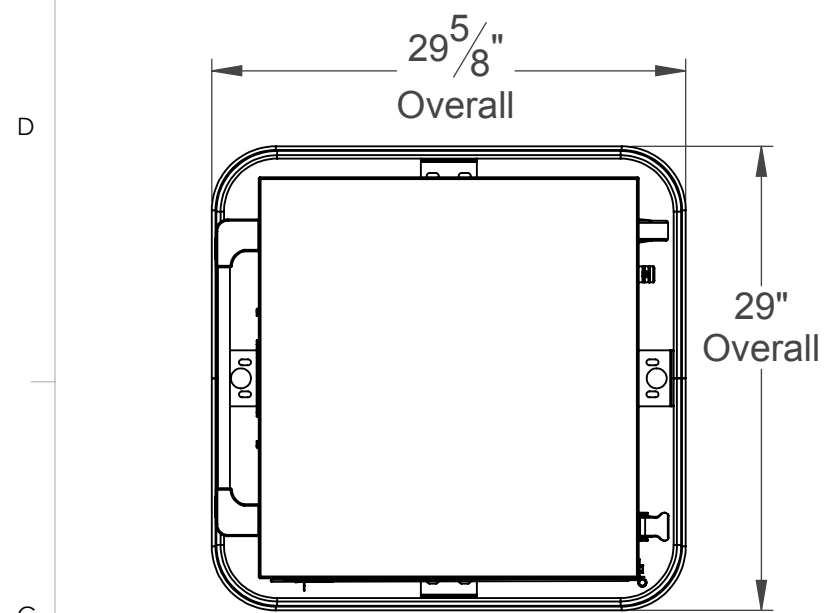

H:\SW\Closed Case Cart\Design2015\

PO#: _____ DATE: _____

APPROVAL: _____

TITLE: _____



	NAME	DATE
DRAWN	M.J	08/09/2016
ENG APPR.	A.F	06/16/2017
MATERIAL	N/A	
FINISH	N/A	
APPRX WEIGHT =	180.859 lbs	

BLICKMAN INC. CLIFTON, N.J.		
TITLE: CCC4-17, CASE CART		
SIZE B	PART NO. 2273334000	REV PB

PROPRIETARY AND CONFIDENTIAL
THE INFORMATION CONTAINED IN THIS DRAWING IS THE SOLE PROPERTY OF BLICKMAN HEALTH INDUSTRIES. ANY REPRODUCTION IN PART OR AS A WHOLE WITHOUT THE WRITTEN PERMISSION OF BLICKMAN HEALTH INDUSTRIES IS PROHIBITED.

UNLESS OTHERWISE SPECIFIED:
DIMENSIONS ARE IN INCHES
BEND RADIUS = MTL. THK.
TOLERANCES:
FRACTION: ±1/8"
DECIMAL: ±.125"

8 7 6 5 4 3 2 1