

- Exceeds American National Standard Z358.1 Specifications
- Galvanized Steel Protected with BradTect® Safety Yellow Coating or All Stainless Steel (S19-310SS)
- Combination Units may be Top-Supplied or Mid-Supplied
- Universal Identification Sign and Inspection Tag Included
- Full, One-Year Warranty
- Classified by Underwriters Laboratory Inc. to ANSI Z358.1
- SpinTec™ showerheads are covered by one or more of the following patents: 8113446; D594,089; D669,555; Reg. Comm. Des. D001079560-0001. Other patents pending.

### Specifications

Combination Drench Shower/Eyewash saves space and fits easily into any work environment. Shower valve operates quickly by a pull rod with a triangular handle. Shower provides a superior washdown with a more even spray pattern. Eyewash operated by a large, highly visible push handle. Safe, steady water flow under varying water supply conditions from 30–90 PSI is assured by integral flow control in the sprayhead assembly. NOTE: The ANSI Z358.1 standard requires an uninterrupted supply of flushing fluid at a minimum 30 PSI flowing pressure.

This plumbing fixture is not intended to dispense water for human consumption through drinking or for preparation of food or beverages.

### Standard Equipment

#### SpinTec™ Showerhead

High performance corrosion-resistant stainless steel showerhead measures 1½" (38mm) in diameter. SpinTec drench showerhead features integral 22 GPM flow control, conserving water and helping to accurately size your tepid water system.

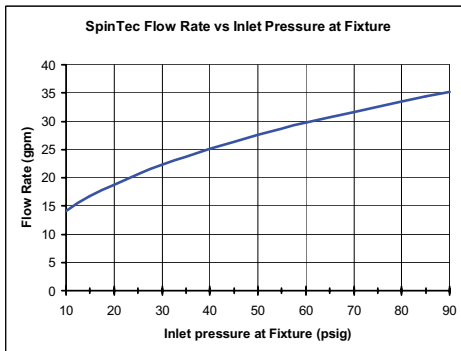

#### Shower Valve

Chrome-plated brass 1" NPT stay-open ball valve. Operated by a stainless steel pull rod with triangular handle. S19-310SS is all stainless steel.

#### Eyewash Bowl

10¾" (273mm) diameter corrosion-resistant stainless steel.

#### Standard Sprayhead Assembly

Chrome-plated brass sprayhead with twin soft-flow eyewash heads and protective sprayhead covers. Safe, steady water flow under varying water supply conditions from 30–90 PSI is assured by integral flow control in the sprayhead assembly. S19-310SS is all stainless steel.

#### Eyewash Valve

S19-310SS has all-stainless steel ½" NPT stay-open ball valve hand operated by a stainless steel push handle.

#### Face Spray Ring

Chrome-plated circular spray ring provides supplemental face spray. Flow control assures adequate flow from eyewash nozzles and face spray ring from 30–90 PSI.

#### Pipe and Fittings

S19-310SS is all stainless steel.

#### Water Supply

1¼" NPT.

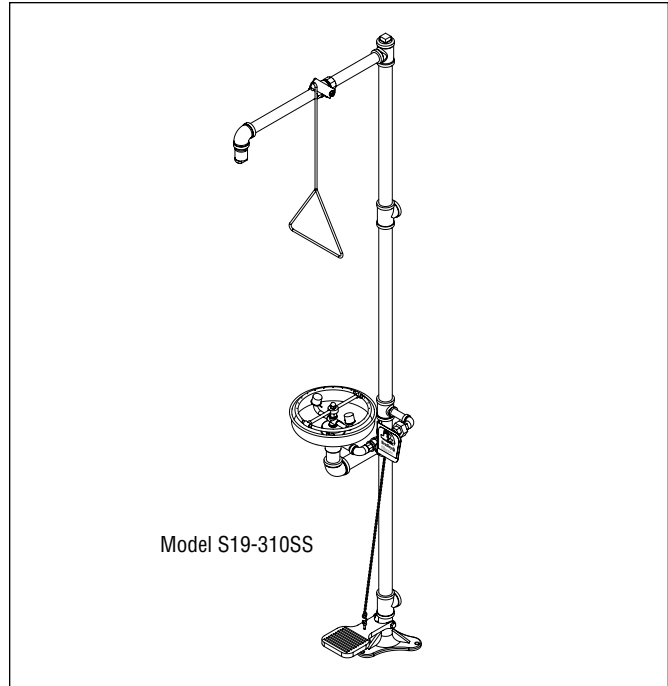

Local codes may require the installation of a backflow prevention valve to complete proper installation. Compliance with local codes is the responsibility of the installer. Valve must be tested annually to verify that it is functioning properly. Backflow prevention valves are not included with the fixture and may be supplied by the contractor or purchased from Bradley Corporation.

Model	Description
<input type="checkbox"/> S19-310SS	Drench Shower and Eye/Face Wash - <b>All Stainless Steel</b>
<input type="checkbox"/> S19-2200	Navigator EFX60 - Emergency Thermostatic Mixing Valve



**Recommended Option:**

Navigator S19-2200 EFX60  
Emergency Thermostatic Mixing Valve

**NAVIGATOR**

Satisfies ANSI Z358.1  
tepid water requirements.

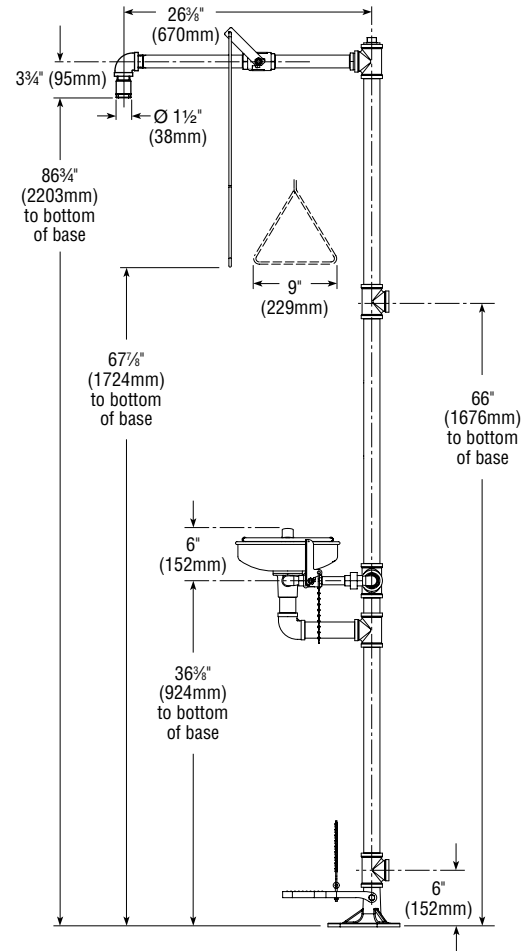

Top View  
 From Bowl

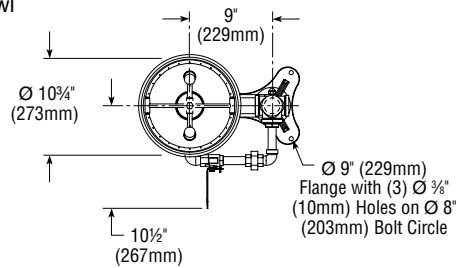

All dimensions assume standard thread engagement. Variations in manufacturing allow for +/- 1/8" (3mm) per threaded joint. To find the tolerance of a dimension, add the number of thread joints in between a dimension and multiply it by 1/8" (3mm).