

A684 RAZOR-X WITH HOLD DOWNS

INSTRUCTIONS

1. FASTEN THE BASE TO A TABLE USING THE 4 HOLES IN THE BASE.
2. SLIDE THE RAZOR-X HEAD TO ONE SIDE OF THE ALUMINUM TRACK.
3. FEED MATERIAL UNDER 1 TO 3 HOLD DOWNS.
4. FEED MATERIAL OVER THE TOP OF THE ALUMINUM TRACK TO YOUR DESIRED LENGTH.
5. SLIDE RAZOR-X HEAD TO OTHER SIDE TO CUT MATERIAL.

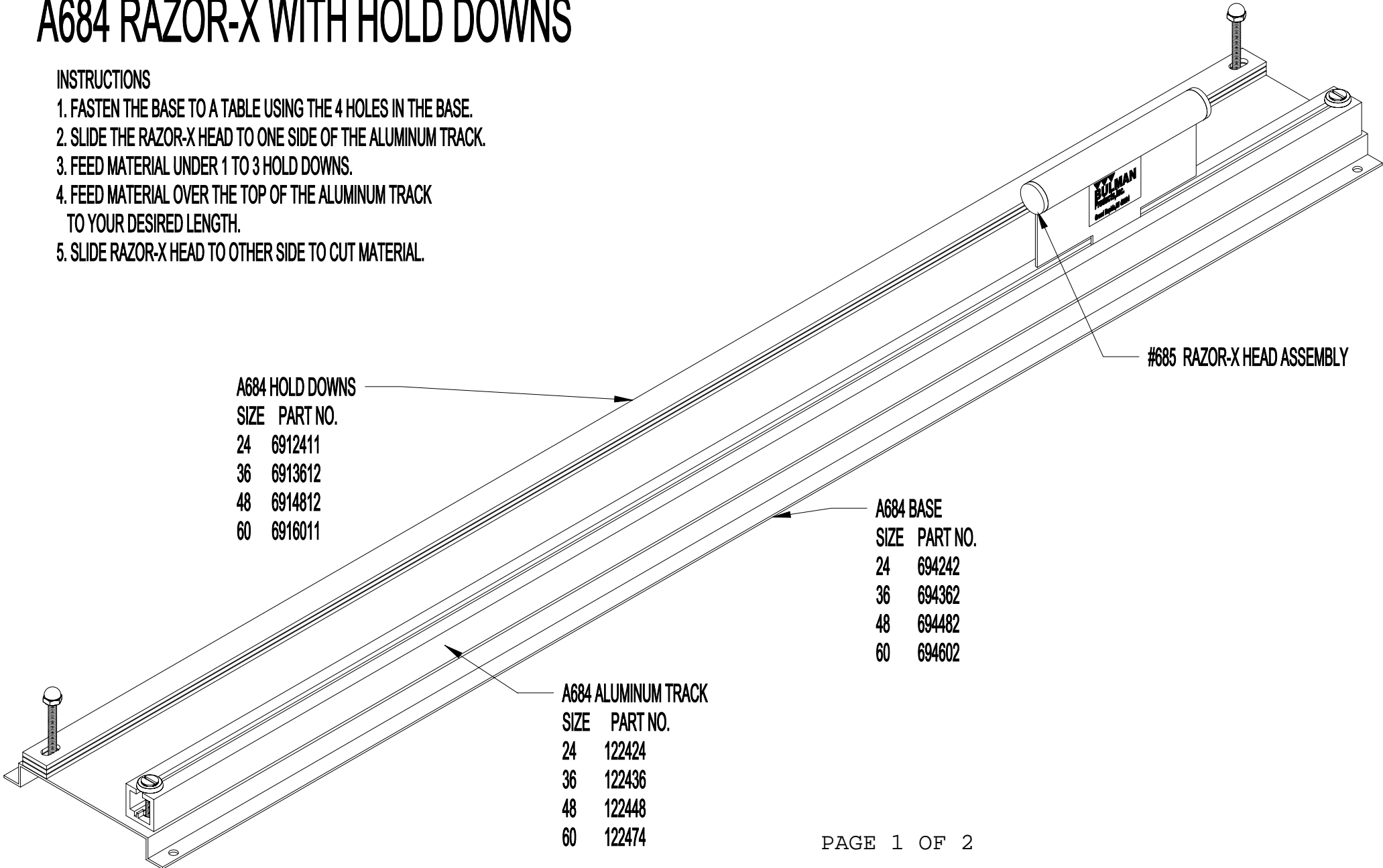

A684 HOLD DOWNS

SIZE	PART NO.
24	6912411
36	6913612
48	6914812
60	6916011

A684 BASE

SIZE	PART NO.
24	694242
36	694362
48	694482
60	694602

A684 ALUMINUM TRACK

SIZE	PART NO.
24	122424
36	122436
48	122448
60	122474

#685 RAZOR-X HEAD ASSEMBLY

1650 McReynolds Avenue, N.W.
Grand Rapids, Michigan 49504-2043
Phone: 616-363-4416 Fax: 616-363-0380
www.bulmanproducts.com

RAZOR-X SLIDE KNIFE ASSEMBLY

PART NUMBER 685

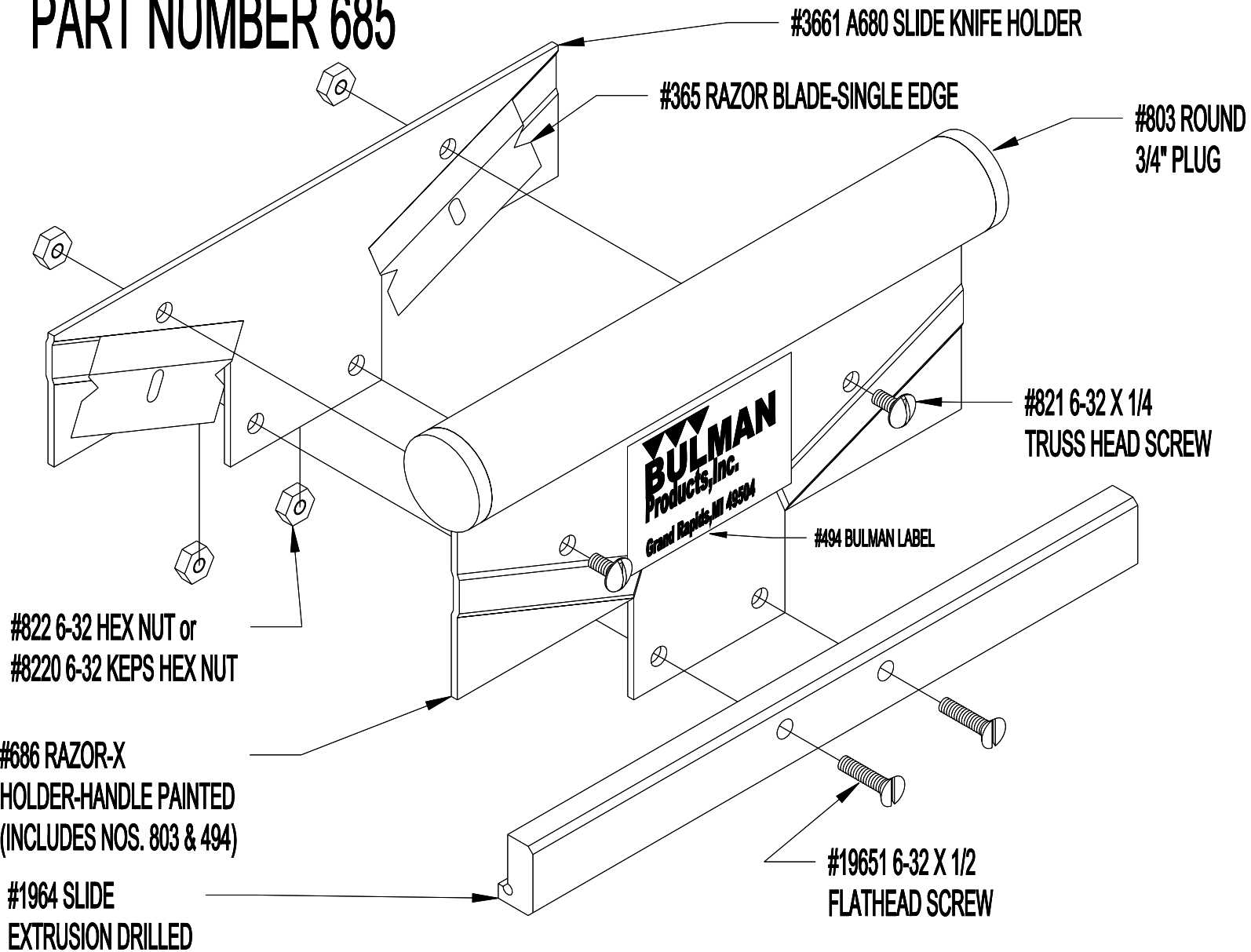

PROPERTY OF BULMAN PRODUCTS, INC.
C:\C7\A691R3DRAZRHD.PRT
2-20-2001 DRN BY MKW