



The Ultimate in Fall Protection

**Instructions for the following series products:**  
Beam Trolley Anchorage  
(Model Numbers: 2103143, 2103147, 2103149)

### USER INSTRUCTION MANUAL TROLLEY ANCHORAGE CONNECTOR

This manual is intended to meet the Manufacturer's Instructions as required by ANSI-Z359.1 and should be used as part of an employee training program as required by OSHA.

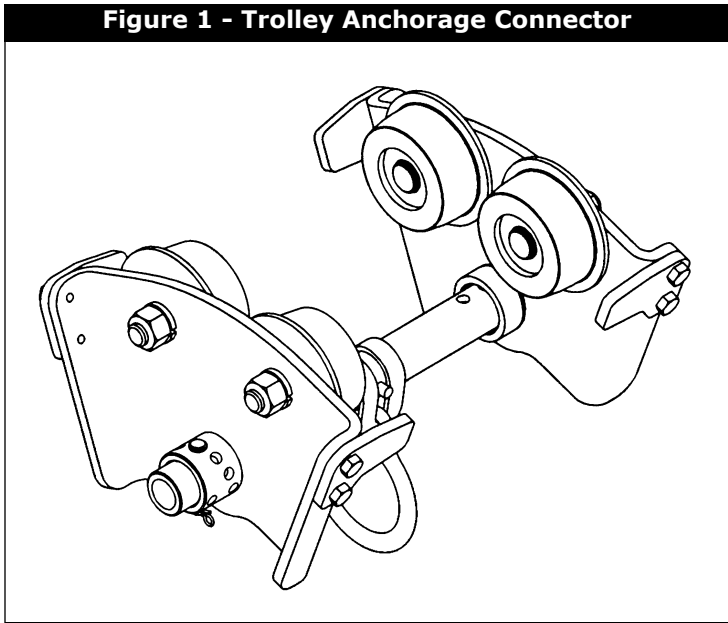

**WARNING:** This product is part of a personal restraint, work positioning, suspension, or rescue system. These instructions must be provided to the user and rescuer (see section 8.0 Terminology). The user must read and understand these instructions or have them explained to them before using this equipment. The user must read and follow the manufacturer's instructions for each component or part of the complete system. Manufacturer's instructions must be followed for proper use and maintenance of this product. Alterations or misuse of this product or failure to follow instructions may result in serious injury or death.

**IMPORTANT:** If you have questions on the use, care, or suitability of this equipment for your application, contact DBI-SALA.

**IMPORTANT:** Record the product identification information from the ID label in the inspection and maintenance log in section 10.0 of this manual.

## 1.0 APPLICATIONS

**1.1 PURPOSE:** The Trolley Anchorage Connector is designed to move along horizontal beams with an attached personal fall arrest system. This trolley is to be used only as a component of a personal fall arrest system. Do not hang, lift, or support tools or equipment from the trolley.

**A. FALL ARREST:** The trolley is used as a component of a personal fall arrest system. Personal fall arrest systems typically include a self retracting lifeline, connector to attach the self retracting lifeline to the trolley, and full body harness. A personal fall arrest system is used where a free fall is possible before the fall is arrested.

**1.2 LIMITATIONS:** Consider the following application limitations before using this equipment:

**A. BEAMS:** The trolley may be used on beam flanges 3 in. (7.6 cm) to 8 in. (20.3 cm) wide and up to 11/16 in. (1.75 cm) thick. The minimum radius the trolley can follow is 48 in. (122 cm). The beam structure must meet the strength requirements specified in section 2.4. The beam must be horizontal and level.

**B. CAPACITY:** The trolley is designed for use by persons with a combined weight (clothing, tools, etc.) of no more than 310 lbs (141 kg). Only one personal fall arrest system may be connected to a single trolley.

**C. PERSONAL FALL ARREST SYSTEM:** Personal fall arrest systems used with the trolley must meet the system requirements as specified in section 2.5.

**D. FREE FALL:** Personal fall arrest systems used with the trolley must be rigged to limit the free fall to 6 feet. See subsystem manufacturer's instructions for more information.

**E. FALL CLEARANCE:** There must be sufficient clearance below the user to arrest a fall before the user strikes the ground or other obstruction. The clearance required is dependent on the following factors:

- Elevation of Trolley
- Deceleration distance
- Worker height
- Connecting subsystem length
- Movement of harness attachment element
- Free fall distance

See personal fall arrest system manufacturer's instructions for more information.

**F. TROLLEY LOAD ANGLE:** Loads imposed on the trolley by the personal fall arrest system must remain within 30 degrees of the vertical center line of the beam. See Figure 2.

**G. ENVIRONMENTAL HAZARDS:** Use of this equipment in hazardous environments may require additional precautions to reduce the possibility of injury to the user or damage to the equipment. Hazards may include, but are not limited to; heat, extreme cold, caustic chemicals, corrosive environments, high voltage power lines, explosive or toxic gases, moving machinery, and sharp edges.

**H. TRAINING:** This equipment is intended to be installed and used by persons trained in its application and use.

**1.3 APPLICABLE STANDARDS:** Refer to applicable local, state, and federal (OSHA) requirements governing this equipment for more information on anchorage connectors and associated system components, including OSHA 1910.66, appendix C and OSHA1926.502.

## 2.0 SYSTEM REQUIREMENTS

**2.1 COMPATIBILITY OF COMPONENTS:** DBI-SALA equipment is designed for use with DBI-SALA approved components and subsystems only. Substitutions or replacements made with non-approved components or subsystems may jeopardize compatibility of equipment and may affect the safety and reliability of the complete system.

**2.2 COMPATIBILITY OF CONNECTORS:** Connectors are considered to be compatible with connecting elements when they have been designed to work together in such a way that their sizes and shapes do not cause their gate mechanisms to inadvertently open regardless of how they become oriented. Contact DBI-SALA if you have any questions about compatibility.

Connectors (hooks, carabiners, and D-rings) must be capable of supporting at least 5,000 lbs. (22.2kN). Connectors must be compatible with the anchorage or other system components. Do not use equipment that is not compatible. Non-compatible connectors may unintentionally disengage. See Figure 3. Connectors must be compatible in size, shape, and strength. Self locking snap hooks and carabiners are required by ANSI Z359.1 and OSHA, and in Canada, by CSA Z259.12.

**2.3 MAKING CONNECTIONS:** Only use self-locking snap hooks and carabiners with this equipment. Only use connectors that are suitable to each application. Ensure all connections are compatible in size, shape and strength. Do not use equipment that is not compatible. Ensure all connectors are fully closed and locked.

DBI-SALA connectors (snap hooks and carabiners) are designed to be used only as specified in each product's user's instructions. See Figure 4 for inappropriate connections. DBI-SALA snap hooks and carabiners should not be connected:

- A. To a D-ring to which another connector is attached.
- B. In a manner that would result in a load on the gate.

**NOTE:** Large throat snap hooks should not be connected to standard size D-rings or similar objects which will result in a load on the gate if the hook or D-ring twists or rotates. Large throat snap hooks are designed for use on fixed structural elements such as rebar or cross members that are not shaped in a way that can capture the gate of the hook.

- C. In a false engagement, where features that protrude from the snap hook or carabiner catch on the anchor and without visual confirmation seems to be fully engaged to the anchor point.
- D. To each other.
- E. Directly to webbing or rope lanyard or tie-back (unless the manufacturer's instructions for both the lanyard and connector specifically allow such a connection).
- F. To any object which is shaped or dimensioned such that the snap hook or carabiner will not close and lock, or that roll-out could occur.
- G. In a manner that does not allow the connector to align properly while under load.

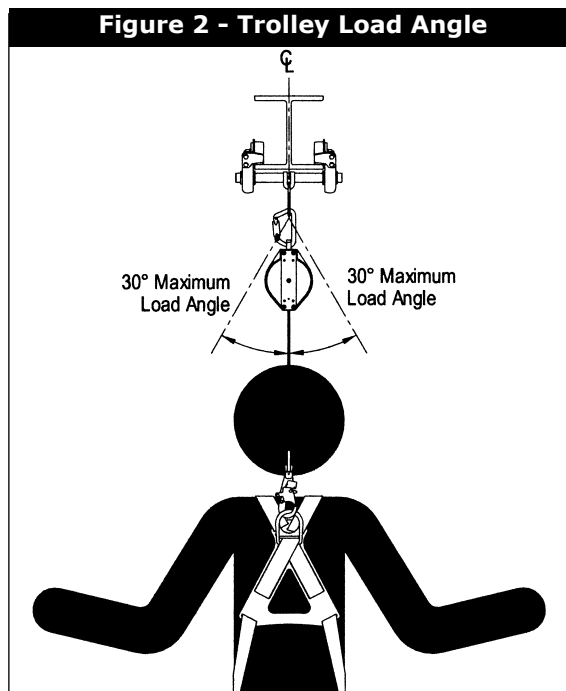

**Figure 3 - Unintentional Disengagement**

If the connecting element to which a snap hook (shown) or carabiner attaches is undersized or irregular in shape, a situation could occur where the connecting element applies a force to the gate of the snap hook or carabiner. This force may cause the gate (of either a self-locking or a non-locking snap hook) to open, allowing the snap hook or carabiner to disengage from the connecting point.

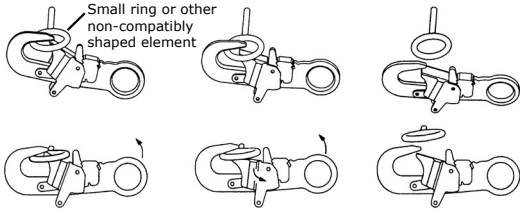

Force is applied to the Snap Hook.

The Gate presses against the Connecting Ring.

The Gate opens allowing the Snap Hook to slip off.

**Figure 4 - Inappropriate Connections**

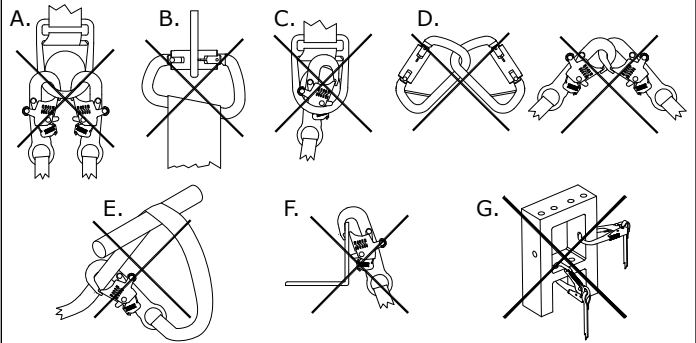

**2.4 ANCHORAGE STRUCTURE STRENGTH:** The structure to which the trolley is installed must sustain static loads in the directions permitted by the personal fall arrest system of at least 5,000 lbs. (22.2 kN) When more than one trolley is installed on the same anchorage structure, the anchorage structure strength must be multiplied by the number of personal fall arrest systems attached to the structure.

From OSHA 1926.500 and 1910.66: Anchorages used for attachment of a personal fall arrest system shall be independent of any anchorage being used to support or suspend platforms, and must support at least 5,000 lbs. (22.2 kN) per user attached; or be designed, installed, and used as part of a complete personal fall arrest system which maintains a safety factor of at least two, and is supervised by a qualified person.

**2.5 PERSONAL FALL ARREST SYSTEM:** Personal fall arrest systems used with this equipment must meet applicable local, state, and federal (OSHA) requirements. A personal fall arrest system incorporating a full body harness must be capable of arresting a user's fall with a maximum arresting force of 1,800 lbs. (816 kg), and limit the free fall distance to 6 ft. (1.8 m) or less. The deceleration distance must be 42 in. (107 cm) or less.

### 3.0 INSTALLATION AND USE

**WARNING:** Do not alter or intentionally misuse this equipment. Consult with DBI-SALA if using this equipment with components or subsystems other than those described in this manual. Some subsystem and component combinations may interfere with the operation of this equipment.

**WARNING:** Consult with your doctor if there is any reason to doubt your fitness to safely absorb the shock from a fall arrest. Age and fitness can seriously affect your ability to withstand falls. Pregnant women and minors must not use this equipment.

**3.1 BEFORE EACH USE** of this equipment inspect it according to section 5.0.

**3.2 PLAN** your fall arrest system before installing and using this equipment. Consider all factors affecting your safety during use. The following list gives some important points to consider when planning your system:

- A. ANCHORAGE BEAM:** Select a rigid anchorage beam that is capable of supporting the loads specified in section 2.4. Joints between beam sections must be flush to allow the trolley to pass over smoothly. The beam must have end stops at each end to prevent the trolley from rolling off the beam. The end stops must be sized and positioned to safely stop the trolley. The trolley should not catch or hang-up on the end stop; the trolley must be able to freely return in the opposite direction after contacting the end stop. See Figure 5.
- B. FALL CLEARANCE:** See Figure 6. There must be sufficient clearance in your fall path to prevent striking an object or lower level in the event of a fall. The amount of clearance required is dependent on the application. See personal fall arrest system manufacturer's instructions for information on calculating fall clearance.
- C. SWING FALLS:** See Figure 7. Swing falls occur when the anchorage point is not directly overhead. The force of striking an object in a swing fall may cause serious injury or death. Minimize swing falls by working as directly below the anchorage point as possible. Do not permit a swing fall if injury could occur. Swing falls will significantly increase the clearance required when a self retracting lifeline or other variable length connecting subsystem is used. If a swing fall situation exists in your application contact DBI-SALA before proceeding.
- D. SHARP EDGES:** Avoid working where parts of the system will be in contact with, or abrade against, unprotected sharp edges.
- E. AFTER A FALL:** Any equipment which has been subjected to the forces of arresting a fall or exhibits damage consistent with the effect of fall arrest forces as described in section 5, must be removed from service immediately and destroyed by the user, the rescuer, or an authorized person.
- F. RESCUE:** When using this equipment, the employer must have a rescue plan and the means at hand to implement it and communicate that plan to users, authorized persons, and rescuers.

#### 3.3 INSTALLATION:

##### ATTACHING TROLLEY TO BEAM:

**Step 1.** Measure the beam flange width to determine the adjustment hole settings on the trolley. Figure 8 shows the hole positions on the left and right adjuster dials and load bar that correspond with Table 1. See Table 1 for the adjustment hole settings for your beam flange width.

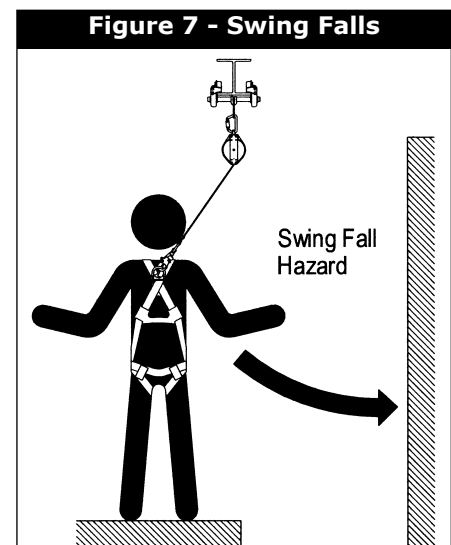
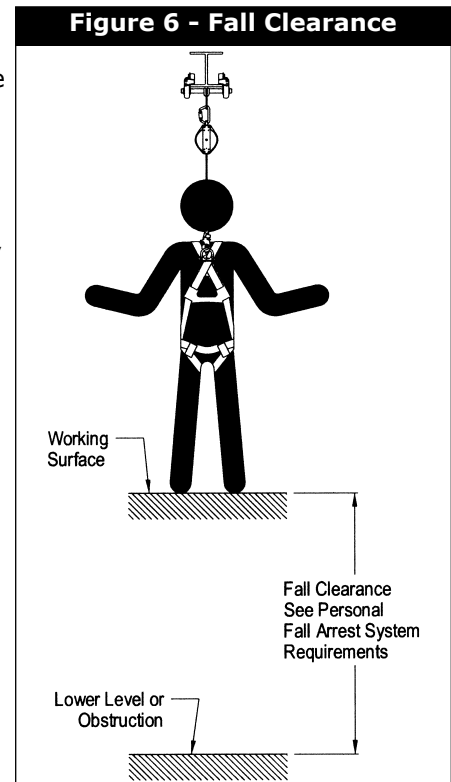
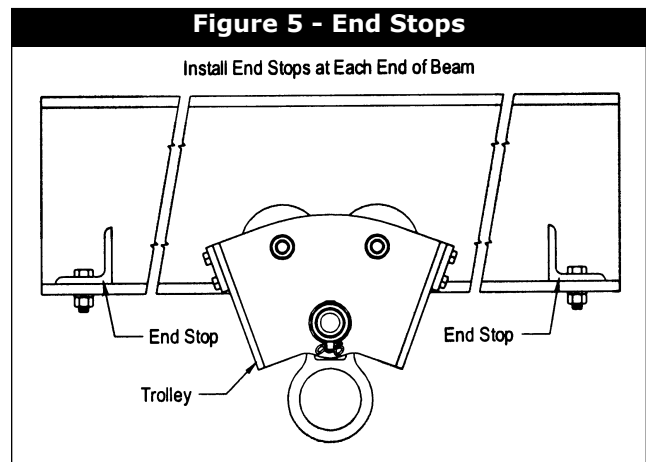

- Step 2.** To open one side of the trolley, remove the clip or cotter pin from the clevis pin and pull clevis pin out of adjuster dial. Pull the side plate with wheels and adjuster dial off the load bar.
- Step 3.** On the assembled side of the trolley, adjust the width to the required settings from Table 1 by installing the clevis pin vertically, with the clevis pin head on top (see Figure 8), through the appropriate adjuster dial and load bar holes.
- Step 4.** Place the partially assembled trolley onto the bottom flange of the beam with the D-ring hanging down. Slide the un-assembled side plate onto the load bar and align with the required adjuster dial and load bar holes. Install a clevis pin vertically, with the clevis pin head on top (see Figure 8), through the adjuster dial and load bar holes.
  - If the beam flange is too wide to install the clevis pin through the correct holes, adjust the trolley to the next larger beam flange size as specified in Table 1.
  - The distance from the trolley wheel face to the edge of the beam flange must be no more than 1/16 in. (0.16 cm). If the distance is greater than 1/16 in. (0.16 cm), adjust the trolley to the next smaller beam flange size as specified in Table 1.
- Step 5.** Install the clip or cotter pins through the clevis pins and secure them by bending back the cotter pin legs.

**WARNING:** Trolley width settings specified in Table 1 must be followed. Adjustments on the load bar must use the same setting on both sides (i.e. A - A, B - B, etc.). Adjustments on the adjuster dial must be within one unit. Failure to use correct settings may improperly load the trolley.

**IMPORTANT:** If the trolley is moved to another beam, or if the cotter pins are removed, cotter pins must be replaced. Use 5/64 x 3/4", 18-8 stainless steel cotter pins or Pivot Point bow-tie™ clip cotter pins (bow 72). If you are using Pivot Point bow-tie™ clips, they are reusable.

- 3.4 ATTACHING PERSONAL FALL ARREST SYSTEM TO TROLLEY:** Attach your personal fall arrest system to the anchorage point indicated in Figure 8. When using a hook or carabiner to connect to the anchorage, ensure roll-out cannot occur. Roll-out occurs when interference between the hook and mating connector causes the hook gate to unintentionally open and release. Self locking snap hooks and carabiners should be used to reduce the possibility of roll-out. Do not use hooks or connectors that will not completely close over the attachment object. Do not connect snap hooks or carabiners to each other. See personal fall arrest system manufacturer's instructions for connecting subsystems used with the trolley.

## 4.0 TRAINING

- 4.1** The user and purchaser of this equipment must be familiar with the instructions, operating characteristics, application limits, and the consequences of improper use of this equipment. Users and purchasers must be trained in the correct care and use of this equipment.

**WARNING:** Training must be conducted without exposing the trainee to a fall hazard. Training should be repeated on a periodic basis.

## 5.0 INSPECTION

### 5.1 FREQUENCY:

- **BEFORE EACH USE:** Inspect trolley according to sections 5.2 and 5.3.
- **ANNUALLY:** The trolley must be inspected by a competent person other than the user. See sections 5.2 and 5.3 for inspection guidelines.

### 5.2 INSPECTION STEPS:

- Step 1.** Inspect trolley for damage. Look for cracks or deformities. Look for excessive wear or damage to the anchorage point. All fasteners must be secure.
- Step 2.** Inspect trolley wheels. All wheels should turn freely and be undamaged.
- Step 3.** Inspect entire unit for corrosion.
- Step 4.** The warning label must be present and fully legible. See section 9.0.
- Step 5.** Record inspection results in section 10.0.

**WARNING:** If this equipment is subjected to the forces of a fall arrest, it must be removed from service and destroyed, or returned to DBI-SALA for inspection and repair.

- 5.3** If inspection reveals an unsafe or defective condition remove from service and destroy or contact DBI-SALA for repair.

**Figure 8 - Attaching Trolley To Beam - Anchorage Point**

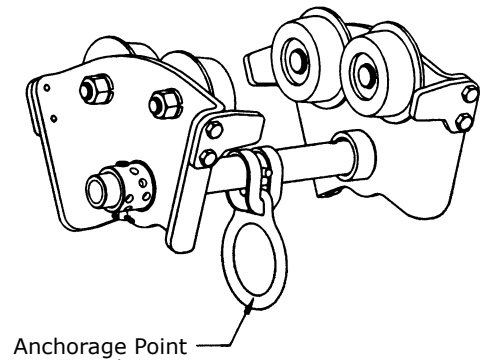
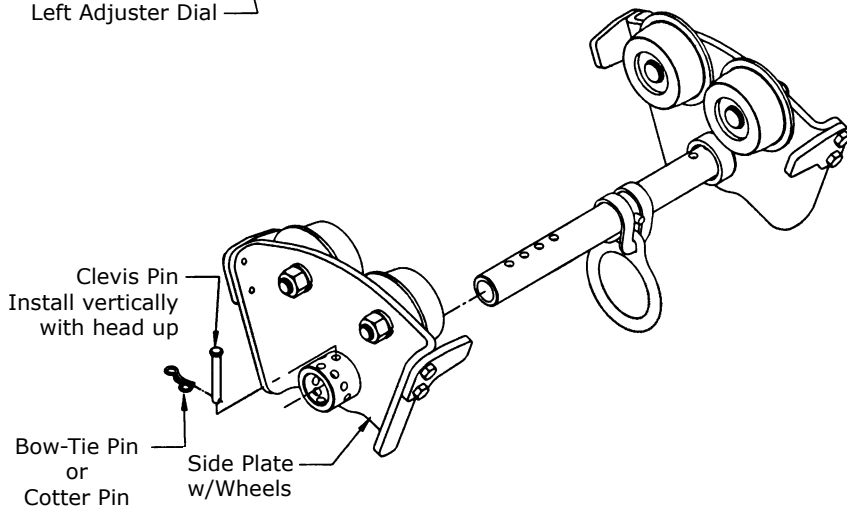
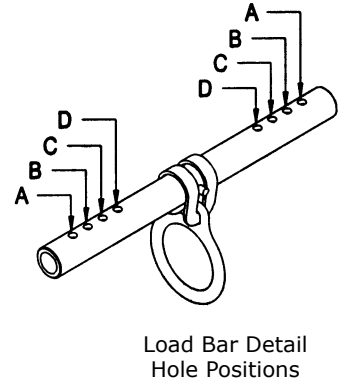
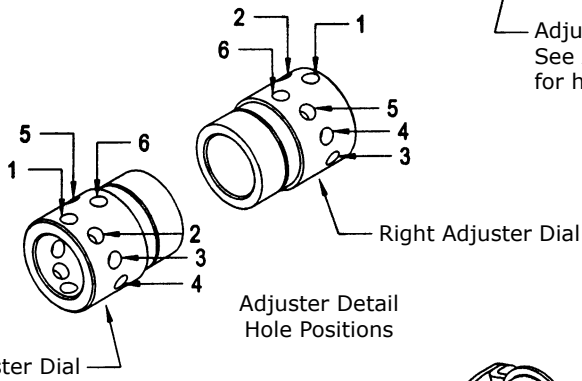
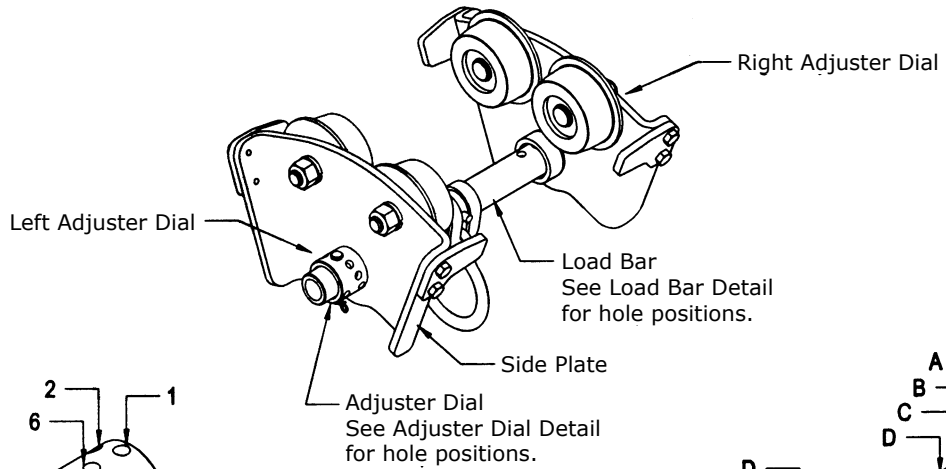
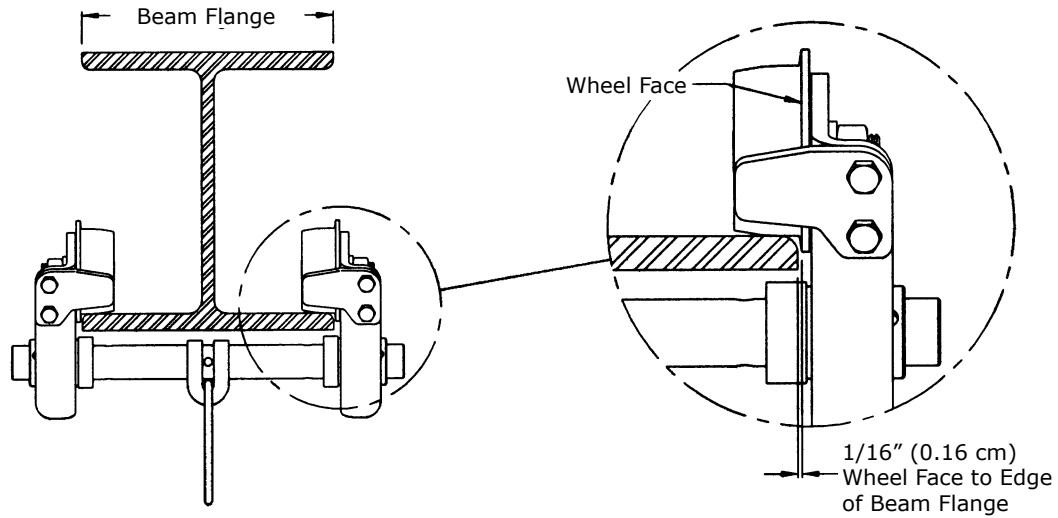

**Table 1 - Trolley Width Adjustment**

| <b>Beam Flange Width (in inches)</b> |                                     | <b>Load Bar Holes<br/>(Both Sides)</b> | <b>Left Adjuster<br/>Dial Hole</b> | <b>Right Adjuster<br/>Dial Hole</b> |
|--------------------------------------|-------------------------------------|--|------------------------------------|-------------------------------------|
| <b>From</b>                          | <b>Up to, but not<br/>including</b> |  |                                    |                                     |
| 3                                    | 3 1/8                               | D                                      | 1                                  | 1                                   |
| 3 1/8                                | 3 1/4                               | D                                      | 1                                  | 2                                   |
| 3 1/4                                | 3 3/8                               | D                                      | 2                                  | 2                                   |
| 3 3/8                                | 3 1/2                               | D                                      | 2                                  | 3                                   |
| 3 1/2                                | 3 5/8                               | D                                      | 3                                  | 3                                   |
| 3 5/8                                | 3 3/4                               | D                                      | 3                                  | 4                                   |
| 3 3/4                                | 3 7/8                               | D                                      | 4                                  | 4                                   |
| 3 7/8                                | 4                                   | D                                      | 4                                  | 5                                   |
| 4                                    | 4 1/8                               | D                                      | 5                                  | 5                                   |
| 4 1/8                                | 4 1/4                               | D                                      | 5                                  | 6                                   |
| 4 1/4                                | 4 3/8                               | C                                      | 1                                  | 1                                   |
| 4 3/8                                | 4 1/2                               | C                                      | 1                                  | 2                                   |
| 4 1/2                                | 4 5/8                               | C                                      | 2                                  | 2                                   |
| 4 5/8                                | 4 3/4                               | C                                      | 2                                  | 3                                   |
| 4 3/4                                | 4 7/8                               | C                                      | 3                                  | 3                                   |
| 4 7/8                                | 5                                   | C                                      | 3                                  | 4                                   |
| 5                                    | 5 1/8                               | C                                      | 4                                  | 4                                   |
| 5 1/8                                | 5 1/4                               | C                                      | 4                                  | 5                                   |
| 5 1/4                                | 5 3/8                               | C                                      | 5                                  | 5                                   |
| 5 3/8                                | 5 1/2                               | C                                      | 5                                  | 6                                   |
| 5 1/2                                | 5 5/8                               | B                                      | 1                                  | 1                                   |
| 5 5/8                                | 5 3/4                               | B                                      | 1                                  | 2                                   |
| 5 3/4                                | 5 7/8                               | B                                      | 2                                  | 2                                   |
| 5 7/8                                | 6                                   | B                                      | 2                                  | 3                                   |
| 6                                    | 6 1/8                               | B                                      | 3                                  | 3                                   |
| 6 1/8                                | 6 1/4                               | B                                      | 3                                  | 4                                   |
| 6 1/4                                | 6 3/8                               | B                                      | 4                                  | 4                                   |
| 6 3/8                                | 6 1/2                               | B                                      | 4                                  | 5                                   |
| 6 1/2                                | 6 5/8                               | B                                      | 5                                  | 5                                   |
| 6 5/8                                | 6 3/4                               | B                                      | 5                                  | 6                                   |
| 6 3/4                                | 6 7/8                               | A                                      | 1                                  | 1                                   |
| 6 7/8                                | 7                                   | A                                      | 1                                  | 2                                   |
| 7                                    | 7 1/8                               | A                                      | 2                                  | 2                                   |
| 7 1/8                                | 7 1/4                               | A                                      | 2                                  | 3                                   |
| 7 1/4                                | 7 3/8                               | A                                      | 3                                  | 3                                   |
| 7 3/8                                | 7 1/2                               | A                                      | 3                                  | 4                                   |
| 7 1/2                                | 7 5/8                               | A                                      | 4                                  | 4                                   |
| 7 5/8                                | 7 3/4                               | A                                      | 4                                  | 5                                   |
| 7 3/4                                | 7 7/8                               | A                                      | 5                                  | 5                                   |
| 7 7/8                                | 8                                   | A                                      | 5                                  | 6                                   |
| 8                                    | ---                                 | A                                      | 6                                  | 6                                   |

## **6.0 MAINTENANCE, SERVICING, STORAGE**

- 6.1 MAINTENANCE:** Clean the trolley using water and mild detergent. Wipe dry with a clean cloth and hang to air dry. Do not force dry with heat. An excessive build-up of dirt, paint, etc. may prevent the trolley from working correctly. No lubrication is required.
- 6.2 SERVICING:** Servicing must be completed by an authorized service center. Authorization must be in writing.
- 6.3 STORAGE:** Store this equipment in a cool, dry, clean environment. Inspect the trolley after extended storage.

## **7.0 SPECIFICATIONS**

### **7.1 MATERIALS:**

#### **2103143**

**TROLLEY:** Steel Frame, shielded wheel bearings

**LOAD BAR:** Alloy steel

**D-RING:** Alloy steel

**PIVOT POINT BOW-TIE™ CLIP COTTER PIN:** bow 72

#### **2103147**

**TROLLEY:** 304 stainless steel frame

**LOAD BAR:** 303 stainless steel

**BEARINGS:** 440 stainless steel

**WHEELS:** 303 stainless steel

**ADJUSTERS:** 303 stainless steel

**D-RING:** Forged 304 stainless steel

**FASTENERS:** 18-8 stainless steel

**COTTER PINS:** 5/64 in. x 3/4 in., 18-8 stainless steel



## 7.2 DIMENSIONS (IN INCHES):

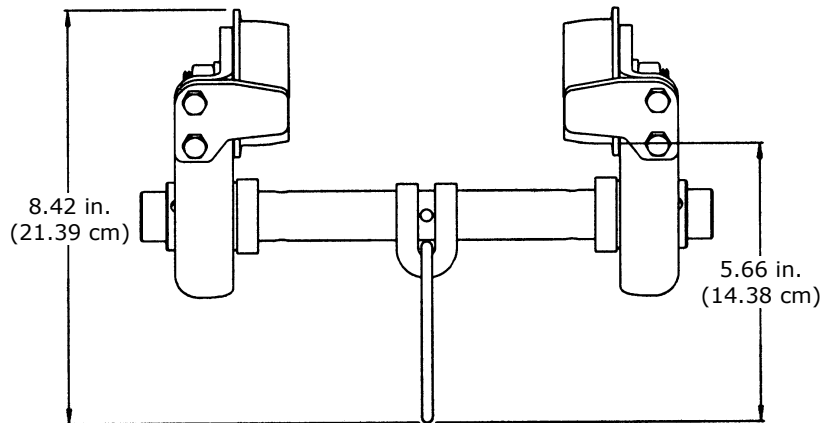
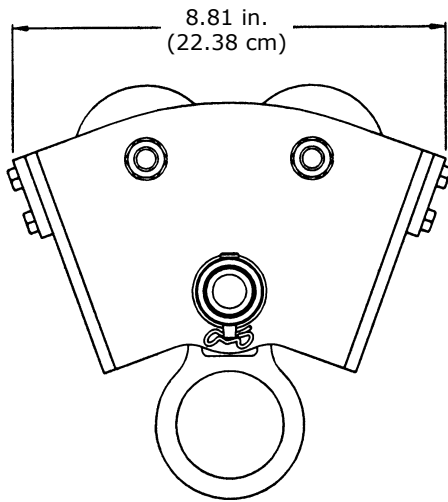
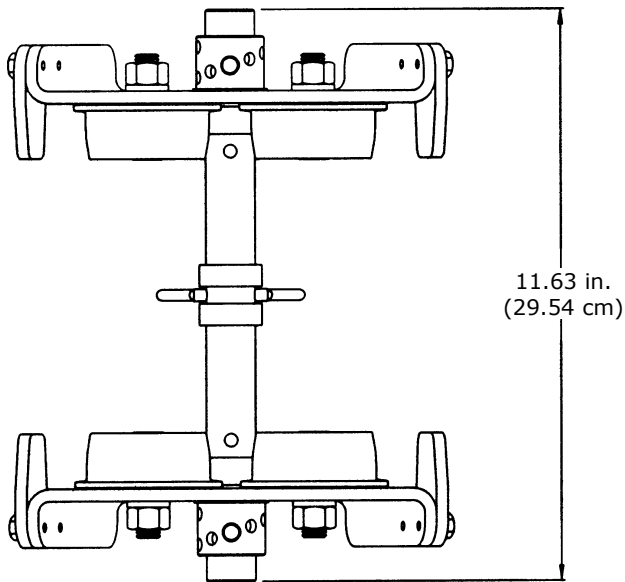

## 8.0 TERMINOLOGY

**AUTHORIZED PERSON:** A person assigned by the employer to perform duties at a location where the person will be exposed to a fall hazard (otherwise referred to as "user" for the purpose of these instructions).

**RESCUER:** Person or persons other than the rescue subject acting to perform an assisted rescue by operation of a rescue system.

**CERTIFIED ANCHORAGE:** An anchorage for fall arrest, positioning, restraint, or rescue systems that a qualified person certifies to be capable of supporting the potential fall forces that could be encountered during a fall or that meet the criteria for a certified anchorage prescribed in this standard.

**QUALIFIED PERSON:** A person with a recognized degree or professional certificate and with extensive knowledge, training, and experience in the fall protection and rescue field who is capable of designing, analyzing, evaluating and specifying fall protection and rescue systems to the extent required by this standard.

**COMPETENT PERSON:** One who is capable of identifying existing and predictable hazards in the surroundings or working conditions which are unsanitary, hazardous, or dangerous to employees, and who has authorization to take prompt corrective measures to eliminate them.

**9.0 LABELING**

**9.1** This label must be present and fully legible:

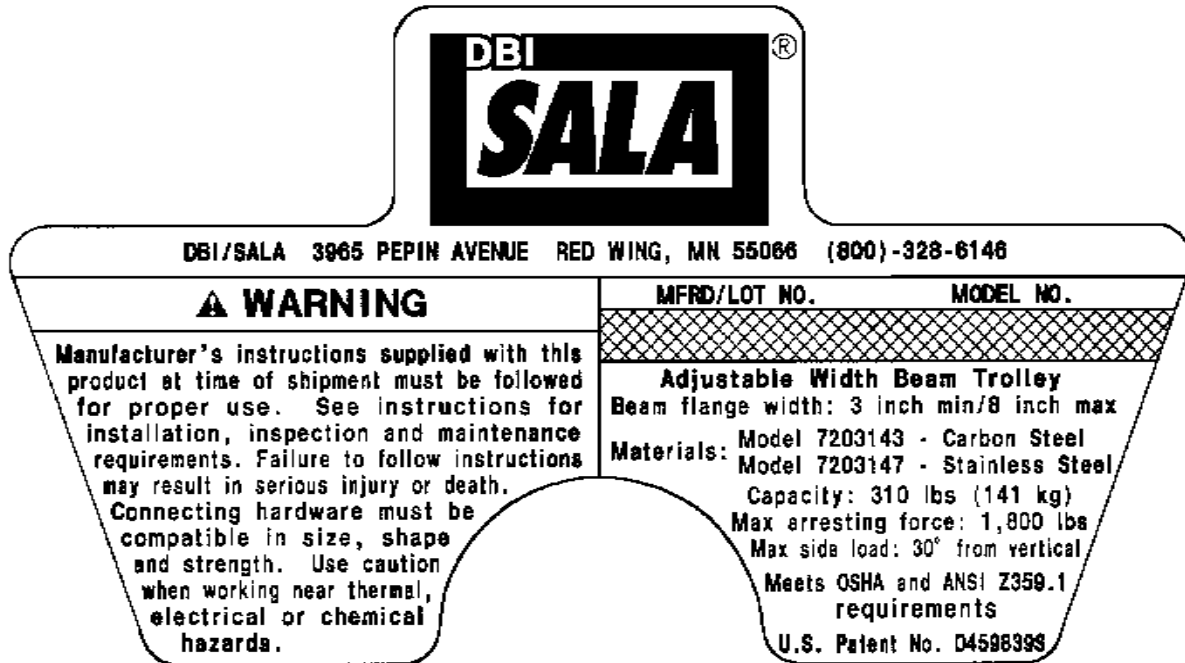



## LIMITED LIFETIME WARRANTY

**Warranty to End User:** D B Industries, Inc., dba CAPITAL SAFETY USA ("CAPITAL SAFETY") warrants to the original end user ("End User") that its products are free from defects in materials and workmanship under normal use and service. This warranty extends for the lifetime of the product from the date the product is purchased by the End User, in new and unused condition, from a CAPITAL SAFETY authorized distributor. CAPITAL SAFETY'S entire liability to End User and End User's exclusive remedy under this warranty is limited to the repair or replacement in kind of any defective product within its lifetime (as CAPITAL SAFETY in its sole discretion determines and deems appropriate). No oral or written information or advice given by CAPITAL SAFETY, its distributors, directors, officers, agents or employees shall create any different or additional warranties or in any way increase the scope of this warranty. CAPITAL SAFETY will not accept liability for defects that are the result of product abuse, misuse, alteration or modification, or for defects that are due to a failure to install, maintain, or use the product in accordance with the manufacturer's instructions.

CAPITAL SAFETY'S WARRANTY APPLIES ONLY TO THE END USER. THIS WARRANTY IS THE ONLY WARRANTY APPLICABLE TO OUR PRODUCTS AND IS IN LIEU OF ALL OTHER WARRANTIES AND LIABILITIES, EXPRESSED OR IMPLIED. CAPITAL SAFETY EXPRESSLY EXCLUDES AND DISCLAIMS ANY IMPLIED WARRANTIES OF MERCHANTABILITY OR FITNESS FOR A PARTICULAR PURPOSE, AND SHALL NOT BE LIABLE FOR INCIDENTAL, PUNITIVE OR CONSEQUENTIAL DAMAGES OF ANY NATURE, INCLUDING WITHOUT LIMITATION, LOST PROFITS, REVENUES, OR PRODUCTIVITY, OR FOR BODILY INJURY OR DEATH OR LOSS OR DAMAGE TO PROPERTY, UNDER ANY THEORY OF LIABILITY, INCLUDING WITHOUT LIMITATION, CONTRACT, WARRANTY, STRICT LIABILITY, TORT (INCLUDING NEGLIGENCE) OR OTHER LEGAL OR EQUITABLE THEORY.



The Ultimate in Fall Protection

### **CSG USA & Latin America**

3833 SALA Way  
Red Wing, MN 55066-5005  
Toll Free: 800.328.6146  
Phone: 651.388.8282  
Fax: 651.388.5065  
solutions@capitalsafety.com

### **CSG Canada**

260 Export Boulevard  
Mississauga, ON L5S 1Y9  
Phone: 905.795.9333  
Toll-Free: 800.387.7484  
Fax: 888.387.7484  
info.ca@capitalsafety.com

### **CSG Northern Europe**

5a Merse Road  
North Moons, Moat  
Reditch, Worcestershire, UK  
B98 9HL  
Phone: + 44 (0)1527 548 000  
Fax: + 44 (0)1527 591 000  
csgne@capitalsafety.com

### **CSG EMEA (Europe, Middle East, Africa)**

Le Broc Center  
Z.I. 1ère Avenue  
5600 M B.P. 15 06511  
Carros  
Le Broc Cedex  
France  
Phone: + 33 4 97 10 00 10  
Fax: + 33 4 93 08 79 70  
information@capitalsafety.com

### **CSG Australia & New Zealand**

95 Derby Street  
Silverwater  
Sydney NSW 2128  
AUSTRALIA  
Phone: +(61) 2 8753 7600  
Toll-Free : 1 800 245 002 (AUS)  
Toll-Free : 0800 212 505 (NZ)  
Fax: +(61) 2 87853 7603  
sales@capitalsafety.com.au

### **CSG Asia**

*Singapore:*  
16S, Enterprise Road  
Singapore 627666  
Phone: +65 - 65587758  
Fax: +65 - 65587058  
inquiry@capitalsafety.com

### *Shanghai:*

Rm 1406, China Venturetech Plaza  
819 Nan Jing Xi Rd,  
Shanghai 200041, P R China  
Phone: +86 21 62539050  
Fax: +86 21 62539060

[www.capitalsafety.com](http://www.capitalsafety.com)

