

Assembly Instructions	Instrucciones de Ensamblaje	Directives d'assemblage
Customer Service US: 1-800-645-2986	Servicio de atención al Cliente México: 01.800.681.6940	Service à la clientèle Canada: 888-645-2986

Industrial Pedestal Fan

Models: 585279 585280

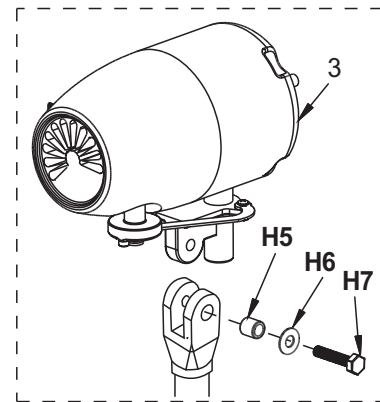
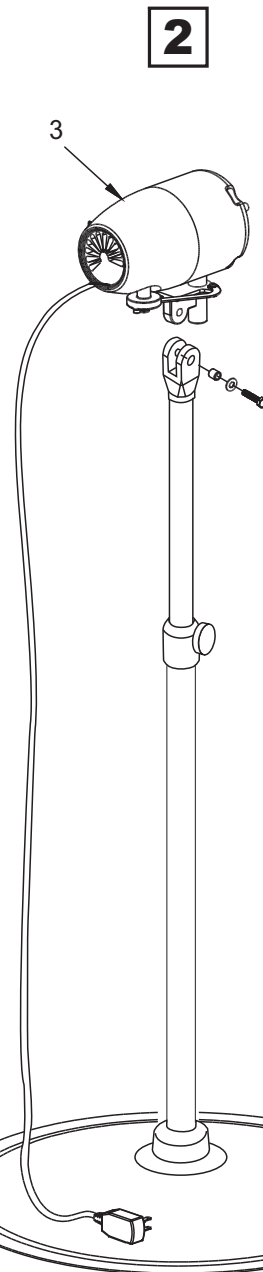
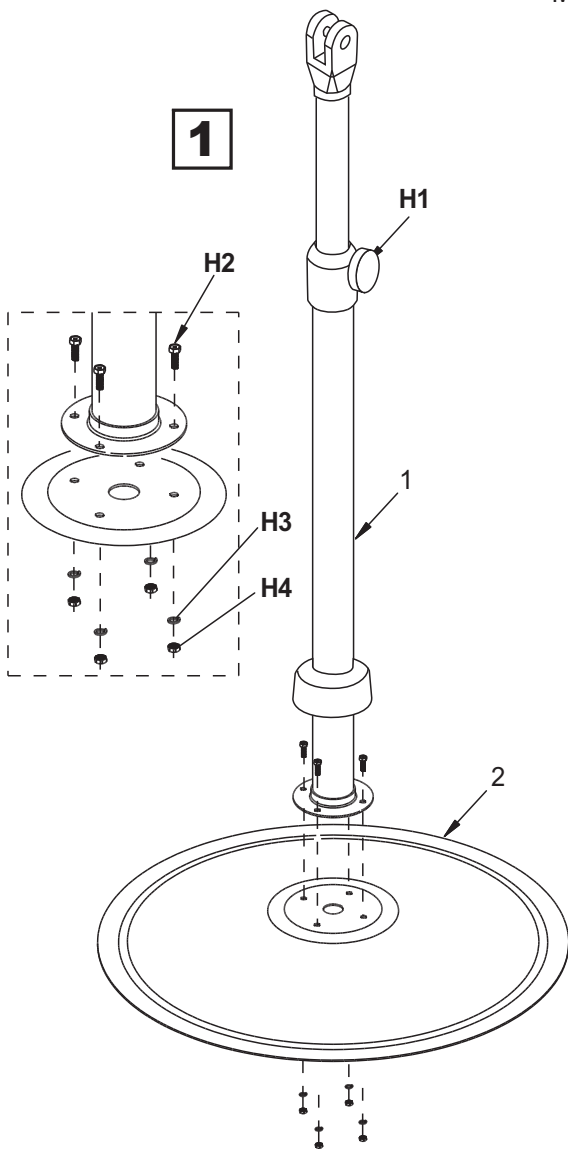

CONTENTS		
Ref.	Qty.	Description
1	1	Post
2	1	Base Plate
3	1	Fan Motor
4	1	Back Shroud
5	1	Fan Blade
6	1	Cover Shroud
H1	1	M6 x 1.0 Adjustment Knob
H2	8	M6 x 1.0 x 18mm Lg. Hex Bolt
H3	8	Split Washer
H4	4	M6 x 1.0mm Hex Nut
H5	1	Bushing
H6	1	Plain Washer
H7	1	M10 x 1.5 x50mm Lg. Hex Bolt
H8	1	4mm Allen Key

CAUTION
Make sure all nuts and bolts are fully tightened before assembling fan motor.

Industrial Pedestal Fan

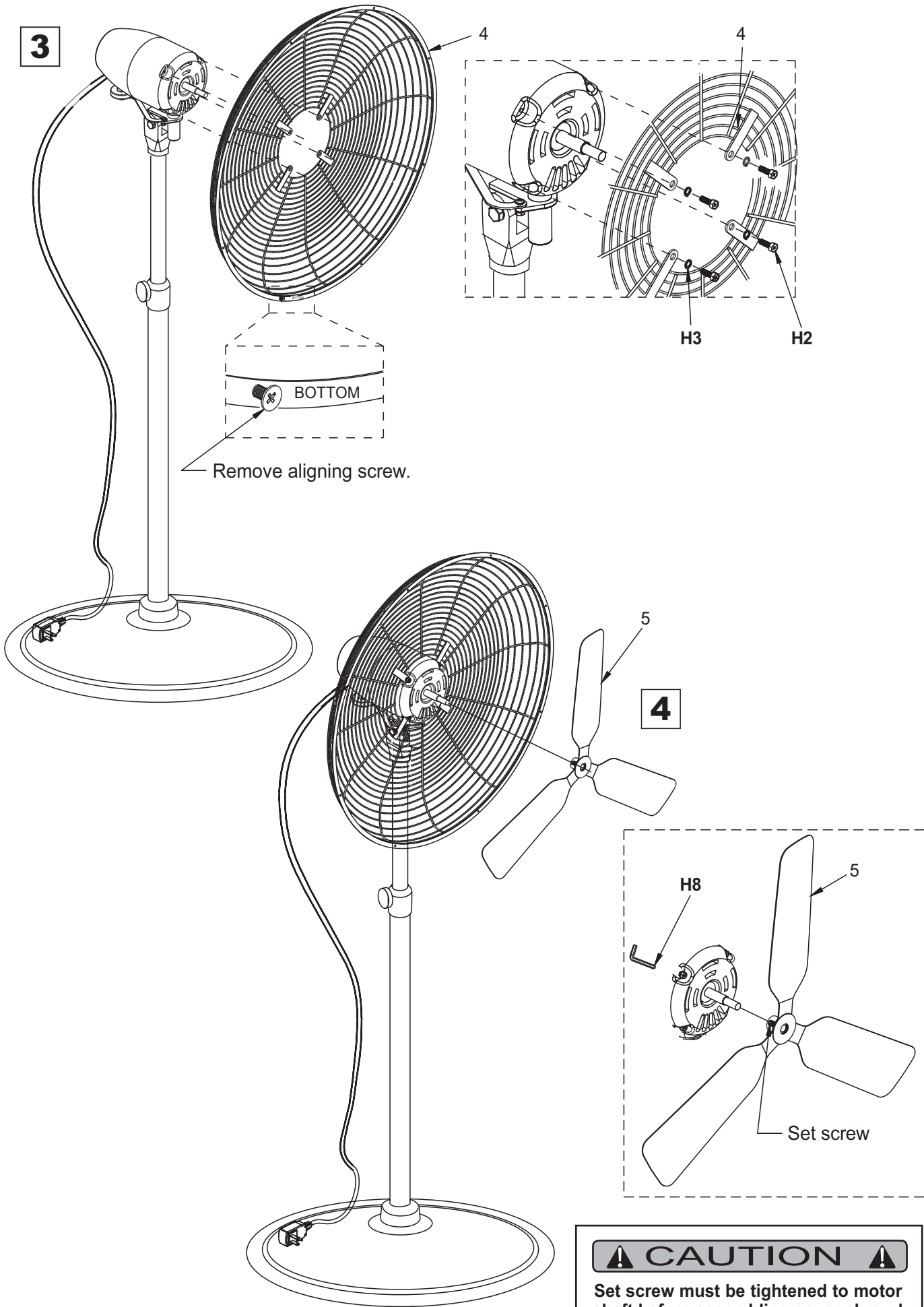

⚠ CAUTION ⚠
Set screw must be tightened to motor shaft before assembling cover shroud.

Industrial Pedestal Fan

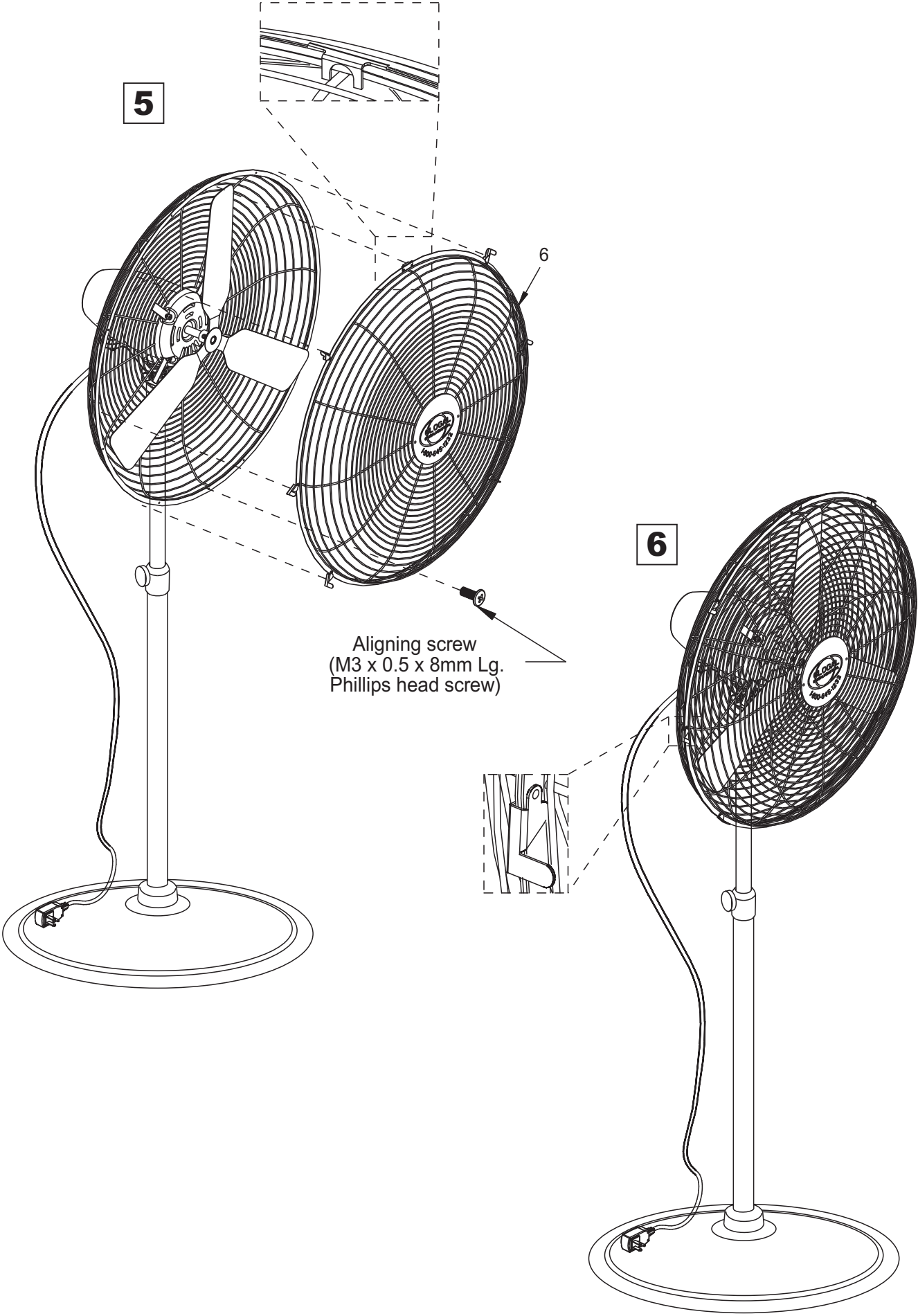

Industrial Pedestal Fan

CAUTION
Unplug prior to adjusting.

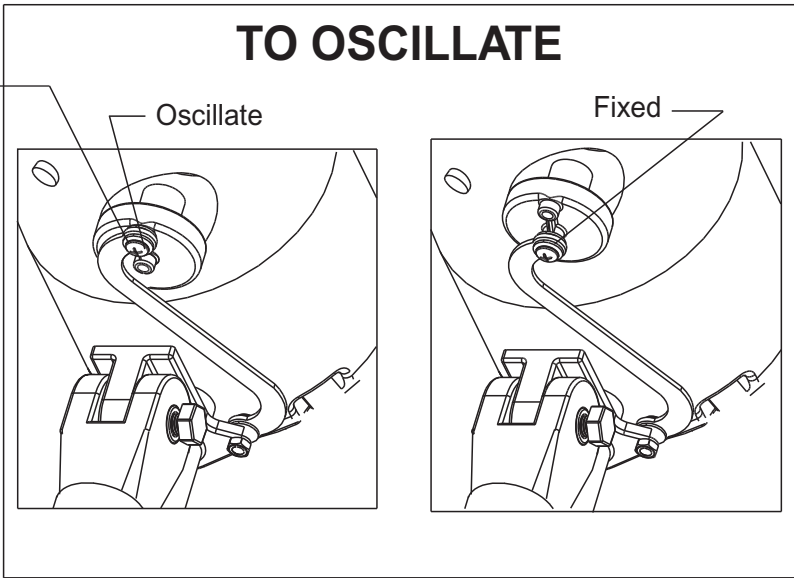

M6 x 1.0 Phillips shoulder screw

7

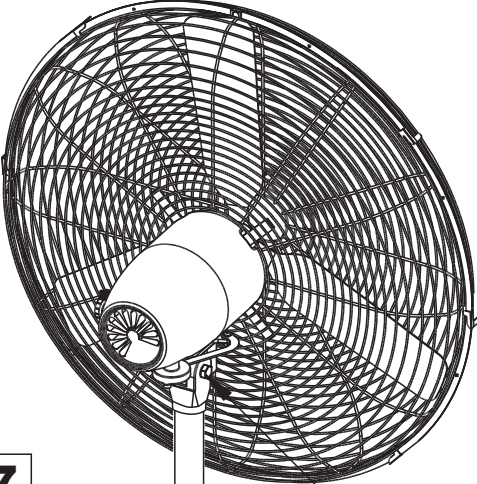

Angle adjustment bolt

Height adjustment knob

M5 x 0.8 x 8mm
Phillips pan head screw

Speed selector

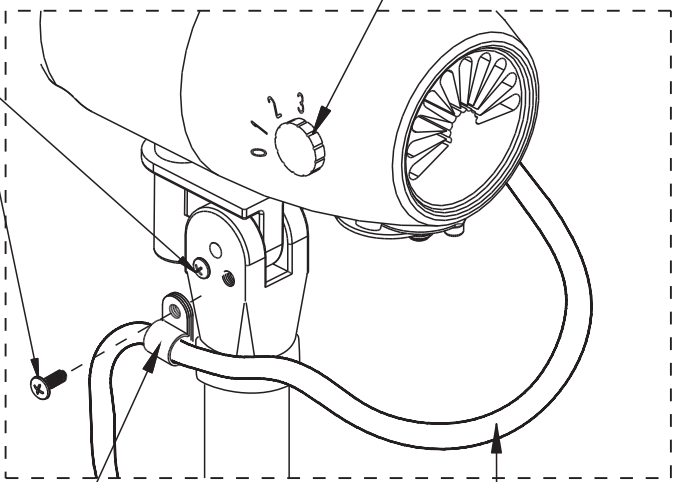

Power cord clamp

Power cord

Assembly Instructions

Customer Service
US: 1-800-645-2986

Instrucciones de Ensamblaje

Servicio de atención al Cliente
México: 01.800.681.6940

Directives d'assemblage







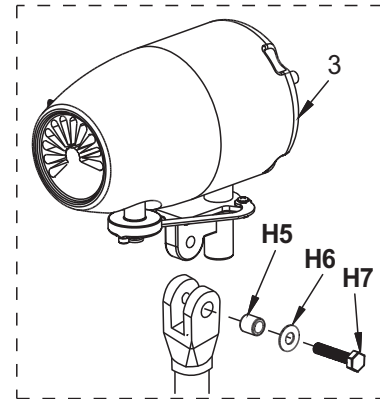
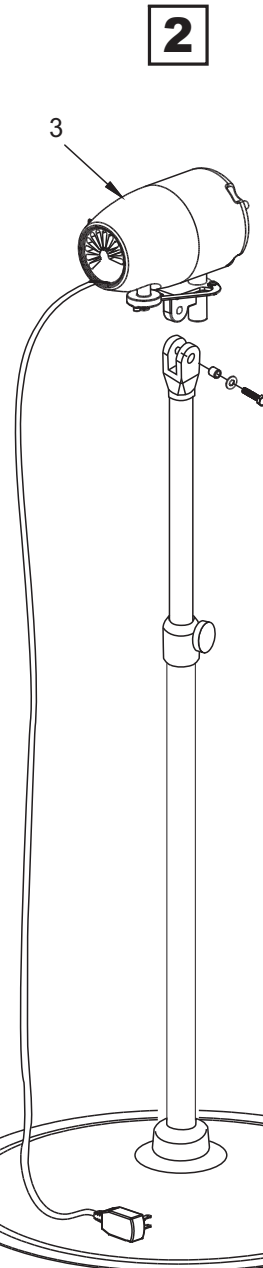
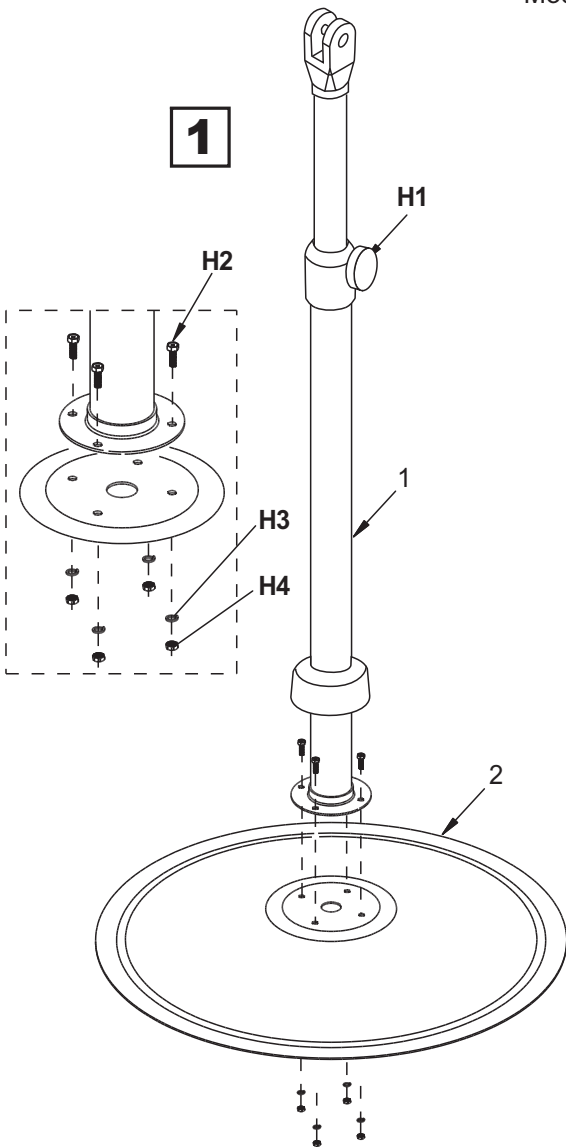

Service à la clientèle
Canada: 888-645-2986

Ventilador de pie industrial

Modelos: 585279 585280

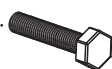

CONTENIDOS

Ref.	Cant.	Descripción
1	1	Poste
2	1	Placa Base
3	1	Motor
4	1	Cubierta Trasera
5	1	Aspas
6	1	Cubierta Carcaza
H1	1	Perilla Adjustment M6 x1.0 
H2	8	Perno de Cabeza Hexagonal de M6 x 1.0 x 18mm Lg. 
H3	8	Arandela Partida 
H4	4	Tuerca Hexagonal de M6 x 1.0 
H5	1	Buje 
H6	1	Arandela Plana 
H7	1	Perno de Cabeza Hexagonal de M10 x 1.5 x 50mm Lg. 
H8	1	Llave Hexagonal 4mm 

ADVERTENCIA

Asegúrate que todas las tuercas y tornillos estén completamente apretados antes de ensamblar el motor del ventilador.

Ventilador de pie industrial

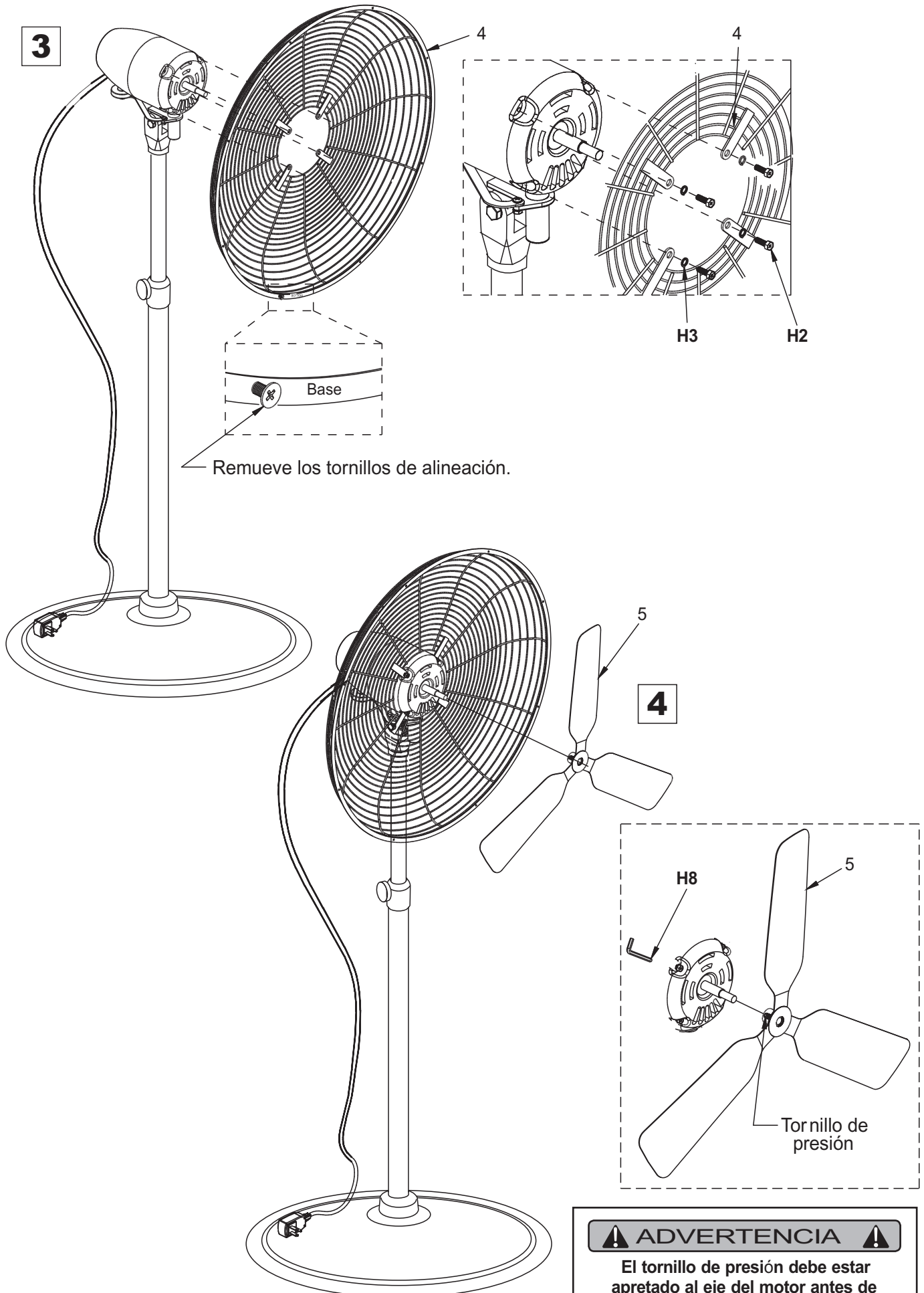

Ventilador de pie industrial

5

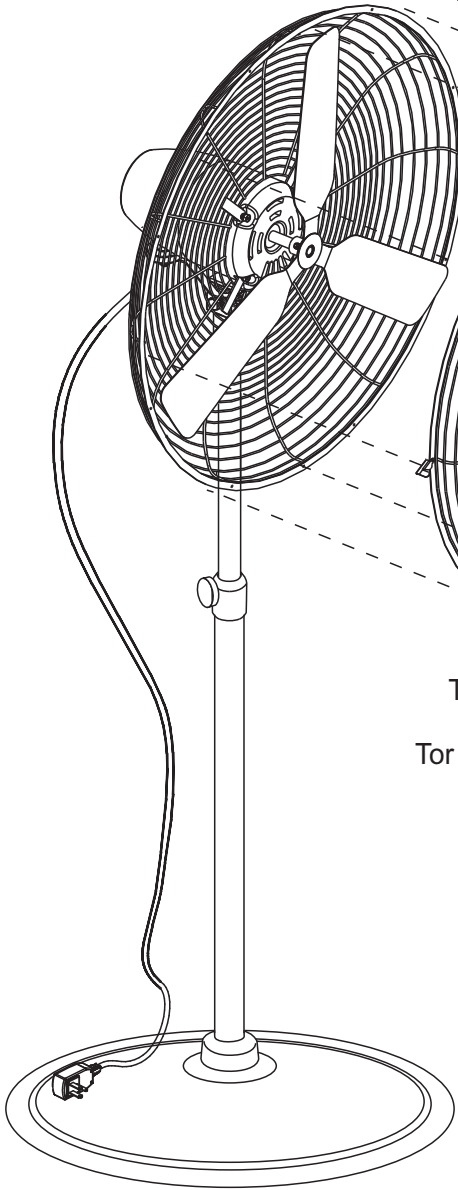
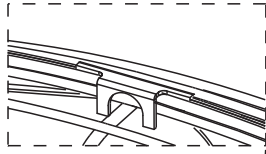

Tornillo de alineación.
(M3 x 0.5 x 8mm Lg.
Tornillo de cabeza Phillips)



6

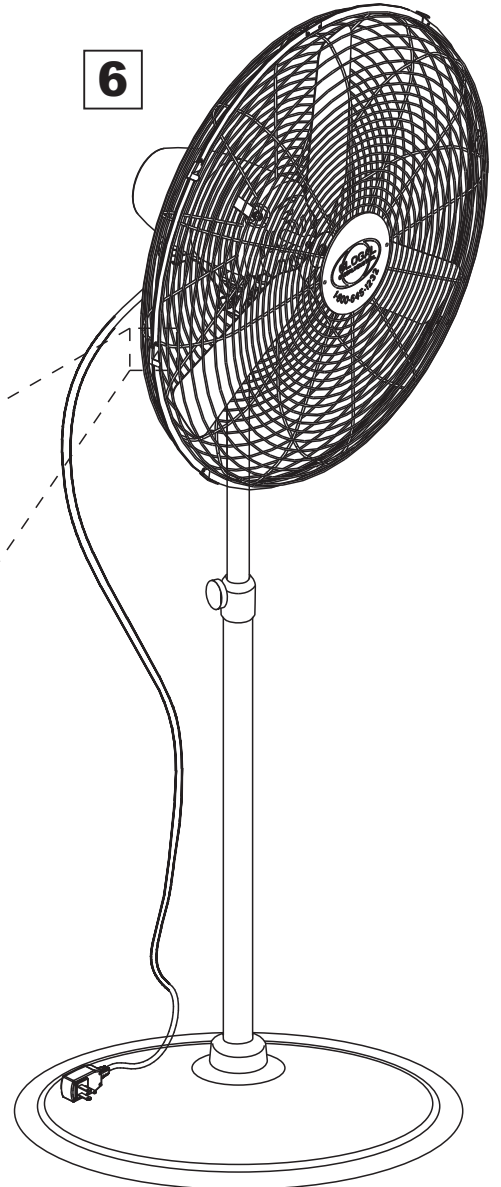

Ventilador de pie industrial

⚠ ADVERTENCIA ⚠
Retire antes de ajustar.

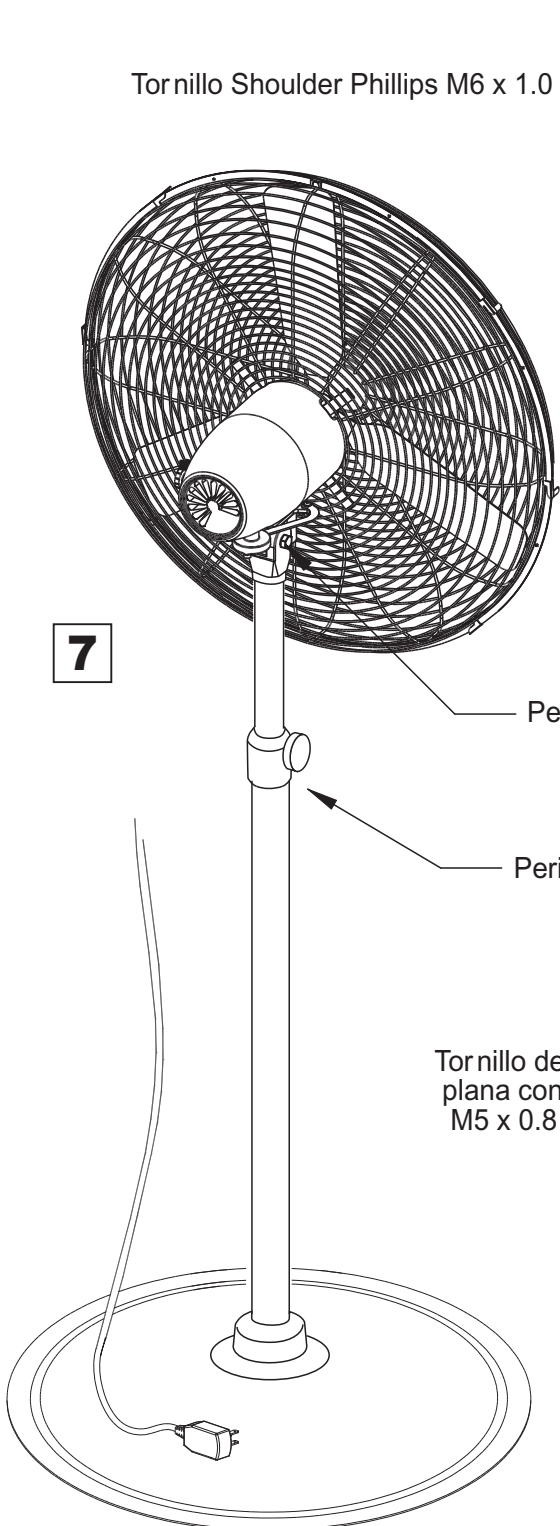

Tornillo Shoulder Phillips M6 x 1.0

Perno de ajuste de ángulo

Perilla de ajuste de altura

Tornillo de cabeza plana con ranura M5 x 0.8 x 8mm

Abrazadera del cable de alimentación

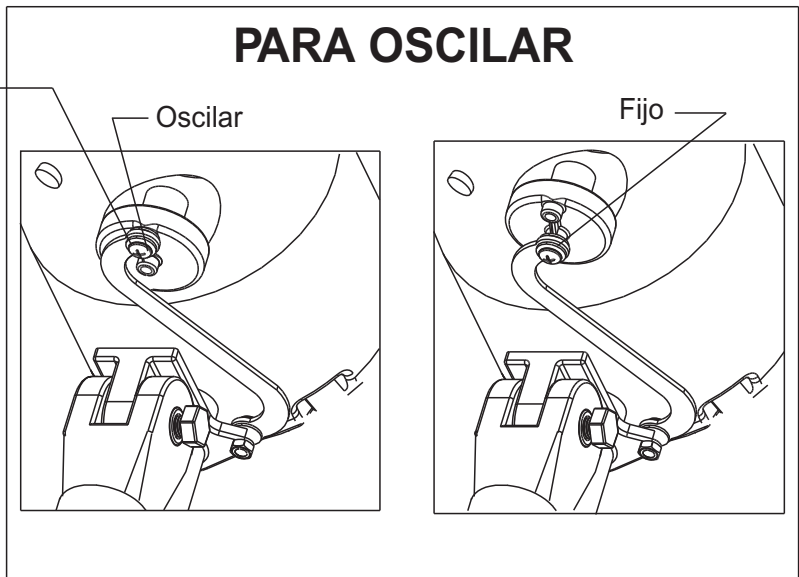

PARA OSCILAR

Oscilar

Fijo

Selector de velocidad

0 1 2 3

Cable de alimentación

Assembly Instructions

Customer Service
US: 1-800-645-2986

Instrucciones de Ensamblaje

Servicio de atención al Cliente
México: 01.800.681.6940

Directives d'assemblage

Service à la clientèle
Canada: 888-645-2986

Ventilateur industriel sur pied

Modèles : 585279 585280

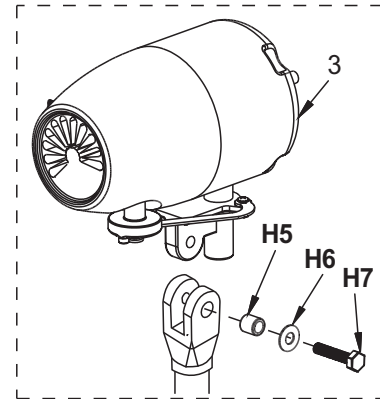
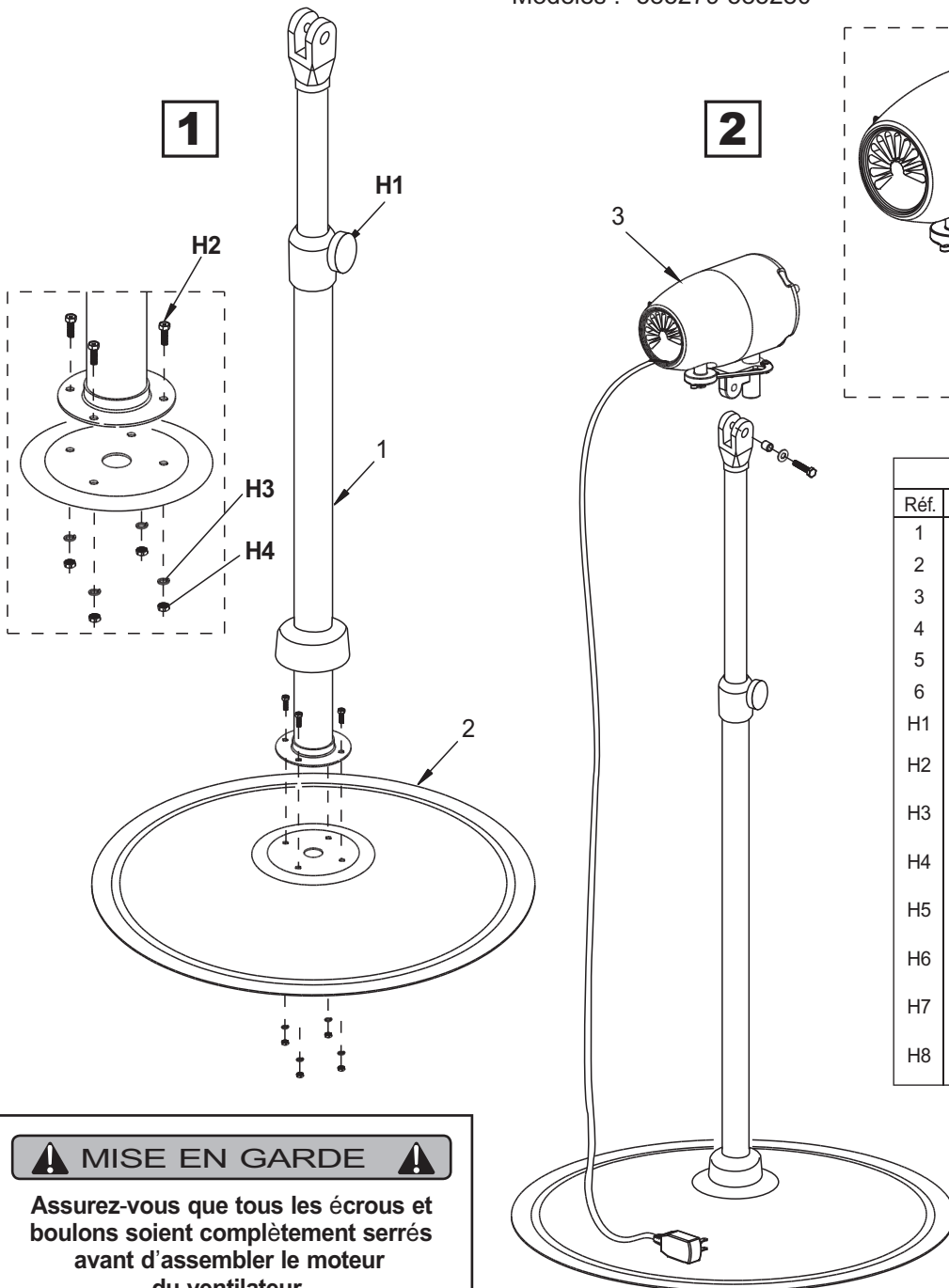

CONTENU		
Réf.	Qté.	Description
1	1	Poteau
2	1	Plaque de base
3	1	Moteur du ventilateur
4	1	Carénage arrière
5	1	Pale de ventilateur
6	1	Recouvrement du carénage
H1	1	Bouton de réglage M6 x 1.0.....
H2	8	Tornillo Hexagonal Lg. M6 x 1.0 x 18mm
H3	8	Rondelle élastique.....
H4	4	Écrou hexagonal M6 x 1.0mm ...
H5	1	Bague
H6	1	Rondelle plate
H7	1	Tornillo Hexagonal Lg..... M10 x 1.5 x50mm
H8	1	Clé Allen 4 mm.....

Ventilateur industriel sur pied

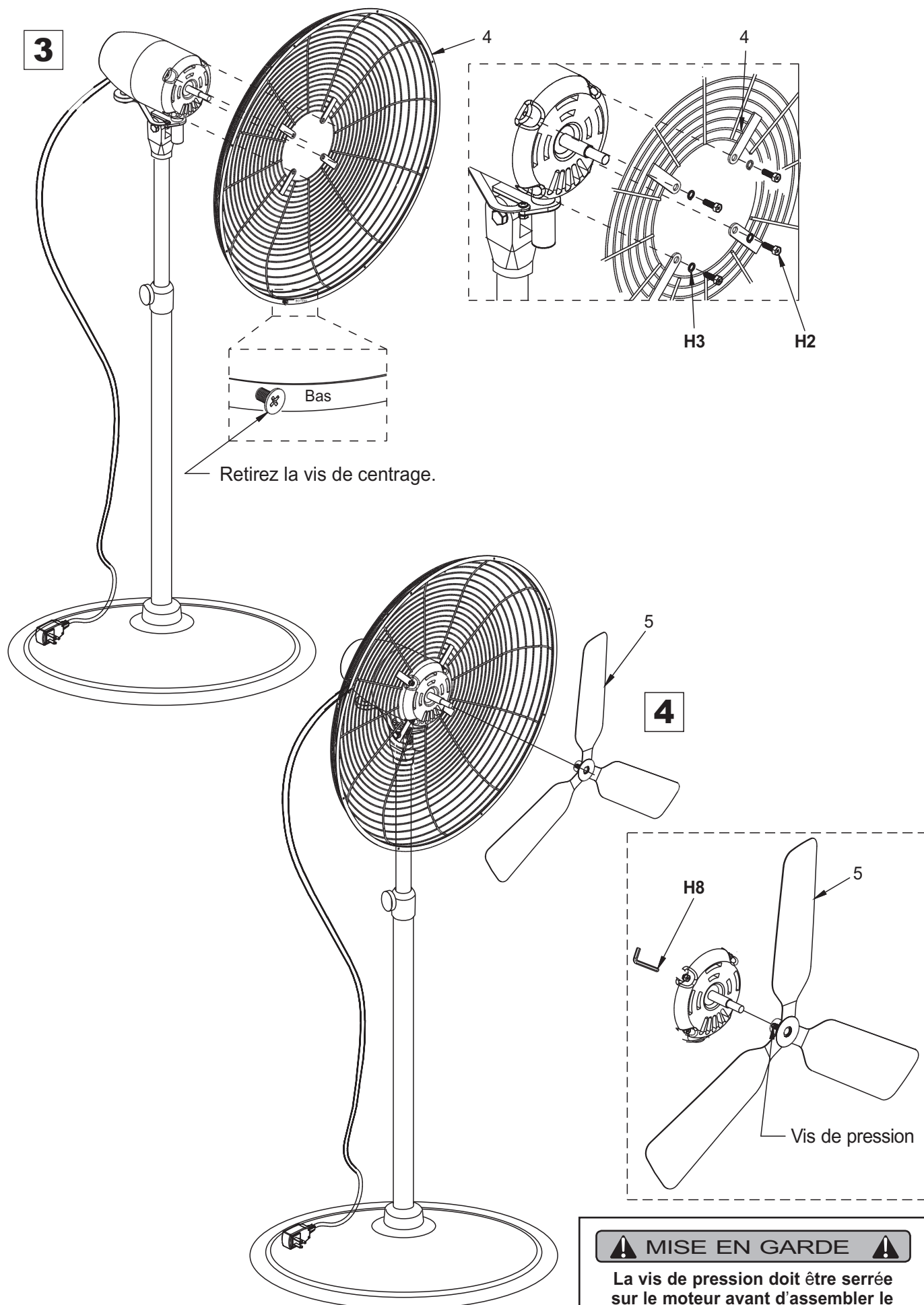

5

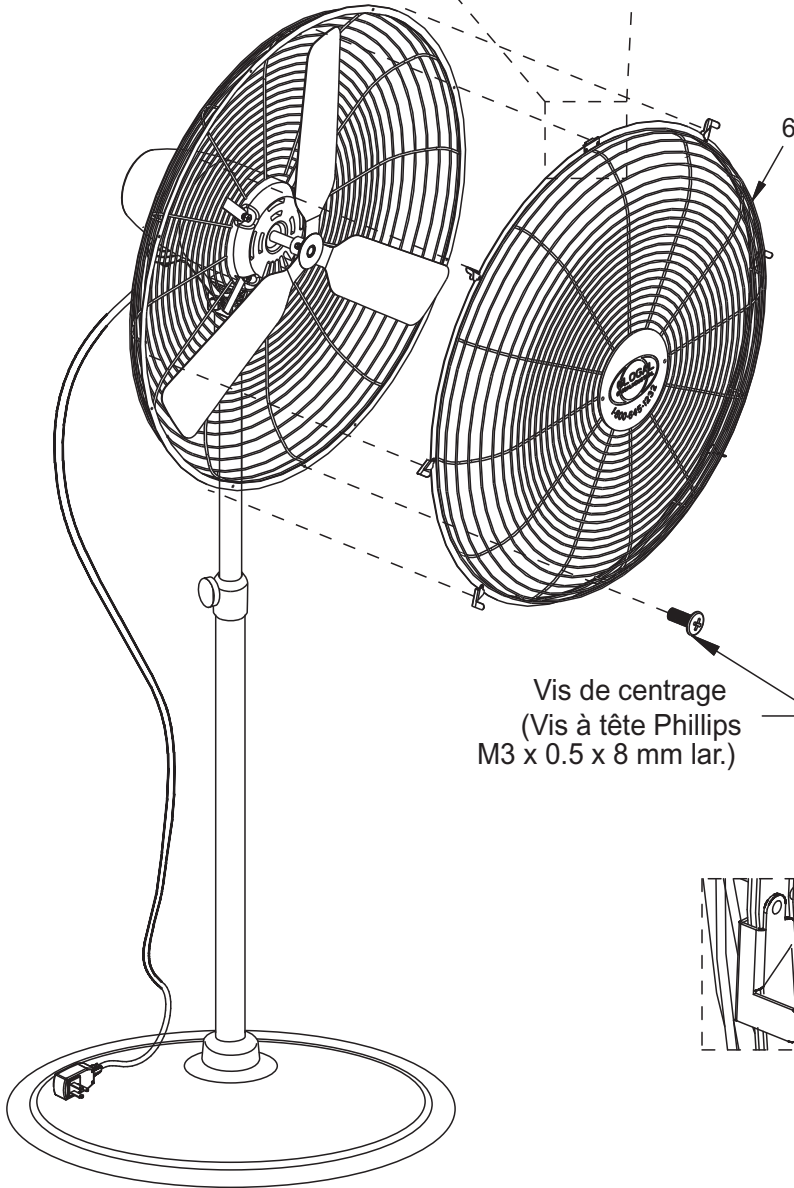
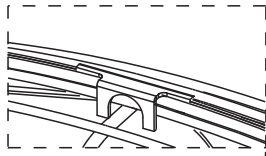

Vis de centrage
(Vis à tête Phillips
M3 x 0.5 x 8 mm lar.)



6

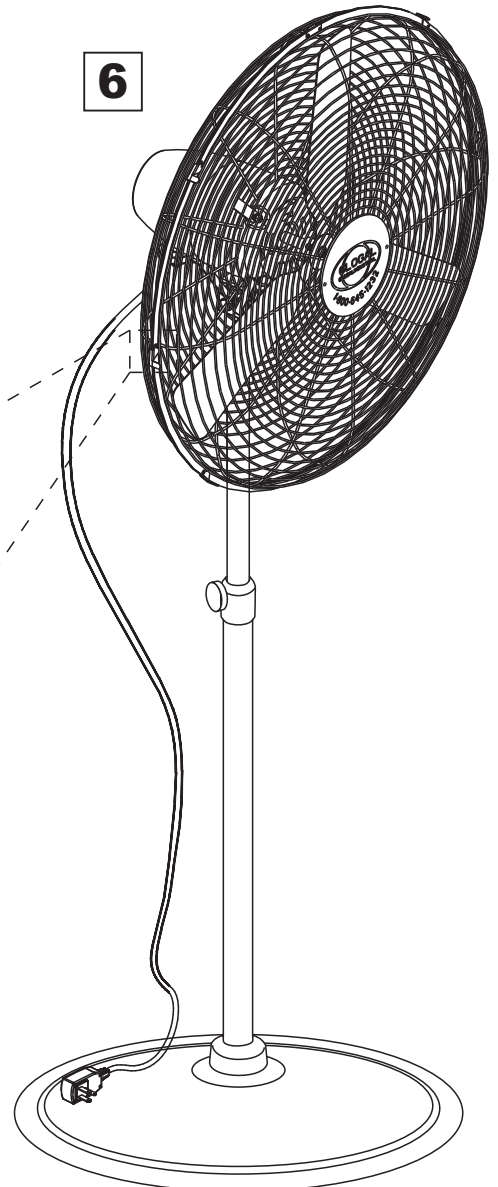

⚠ MISE EN GARDE ⚠

Débranchez avant l'ajustement.

POUR OSCILLER

Vis à épaulement Phillips M6 x 1.0

Osciller

Fixe

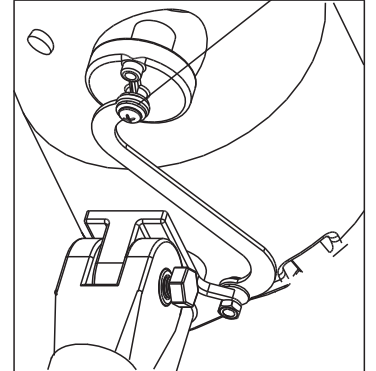
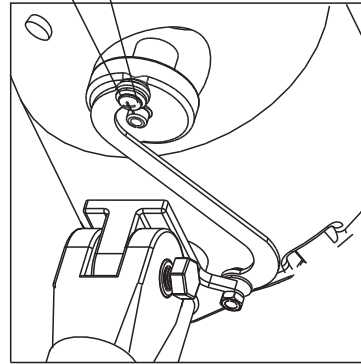

7

Boulon de réglage de l'angle

Bouton de réglage de la hauteur

Vis à tête cylindrique
Phillips M5 x 0.8 x 8 mm

Sélecteur de
vitesse

Pince du cordon d'alimentation

Cordon
d'alimentation