



TB & SB Series Drill Presses

OWNERS MANUAL

BENCH AND FLOOR DRILL PRESS

TB-16 Series & SB-16-25-32-Series

FOR YOUR OWN SAFETY AND
OPTIMUM OPERATION READ
INSTRUCTION MANUAL BEFORE
OPERATING DRILL PRESS
RETAIN THIS MANUAL FOR
FURTHER REFERENCE.



MODEL TB-16



MODEL SB-16-25-32

TABLE OF CONTENTS

• Model specifications	page 1
• Electrical diagram	page 1
• Voltage protection recommendations	page 1
• Drill press installation	page 2
• Safety points	page 3
• Power warning	page 4
• General safety instructions	page 4-6
• Voltage warning and grounding instructions	page 7
• Operation and set-up instructions	page 9 –10
• Tooling removal	page 11
• Work holding and machine maintenance	page 11
• Speed adjustment and belt tensioning	page 12
• Proper drill speeds for materials and bit diameter	page 13
• Dake safety features	page 13
• Exploded diagram TB / SB 16	page 14
• Parts list TB / SB 16	page 15
• Exploded diagram SB 25 / 32	page 16
• Parts list SB 25 / 32	page 17
• Trouble shooting matrix	page 18

MODEL AND SPECIFICATIONS

Machine Specifications:	Model TB-16	Model SB-16	Model SB-25	Model SB-32
Drill Type	Bench	Floor	Floor	Floor
Max. Drill Capacity	5/8"	5/8"	1"	1-1/4"
Spindle Taper	MT2	MT2	MT3	MT4
Spindle Travel	3-1/8"	3-1/8"	5"	5-1/4"
Max. Work Diameter	14-1/8"	14-1/8"	18"	18"
Speeds (Step Pulley)	9	9	9	9
Spindle Speed Range	240-3400	240-3400	270-2000	270-2290
Column Diameter	3-1/8"	3-1/8"	3-5/8"	4"
Table	11-3/4 x 11-3/4"	11-3/4 x 11-3/4"	14 x 14"	15-3/4 x 15-3/4"
Base	17-3/4 x 12-1/8"	19-1/2 x 12-1/2"	23-1/2 x 15"	23-1/2 x 15"
Spindle to Table	16-1/2"	28-1/4"	28-1/4"	26-1/4"
Spindle to Base	25-1/2"	49"	49-1/8"	50"
Motor	1/2 HP	1/2 HP	1 HP	2 HP
Electrics	CE	CE	CE	CE
Voltage	120 Volt	120 Volt	220 V – 3 PH	220 V – 3 PH
Overall Height	42-1/2"	64"	71"	71"
Weight	155 lbs.	210 lbs.	397 lbs.	463 lbs.

ELECTRICAL DIAGRAMS

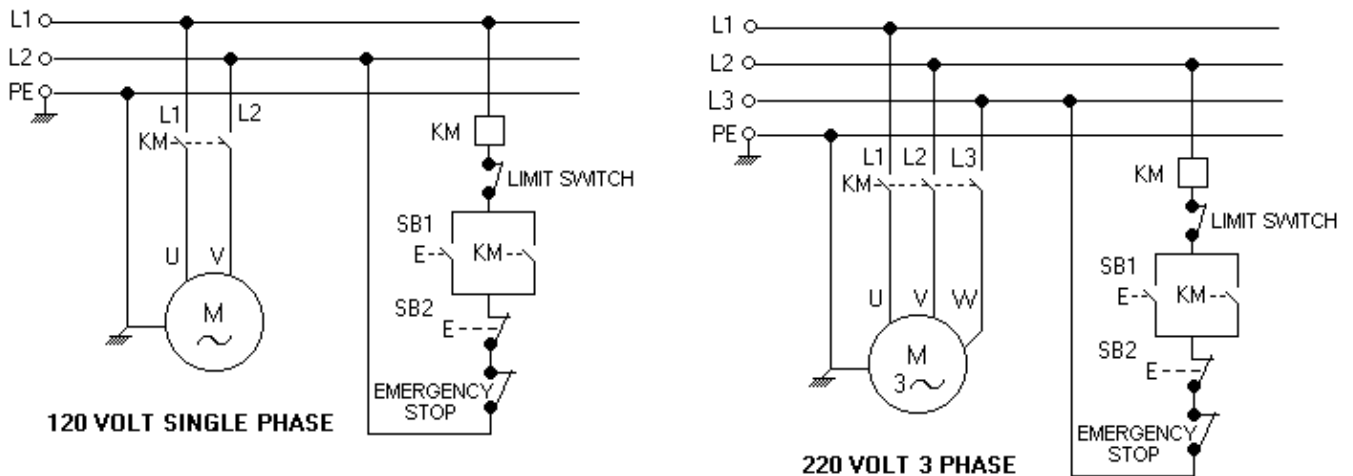

CAUTION

20 AMP circuit breaker is recommended for the TB-16 and SB-16 models.

30 AMP circuit breaker is recommended for the SB-25 110 volt model.

1. UNCRATING AND INSTALLATION

INSTALLATION OF DRILL PRESS <u>MACHINE IS TOP HEAVY!</u>	 CAUTION
<ol style="list-style-type: none">1. Location of the drill press should be in a well lit area with correct power supply and that will not interfere with other machines or operations.2. Carefully uncrate machine from crate. Inspect all packing as not to throw out any parts or manuals.3. When transporting the machine please use caution. If using a sling have someone steady the machine while transporting it.4. Install your drill press on a sturdy level floor surface, or work bench. (TB-16) The machine <u>must</u> be anchored to the floor or workbench securely. Machine is top heavy.5. Connect appropriate power to the machine. Make sure circuit breakers are suitable for the machine. Consult local codes for proper installation of machine. Always route power cables in a safe manner away from traffic areas, damp areas, heat and moving parts.6. After installing the drill press, use the kerosene or degreasing product to clean off the anti-rust oil which was applied at the factory. Then wipe machined surfaces with a light coating of lubricant oil. (Way oil)7. Read rest of the owners manual before operating this machine. Review and understand all safety instructions.	

- **SAFETY POINTS**

BEFORE USE, ALL SAFETY POINTS MUST BE READ AND UNDERSTOOD!

Before the DRILL PRESS is used, the instruction manual with this machine must be read and understood. This manual offers safe operation instructions. Offered below are safety instructions designed for the drill press and general safety instructions that apply to most machinery.



Operation of the drill press incorrectly, or in a dangerous fashion can result in serious injury or death.



Operation of the drill press incorrectly, or in a dangerous fashion can result in damage to machine or it's components and to the cutting tool.

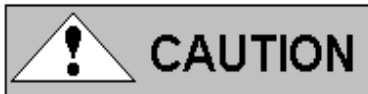

Instructions for safe drill press use.



Intend use :

The DRILL PRESS is designed to for drilling or boring operations. Caution is required when operating the drill press because it can be dangerous due to the high spindle rotation speed. Operation hazards such as entanglement, shearing, ejection partsetc. Guards such as pulley cover and chuck guard must in place and working condition to prevent any hazard.

Please think about the safety warnings in the instruction manual before operating the machine.

2. FOR SAFE OPERATION

For your own safety read the instruction manual before operating DRILL PRESS.

 DANGER	
HIGH VOLTAGE TURN OFF THE POWER BEFORE SERVICE	
<ol style="list-style-type: none">1. SWITCH the POWER OFF before setting, inspecting lubricating, cleaning or changing the drill bit.2. Always wear the eye protection.3. Do not wear gloves, necktie, necklaces, rings or loose clothing.4. To clamp work piece or brace against column to prevent material rotation.5. Use recommended speed for drill bit, and work piece material.	

3. GENERAL SAFETY INSTRUCTION

 DANGER	GENERAL SAFETY INSTRUCTION
<ol style="list-style-type: none">1. Keep guards in place and in working order.2. Remove adjusting key and wrenches. Be in the habit of checking to see that keys and adjusting wrenches are removed from tool before turning it on.3. Keep work area clean. Cluttered areas and benches invite accidents.4. Do not use in dangerous environment. Do not use power tools in damp or wet locations or expose them to rain. Keep work area well lighted.5. All visitors should be kept safe distance from work area.6. Make workshop kid proof with padlocks, master switches, or by removing starter key.7. Do not force tool. It will do the job better and safer at the rate for which it was not designed.	



DANGER

**GENERAL SAFETY
INSTRUCTION
Continued**

8. Use the right tool. Do not force the tool, or use the machine to do a job for which it was not designed.
9. Wear proper apparel. No loose clothing, gloves, necktie, rings or other jewelry to get caught in moving parts. Non-slip footwear is recommended. Wear protective hair covering to contain long hair.
10. Always use safety glasses. Also use face or dust mask if cutting operation is dusty.
11. Secure work. Use clamps or a vise to hold work. Do not hold part with hands.
12. Do not overreach. Keep proper footing and balance at all times.
13. Maintain tools with care. Keep tools sharp and clean for best and safest performance.
14. Disconnect drill press from power before servicing, when changing accessories such as bits, cutter ...etc.
15. Reduce the risk of unintentional starting. Make sure switch is in off position before plugging in.
16. Use recommended accessories. Consult the owner's manual for recommended accessories. The use of improper accessories may cause risk of injury to persons.
17. Never stand on machine, or serious injury could occur.
18. Check for damaged parts. Before further use of the machine, a guard or other part that is damaged should be replaced or repaired. Carefully check to determine that it will operate properly and perform its intended function. Check for alignment of moving parts, binding of moving parts., breakage of parts or mountings and any other conditions that affect its operation.
19. Never leave tool running unattended. Turn power off. Do not leave machine until it comes to a complete stop.

4. SAFETY INSTRUCTIONS FOR DRILL PRESS

 CAUTION	SAFETY INSTRUCTIONS FOR DRILL PRESS
<ol style="list-style-type: none">1. Wear eye protection.2. Do not wear gloves, necktie, rings or loose clothing.3. Clamp work piece or brace against column to prevent rotation.4. Use recommended speed for drill bits and sizes and work piece materials.5. Be sure drill bit or cutter tool is securely locked in the chuck.6. Be sure chuck key is removed from the chuck before turning on power.7. Adjust the table or depth stop to avoid drilling into the table, shut off the power. Remove the drill bit or cutting tool, and clean the table before leaving the machine.8. Do not operate until it is completely assembled and installed according to the instructions.9. If any port of your drill press is malfunctioning or has been damaged or broken, do not operate until the part is properly repaired or replaced.10. Never place your fingers in a position where they could contact the drill or other cutting tool if the work piece should unexpectedly shift.11. Never use your hand to hold on the object while drilling, always clamp the object tight on the working table.12. Never perform any operation by moving the head or table with respect to one another. Do not switch machine on or start any operation before checking that the head and table lock handle are clamped tight to column, and head and table support collars are correctly positioned.13. Before switching the power on be sure the belt cover is down and the bit is installed properly in the chuck.14. Lockout the motor switch when leaving the drill press. Don't perform layout, assembly or setup work on the table while the cutting tools rotating.	

5. VOLTAGE WARNING

 WARNING	VOLTAGE WARNING
<ol style="list-style-type: none">1. Before connecting the machine to a power source (receptacle, outlet... etc.) Know your incoming voltage supply. (220, 208 etc.)2. A power source with voltage greater than that specified for the machine can result in serious injury to the user, and machine damage.3. Using a power source with voltage less than that of the machines rating can damage the motor and other components.4. If you are unsure of the voltage rating do not use the machine.	

6. GROUNDING INSTRUCTION

<ol style="list-style-type: none">1. In the event of a malfunction or breakdown, grounding provides a path of least resistance for electric current to reduce the risk of electric shock. This machine is equipped with an electric cord having an equipment grounding conductor. The proper plug must be used with a matching outlet that it is properly installed and grounded in accordance with all local codes and ordinances.2. For 120 volt models do not modify the plug provided. If it will not fit the outlet, have the proper outlet installed by a qualified electrician.3. Improper connection of the equipment grounding can result in a risk of electric shock. The conductor with insulation having an outer surface that is green with yellow stripes is equipment grounding conductor. If repair or replacement of the electric cord or plug is necessary, do not connect the equipment grounding conductor to a live terminal.4. Check with a qualified electrician or serviceman if the grounding instructions are not completely understood, or if in doubt as whether the machine is properly grounded.5. It is <u>not</u> recommended to use an extension cord on this machine. If one must be used, use only a grounded cord of proper size for machine and length of run needed.6. Repair or replace damaged or worn cords immediately.
--

7. OPERATION (PROCEDURE)

 **DANGER:** To show greater detail chuck guard is in the open position in photos. **CHUCK GUARD MUST IN PLACE DURING OPERATION!**



Table lock

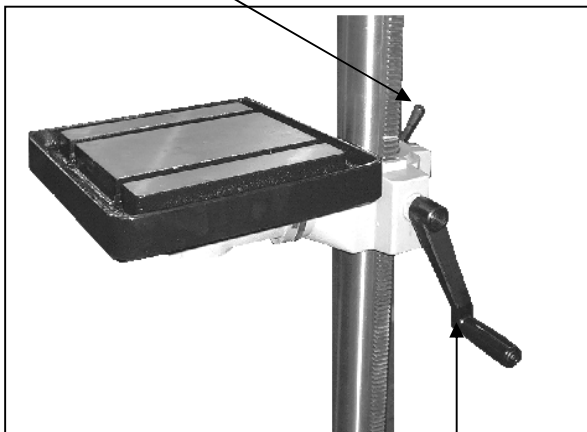

Drill / Chuck Installation:

 **DANGER:**
**POWER MUST BE OFF BEFORE
MAKING ANY ADJUSTMENTS!**

TURN POWER OFF! Before inserting drill bits, chucks or arbors, always clean out spindle hole and taper hole with a clean cloth.

Open chuck jaws completely by turning attached chuck key counter-clockwise until the jaws are fully opened.

To install the chuck to the arbor tightly, slide the chuck into the taper forcing it into the spindle with by hand. Place a block of wood on the table then lower the spindle to make contact with the wood and press the chuck tightly into the spindles taper.

Install a taper shaft drill bit into the taper the same way as you would the chuck. If an adaptor is used it must fit the taper correctly and the bit must fit snug in the adaptor.

Table height adjustment:

Table height adjustment is accomplished by loosening the clamp bolt then adjusting the table with the bracket handle to desired height. After table is at working height, retighten the clamp bolt securely.

Note: Keep table adjustment rack clean from debris. Never attempt to move table with clamp bolt tightened.

Table handle

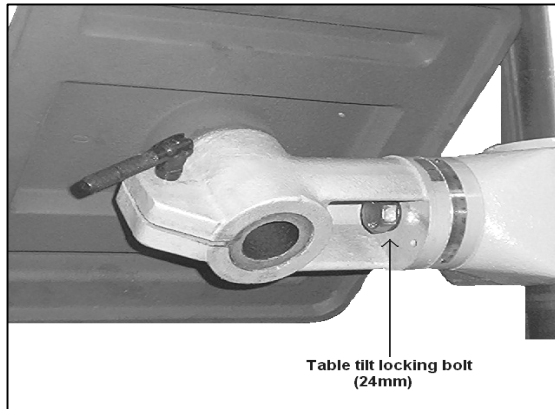
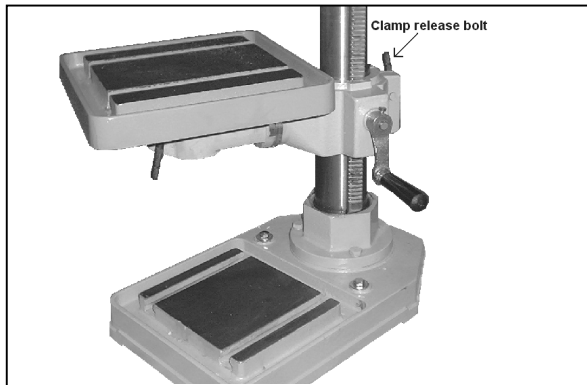

Table tilting adjustment:

Using an adjustable or box wrench loosen table level lock bolt. Carefully tilt the table to the degree needed, as read on the angle index scale located on the table rotation point. Retighten nut securely.

Note: Never tilt table if any material or fixturing is on it. Only make adjustments when table is free of loose articles.

Table swing adjustment:



To swing the table up to 360 degrees, loosen the clamp release bolt and swing table to the desired position. After the table is in the correct position tighten clamp release bolt securely.

Note: Never swing table if any material or fixturing is on it. Only make adjustments when table is free of loose articles.

Feed depth adjustment:

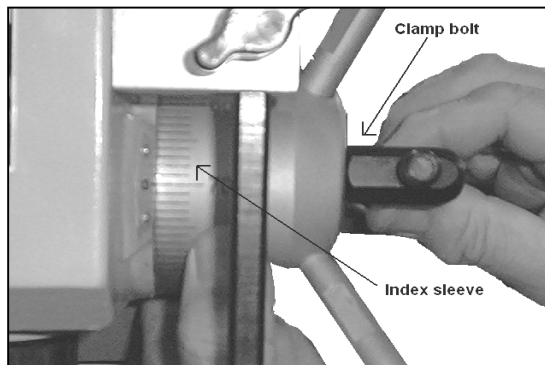

Setting the feed depth adjustment is done by loosening the clamp bolt on the spindle depth index sleeve and rotating it to the desired depth.

Retighten clamp bolt securely.

Note: Never make this or other adjustments when machine is running.



DANGER: TURN POWER OFF!
Wait until machine has come to a complete stop before proceeding with speed change!

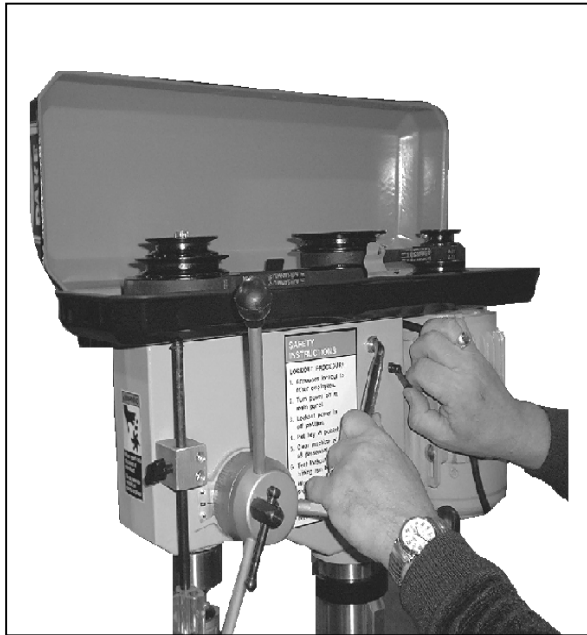

Speed adjustment:

Open the pulley cover to expose the pulleys and drive belts. Loosen the belt tension lock handles. Choose the proper speed for the drilling operation. Move the belt to the correct step of the pulleys for the desired speed. (See diagram on page 12) Push the motor backwards until proper belt tension is applied. (1/2" deflection as shown below speed selection chart in this manual) Retighten belt tension lock handle. **NOTE:** If center pulley bracket does not move freely, loosen spring loaded bolts 1/2 - 3/4 turns.



Installation of drill bits in the chuck:

A drill bit with a shaft of at least 1" long should be used to allow correct chuck jaw contact. If shaft length is under 1" do not insert bit as far into the chuck where it allows jaw contact with drill flutes. Center drill bit into the chuck and tighten the chuck securely with the chuck key. **Note:** Always use sharp, straight bits. Never use bits with turned down shafts. Never exceed the maximum diameter bit size for the machine. Always wear appropriate clothing while operating the drill press. All guards and interlocks must be in place when operating the machine.

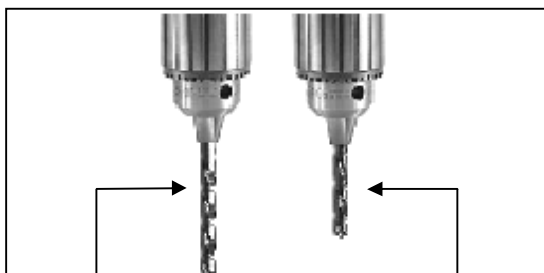

Correct: Jaws
contact drill shaft

Incorrect: Jaws
contact drill flutes

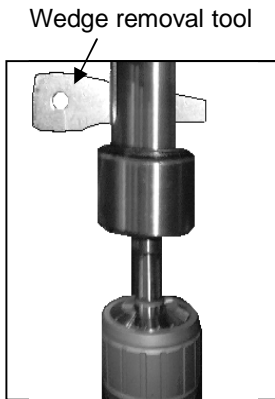

Tooling removal:

Before removing the chuck or bit from the machine, be sure the spindle has come to a complete stop and power is off. If needed rotate spindle by hand to align the spindle and quill openings. Insert the wedge removal tool, while supporting the tooling tap the wedge to remove the tooling.

Work holding:

When drilling directly on table surface, it is recommended that a piece of wood or plywood be clamped securely to table under the work piece. This will minimize splintering or burring as drill breaks through work. It will help minimize drill bit and table damage. Clamp work piece to the table when ever possible. Table has "T" slots that allow for many different clamping configurations. When part cannot be affixed to the table a drill vise that is bolted to the table must be used to hold work piece safely.

8. MAINTENANCE OF MACHINE

MAINTENANCE



CAUTION

1. On a regular basis blow out any dust that may accumulate inside the motor. (Frequency depends on environment the machine is in)
2. A coat of automotive wax applied to the table and column will help to keep the surface clean.
3. If the power cord is worn or cut, or damaged in any way, have it replaced immediately.
4. All of the ball bearings are packed with grease at the factory. They require no further lubrication.
5. Periodically lubricate the gear and rack table elevation mechanism, the spindle splines and the rack (teeth on the quill).
6. After each use the machine should be cleaned. Weekly lubrication of all sliding or moving parts with light weight or way oil is recommended. For your own safety, turn switch "OFF" and remove plug from power source outlet before maintaining or

SPEED ADJUSTMENT

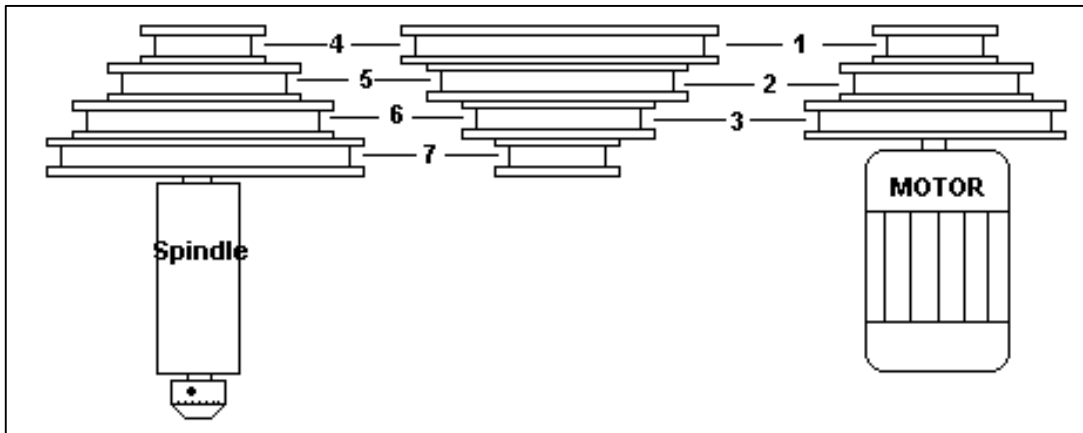

MODEL →	TB & SB 16	SB 25	SB 32
PULLEY STEPS	RPMs	RPMs	RPMs
1 - 7	= 240 rpm	= 270 rpm	= 270 rpm
1 - 6	= 420 rpm	= 400 rpm	= 410 rpm
2 - 7	= 450 rpm	= 450 rpm	= 450 rpm
1 - 5	= 660 rpm	= 550 rpm	= 600 rpm
2 - 6	= 760 rpm	= 660 rpm	= 690 rpm
3 - 7	= 780 rpm	= 720 rpm	= 720 rpm
2 - 4	= 1980 rpm	= 1270 rpm	= 1410 rpm
3 - 5	= 2100 rpm	= 1460 rpm	= 1620 rpm
3 - 4	= 3400 rpm	= 2000 rpm	= 2290 rpm

BELT TENSION ADJUSTMENT

Proper belt tension is approx. 10 lbs. of pressure, or deflection of about 1/2 "

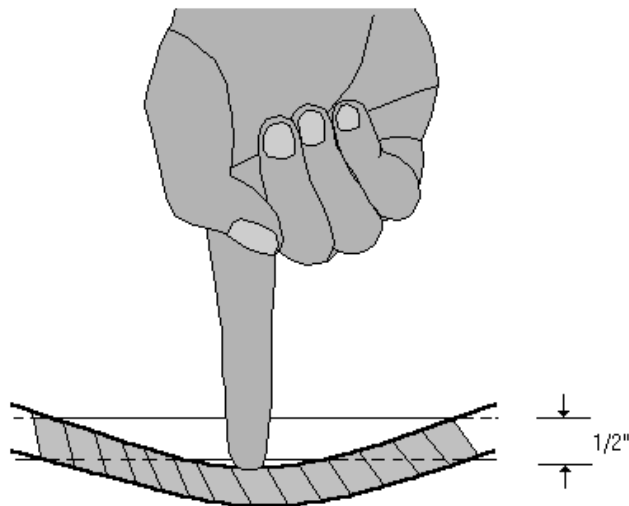

The proper drill speed for a given drill bit size is as on following table :

Material Type	Cast Steel	Tool Steel	Cast Iron	Mild Steel	Alum. & Copper	
	SURFACE FEET PER MINUTE					
Drill Dia.	s.f.m.	s.f.m.	s.f.m.	s.f.m.	s.f.m.	
	40	60	80	100	200	
Inch	REVOLUTIONS PER MINUTE					
TB-16 & SB-16	1/16	2,445	3,665	4,890	6,110	12,225
	1/8	1,220	1,835	2,445	3,055	6,110
	3/16	815	1,220	1,630	2,035	4,075
	1/4	610	915	1,220	1,530	3,055
	5/16	490	735	980	1,220	2,445
	3/8	405	610	815	1,020	2,035
	7/16	350	525	700	870	1745
	1/2	305	460	610	765	1,530
SB-25	5/8	245	365	490	610	1,220
	3/4	205	305	405	510	1,020
	7/8	174	261	348	435	762
SB-32	1	153	229	306	382	668
	1-1/8	136	204	272	340	595
	1-1/4	122	167	244	306	535

SAFETY FEATURES OF DAKE DRILL PRESSES

CHUCK / CHIP GUARD

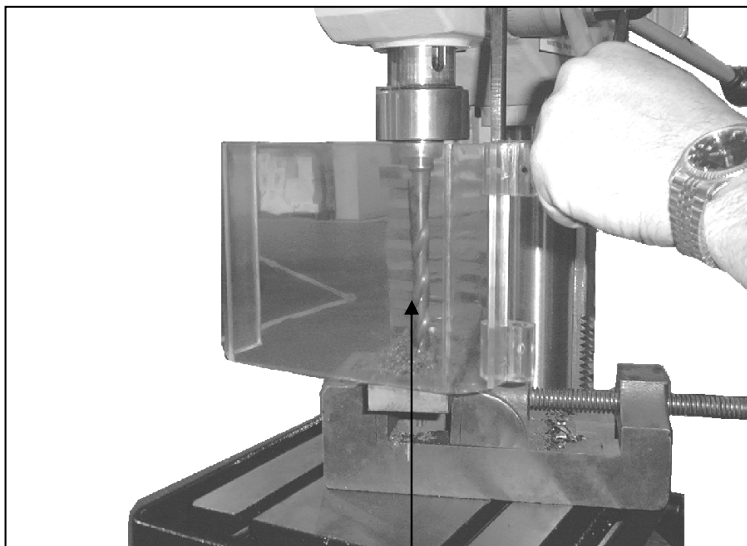

FOR OPERATOR SAFETY, ALWAYS USE PROPERLY

CE CERTIFIED ELECTRONICS

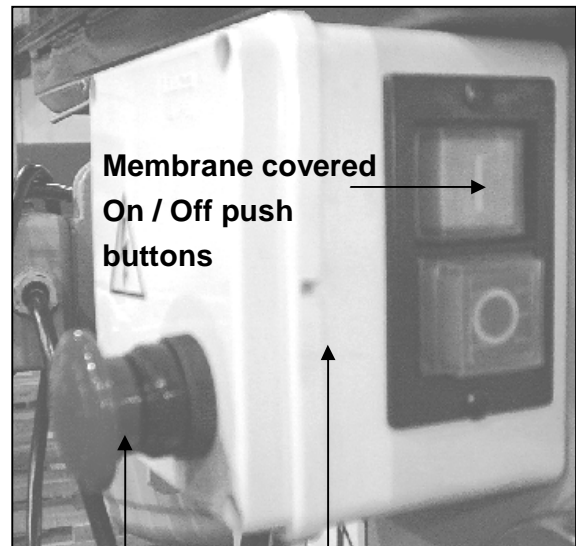

Low voltage, thermo

protection
POSITIONED CHUCK GUARD.

Emergency stop button. Belt cover interlock

DAKE TB / SB 16

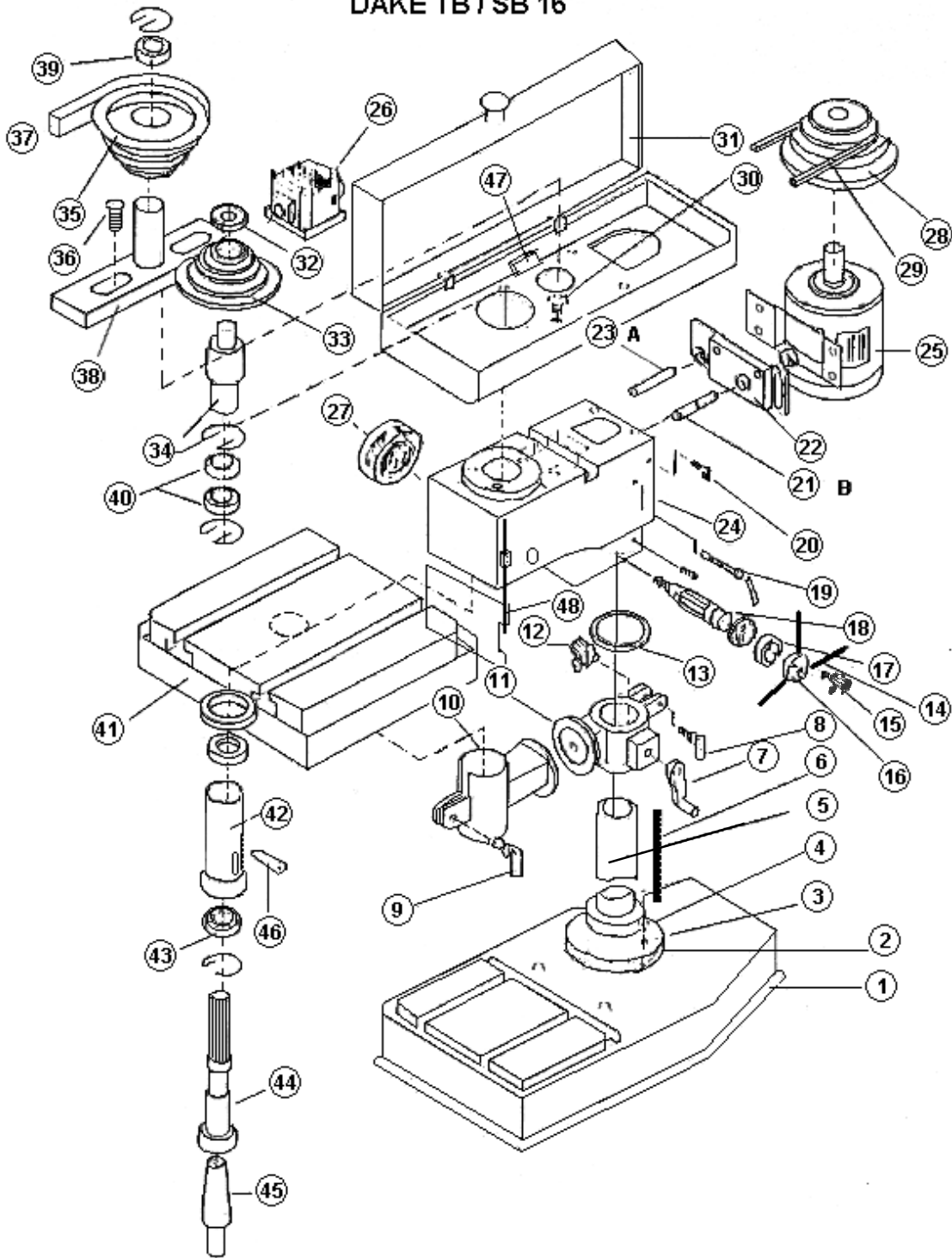

PARTS LIST for TB-16 / SB-16

Item No.	Description	TB-16	SB-16	Item No.	Description	TB-16	SB-16
1	Base TB-16	301002	301001	25	Motor	300993	300993
2	Flange	301003	301004	26	Switch	301024	301024
3	Spring Washer (4x)	13mm	13mm	27	Spring & Cap Base	301025	301025
4	Screw	300999	300999	28	Motor Pulley	301026	301026
5	Column	301005	301006	29	Belt A28	301027	301027
6	Rack	301007	301007	30	Screw (4x)	300998	300998
7	Handle	301008	301008	31	Pulley Cover	301028	301028
8	Clamp Bolt	301009	301009	32	Insert Pulley Nut	301029	301029
9	Clamp Bolt	301010	301010	33	Spindle Pulley	301030	301030
10	Table Arm	301011	301011	34	Insert Pulley Shaft	301031	301031
11	Table Bracket	301012	301012	35	Middle Pulley	301032	301032
12	Worm	301056	301056	36	Screw & Spring (2x)	301033	301033
13	Collar	301013	301013	37	Belt A23	301093	301093
14	Feed Handle (3x)	301014	301014	38	Middle Pulley Shaft	301034	301034
15	Lock Handle	301070	301070	39	Bearing 6203Z	300987	300987
15a	Lock Screw	302818	302818				
16	Feed Head	301016	301016	40	Bearing 6203Z	300987	300987
17	Spindle Scale	301017	301017	41	Table	301035	301035
18	Feed Shaft	301018	301018	42	Quill 1.85"	301036	301036
19	Belt Adjust Handle	301019	301019	43	Bearing 6003Z	300988	300988
20	Wing Bolt	301077	301077	44	Spindle	301037	301037
21	Road - B	301022	301022	45	Arbor	301038	301038
22	Motor Plate	301021	301021	46	Wedge	301039	301039
23	Road - A	301020	301020	47	Belt Cover Interlock Switch	300992	300992
24	Head	301023	301023	48	Plexiglas Chuck Guard	300997	300997
				N/A	Chuck 13mm	301870	301870

DAKE SB 25 & 32

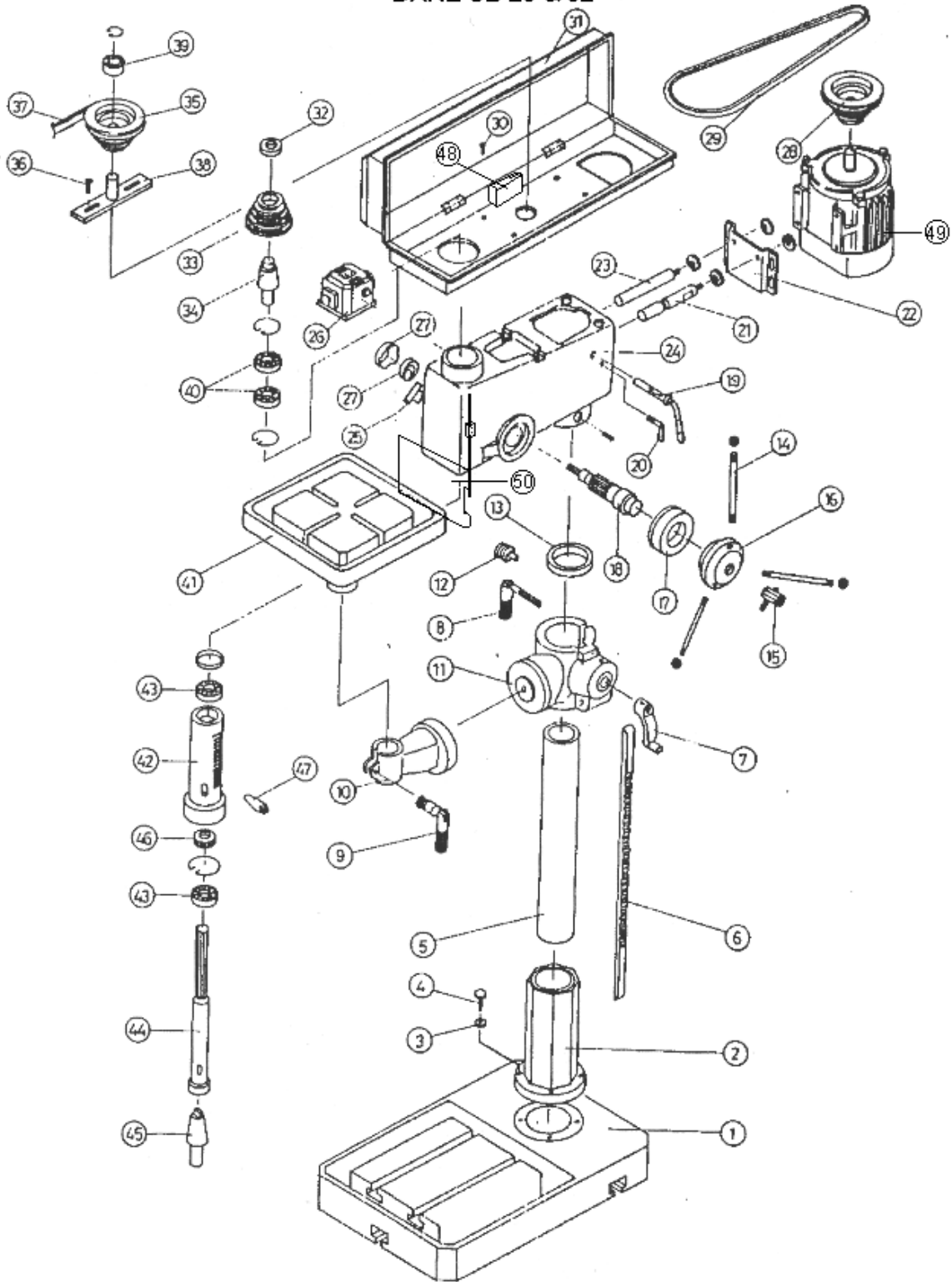

PARTS LIST for SB-25 / SB-32

Item No.	Description	SB-25	SB-32	Item No.	Description	SB-25	SB-32
1	Base	301040	301041	27	Spring & Cap	301063	301064
2	Flange	301042	301043	28	Motor Pulley	301065	301065
3	Spring Washer (4x)	13 mm	13 mm	29	Belt	301066	301066
4	Screw	300999	300999	30	Screw (4x)	300998	300998
5	Column	301044	301045	31	Pulley Cover	301067	301068
6	Rack	301047	301046	32	Insert Pulley Nut	301085	301086
7	Handle	301048	301048	33	Spindle Pulley	301088	301087
8	Clamp Bolt	301049	301049	34	Insert Pulley Shaft	302218	302217
9	Clamp Bolt	301051	301051	35	Middle Pulley	301089	301090
10	Table Arm	301052	301053	36	Screw & Spring (2x)	301092	301092
11	Table Bracket	301055	301054	37	Belt	301093	301093
12	Worm	301056	301056	38	Middle Pulley Shaft	301094	301094
13	Collar	301057	301058	39	Bearing 6203Z	300987	300987
14	Feed Handle (3x)	301059	301059	40	Bearing 6203Z	300987	300987
15	Lock Handle	301070	301070	41	Table	301095	301096
15 a	Lock Screw	302818	302818				
16	Feed Head	301069	301069	42	Quill 25 model 2.42" 32 model 2.98"	301098	301097
17	Spindle Scale	301071	301072	43	6025Z & 6206Z (SB-25) Bearing	300990	300990
18	Feed Shaft	301073	301074		6006Z & 6208Z (SB-32) Bearing	300989	300989
19	Belt Adjust Handle	301075	301076	44	Spindle	301099	301100
20	Wing Bolt	301077	301078	45	Arbor	301101	301102
21	Road - A	301079	301080	46	Seal	N/A	N/A
22	Motor Plate	301081	301081	47	Wedge	301104	301103
23	Road - B	301082	301083	48	Belt Cover Interlock Switch	300992	300992
24	Head	301060	301084	49	Motor	300996	300994
25	Spring Base	N/A	N/A	50	Plexiglas Chuck Guard	300995	300995
26	Switch	301061	301062	N/A	Chuck 16mm	301966	301966

