

Assembly Instructions	Instrucciones de Ensamblaje	Directives d'assemblage
Customer Service US: 1-800-645-2986	Servicio de atención al Cliente México: 01.800.681.6940	Service à la clientèle Canada: 888-645-2986

MOBILE WORKSTATION

Models 670060 670061 670062 670063

CONTENTS		
Ref.	Qty.	Description
1	1	Mobile Base
2	2	Caster/Brake
3	2	Plain Caster
4	1	Column
5	1	Mounting Bracket
6	1	Work surface
7	1	End Cap
8	1	Wire Guide

HARDWARE CONTENTS		
Ref.	Qty.	Description
A	4	M8 x 65mm Socket Screw
	4	Plain Washer
B	1	Bracket
	2	M6 x 10mm Socket Screw
C	1	6mm 5mm 4mm 3mm
D	1	17mm Wrench

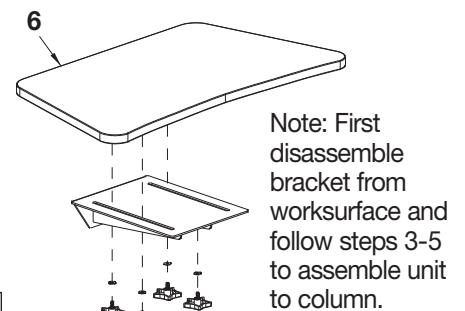
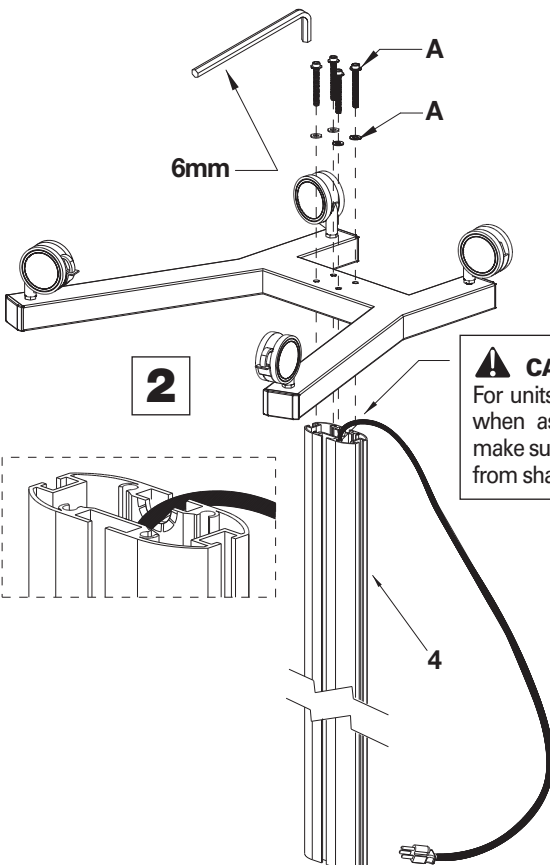
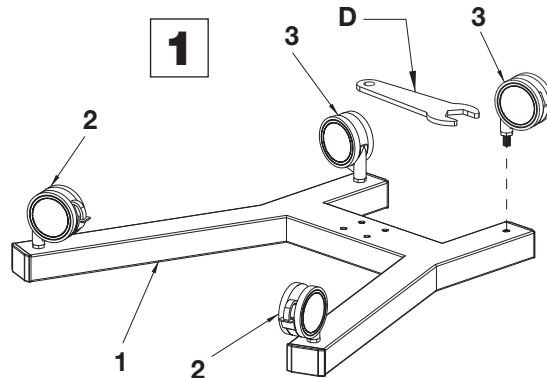
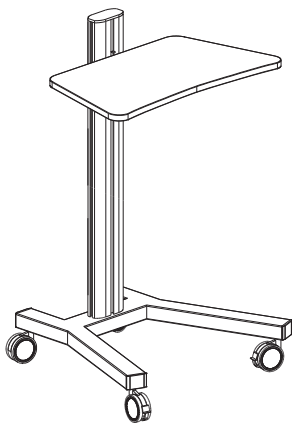

Note: Loosely attach adjustable height bracket to mounting bracket.

Mobile Workstation

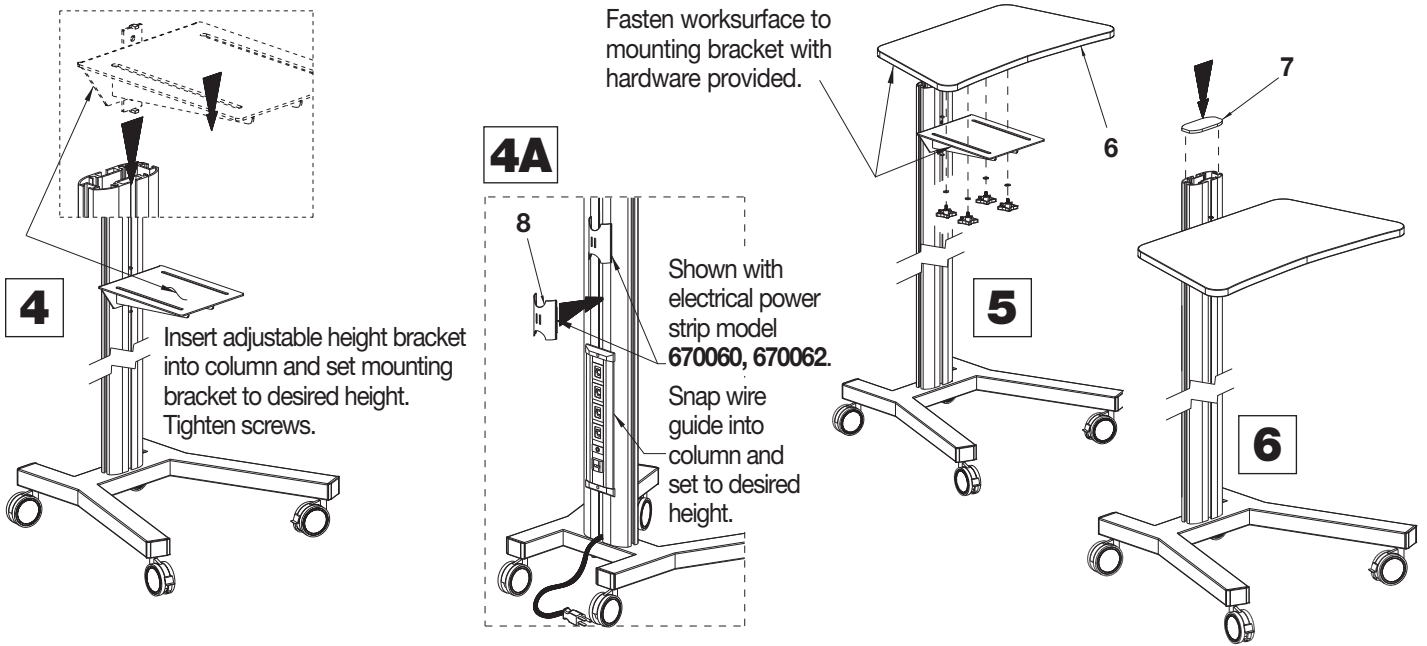

OPTIONAL ACCESSORY 670064 Monitor Mount

CONTENTS		
Ref.	Qty.	Description
1	1	Adjustable Height Bracket
2	1	Monitor Mount
3	2	End Cap

Note: Consult your monitor manual for the correct size screws to avoid damage.

HARDWARE CONTENTS					
Ref.	Qty.	Description	Ref.	Qty.	Description
	1	Front or Back Mounting Bracket			Use for attaching monitor to monitor mount 4 M4 x 15mm Socket Screw 4 M5 x 15mm Socket Screw 4 M6 x 15mm Socket Screw 4 4mm Plain Washer 4 5mm Plain Washer 4 6mm Plain Washer
A	2	8mm Plain Washer			
	2	M8 x 1.25 Knob	B		
	1	6mm			
	1	5mm			
	1	3mm			

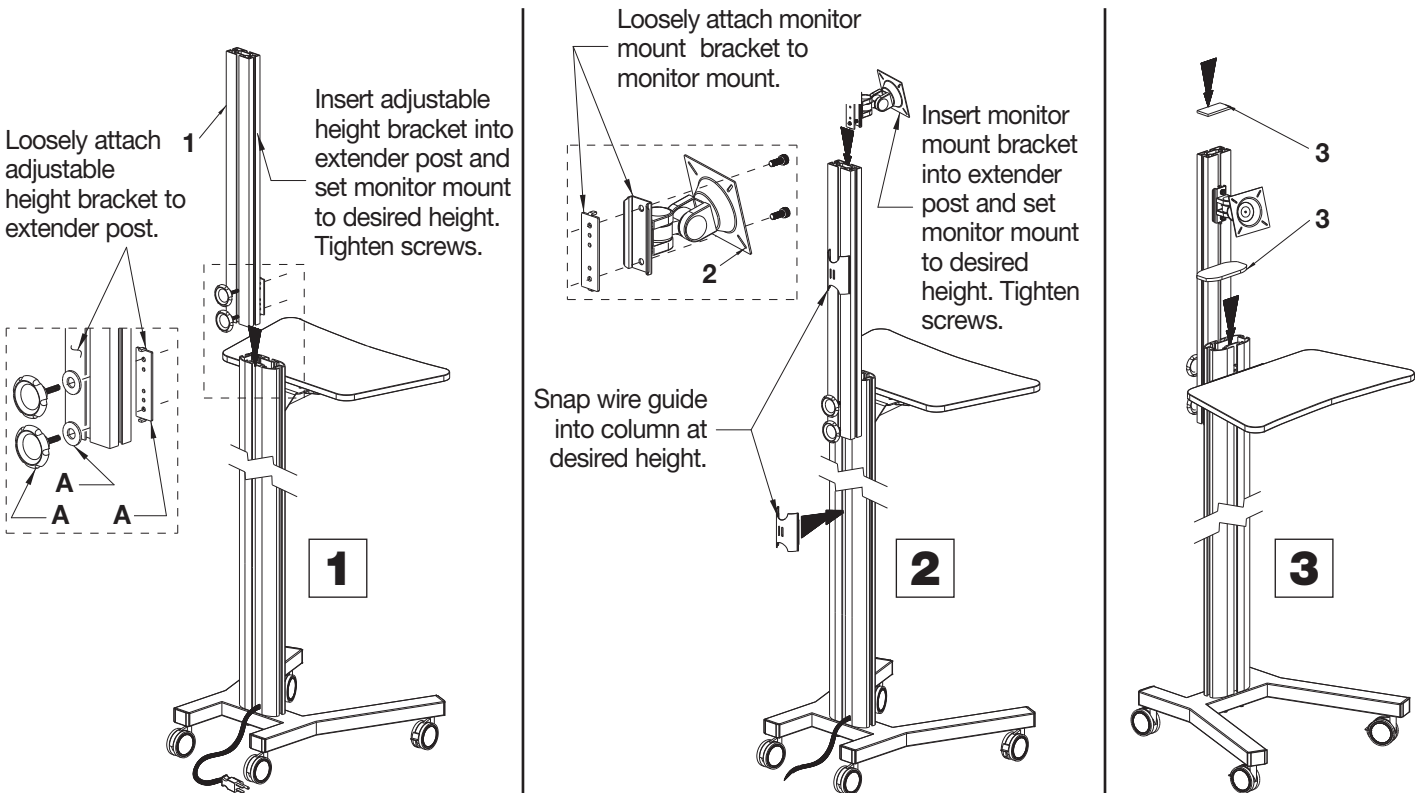

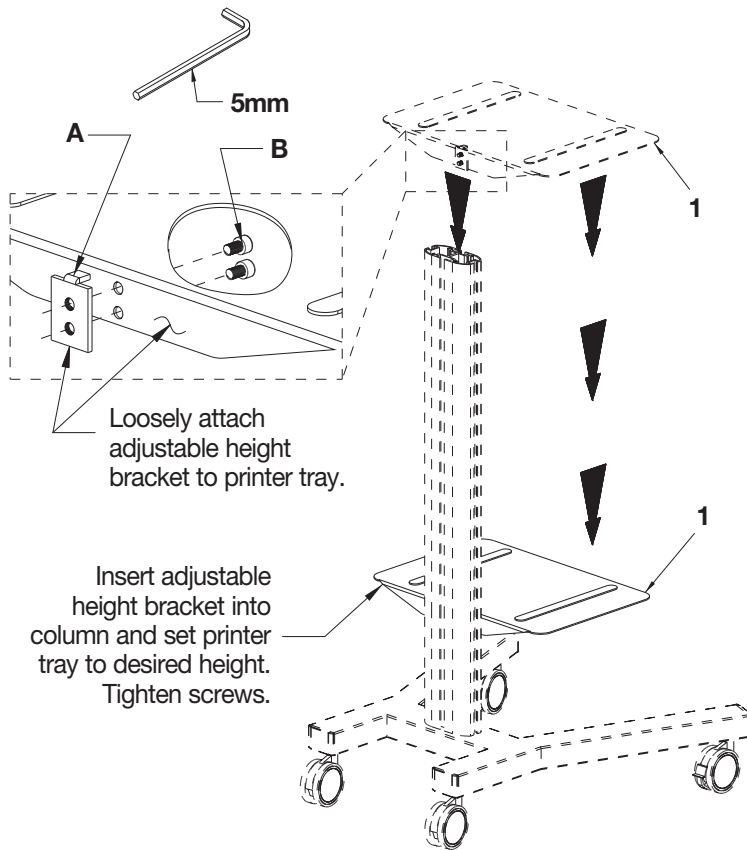

Mobile Workstation

OPTIONAL ACCESSORY 670066 Printer Tray



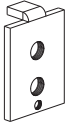

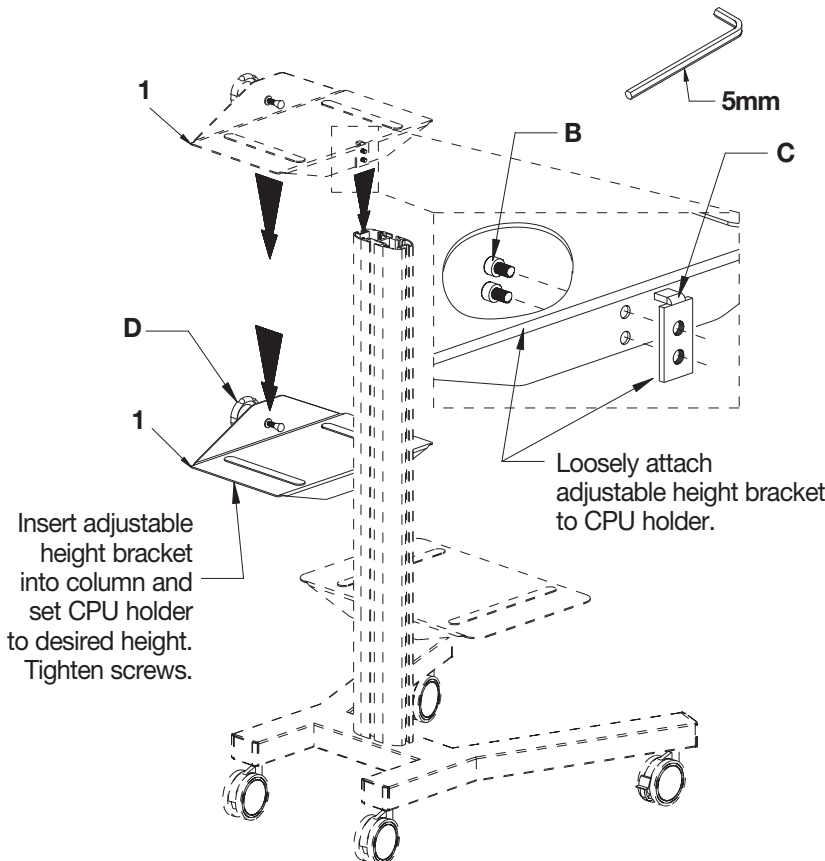

CONTENTS		
Ref.	Qty.	Description
1	1	Printer Tray

HARDWARE CONTENTS		
Ref.	Qty.	Description
A	1	Front or Back Mount Adjustable Height Bracket 
B	2	M6 x 10mm Socket Screw 
C	1	Side Mount Adjustable Height Bracket 

OPTIONAL ACCESSORY 670065 CPU Holder

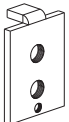

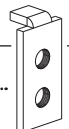
CONTENTS		
Ref.	Qty.	Description
1	1	CPU Holder



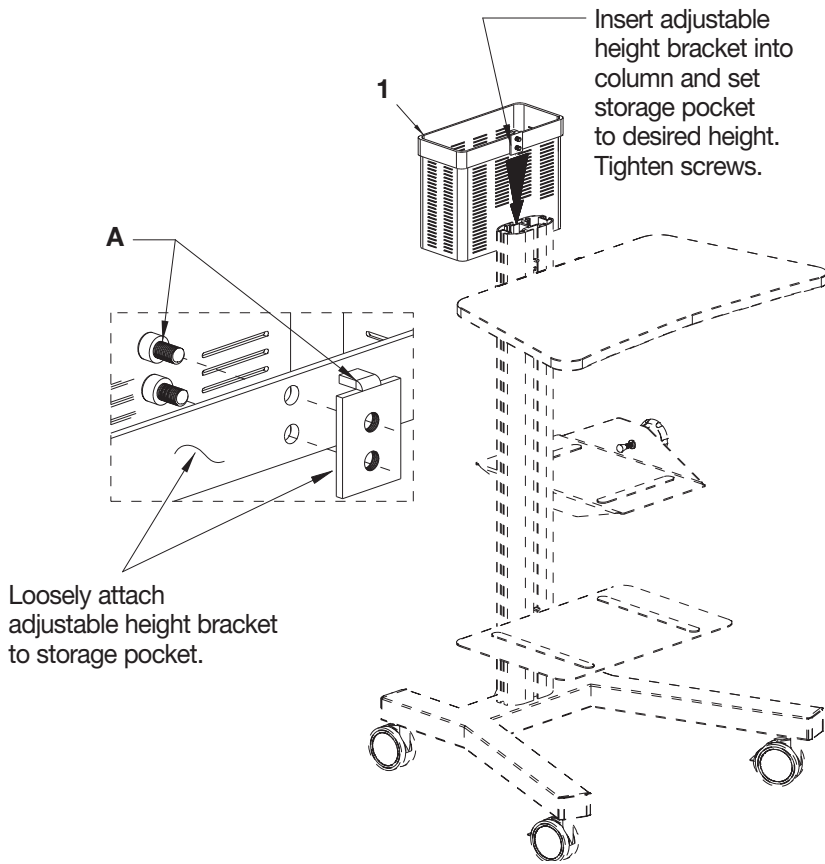

HARDWARE CONTENTS		
Ref.	Qty.	Description
A	1	Front or Back Mount Adjustable Height Bracket 
B	2	M6 x 10mm Socket Screw 
C	1	Side Mount Adjustable Height Bracket 
D	1	M8 x 1.25 Knob Cap 

Mobile Workstation

OPTIONAL ACCESSORY 670067 Storage Pocket

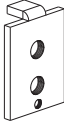

CONTENTS		
Ref.	Qty.	Description
1	1	Storage Pocket

HARDWARE CONTENTS		
Ref.	Qty.	Description
A	1	Front or Back Mount Adjustable Height Bracket 
B	2	M6 x 10mm Socket Screw 
C	1	Side Mount Adjustable Height Bracket 
D	1	5mm 

Assembly Instructions

Customer Service
US: 1-800-645-2986

Instrucciones de Ensamblaje

Servicio de atención al Cliente
México: 01.800.681.6940

Directives d'assemblage

Service à la clientèle
Canada: 888-645-2986

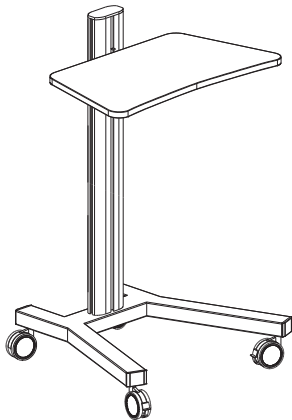

Estación de Trabajo Móvil

Modelos 670060 670061 670062 670063

CONTENIDO		
Ref.	Cant.	Descripción
1	1	Base móvil
2	2	Rueda/Freno
3	2	Rueda plana
4	1	Columna
5	1	Soporte de montaje
6	1	Superficie de trabajo
7	1	Tapa extremo
8	1	Guía de alambre

CONTENIDOS TORNILLERÍA		
Ref.	Cant.	Descripción
A	4	Tornillo Allen M8 x 65mm
	4	Arandela Plana
B	1	Soporte
	2	Tornillo Allen M6 x 10mm
C	1	6mm
		5mm
		4mm
		3mm
D	1	Llave de 17mm

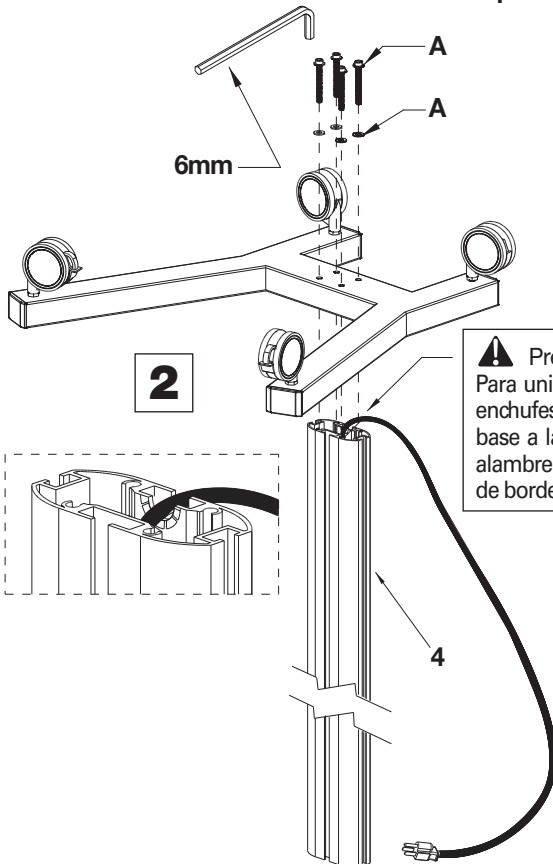
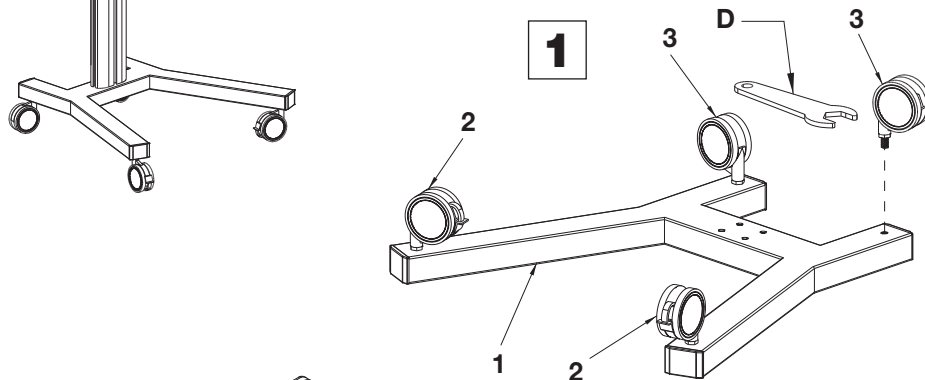

⚠ Precaución:
Para unidades equipadas con regleta de enchufes; al momento de ensamblar la base a la columna, asegúrese de que el alambre quede escondido dentro y lejos de bordes agudos.

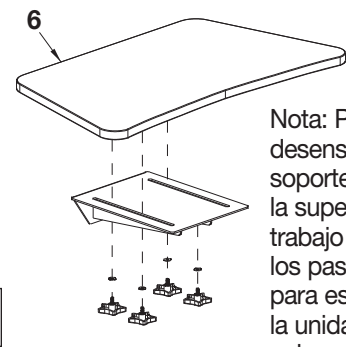

Nota: Primero desensamble el soporte desde la superficie de trabajo y siga los pasos 3 a 5 para ensamblar la unidad a la columna.

Nota: Conecte el soporte a una altura ajustable sin apretar para instalar el soporte.



4

Inserte el soporte de altura ajustable en la columna ponga el soporte de montaje a la altura deseada. Apriete los tornillos.

4A



8

Afirme la superficie de trabajo al soporte de montaje con la tornillería provista.

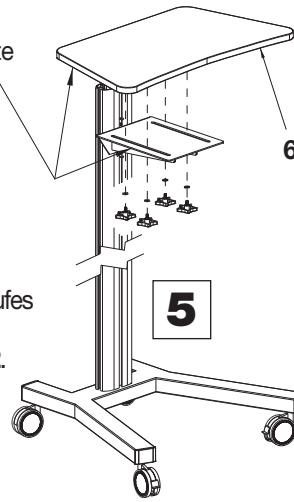

5

Se muestra con regleta de enchufes los modelos **670060, 670062.**

Enganche la guía de alambre en la columna y ponga a la altura deseada.

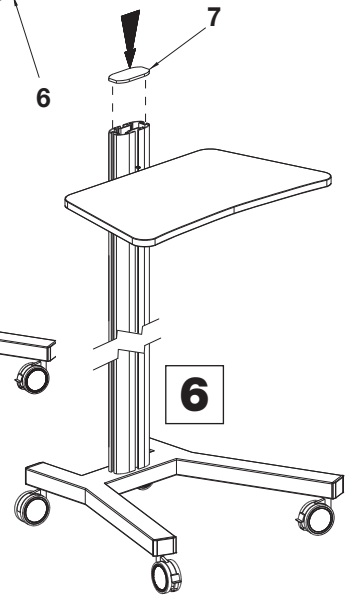

6

ACCESORIO OPCIONAL 670064 Montaje para monitor

CONTENIDO		
Ref.	Cant.	Descripción
1	1	Soporte de altura ajustable
2	1	Soporte de monitor
3	2	Tapa extremo

Nota: Consulte el manual del monitor para los tornillos del tamaño correcto para evitar daños.

CONTENIDOS TORNILLERÍA					
Ref.	Cant.	Descripción	Ref.	Cant.	Descripción
					Usar para conectar el monitor al soporte de monitor.
	1	Soporte de montaje frontal o posterior		4	Tornillo Allen M4 x 15mm
A	2	Arandela plana de 8mm		4	Tornillo Allen M5 x 15mm
	2	Perilla M8 x 1,25	B	4	Tornillo Allen M6 x 15mm
	1	6mm		4	Arandela plana de 4mm
C	1	5mm		4	Arandela plana de 5mm
	1	3mm		4	Arandela plana de 6mm

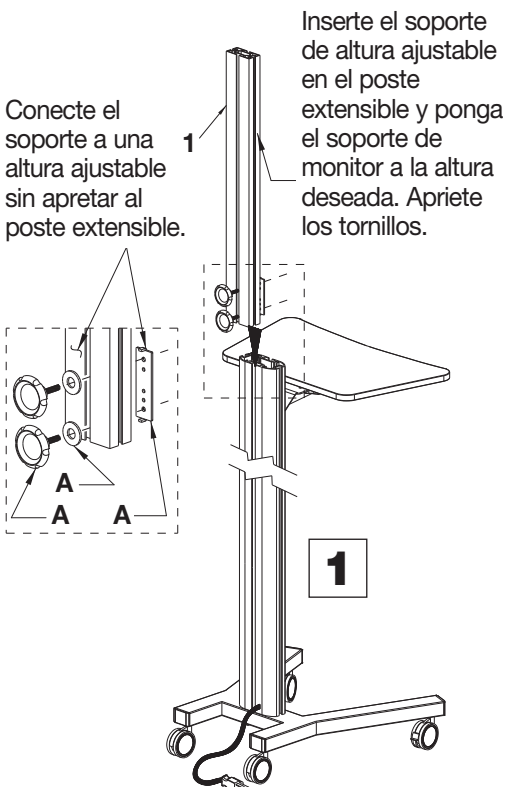

Inserte el soporte de altura ajustable en el poste extensible y ponga el soporte de monitor a la altura deseada. Apriete los tornillos.

Conecte el soporte a una altura ajustable sin apretar al poste extensible.

1

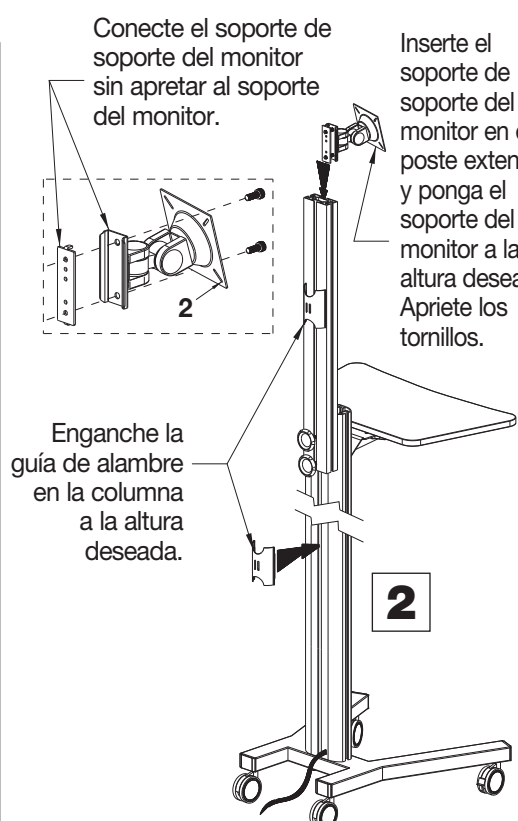

Conecte el soporte de soporte del monitor sin apretar al soporte del monitor.

Inserte el soporte de soporte del monitor en el poste extensible y ponga el soporte del monitor a la altura deseada. Apriete los tornillos.

Enganche la guía de alambre en la columna a la altura deseada.

2

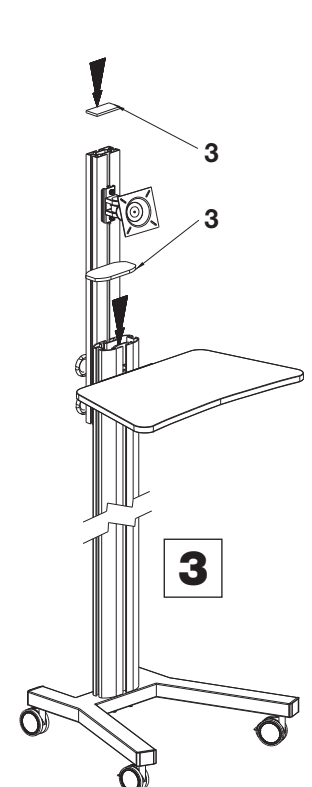

3

Estación de Trabajo Móvil

ACCESORIO OPCIONAL 670066 Bandeja de impresora

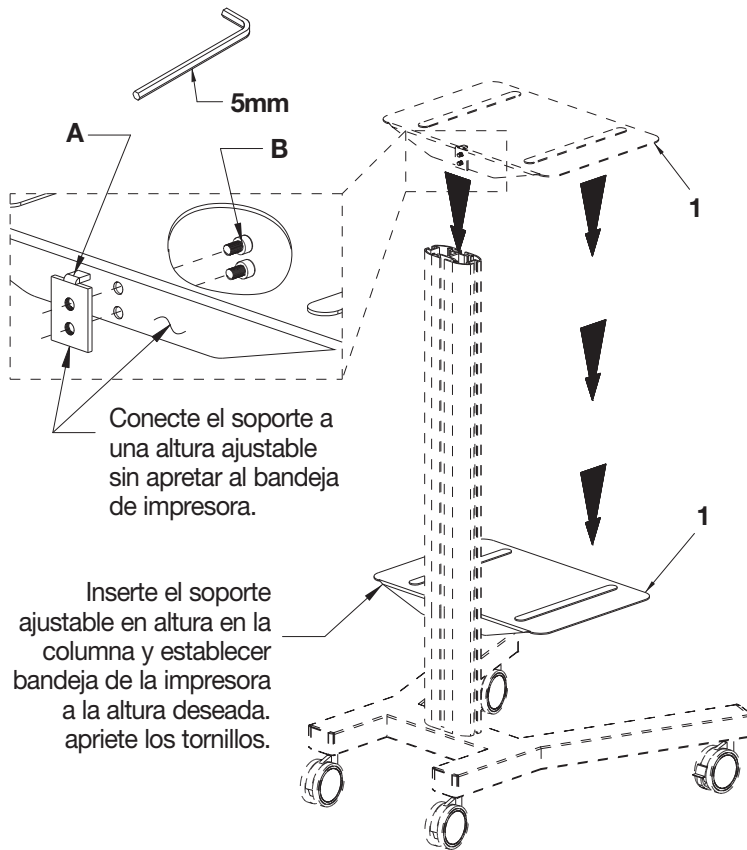

CONTENIDO		
Ref.	Cant.	Descripción
1	1	Bandeja de impresora

CONTENIDOS TORNILLERÍA		
Ref.	Cant.	Descripción
A	1	Soporte de altura ajustable para montaje frontal o posterior
B	2	Tornillo Allen M6 x 10mm
C	1	Soporte de altura ajustable para montaje lateral

ACCESORIO OPCIONAL Contenedor de CPU

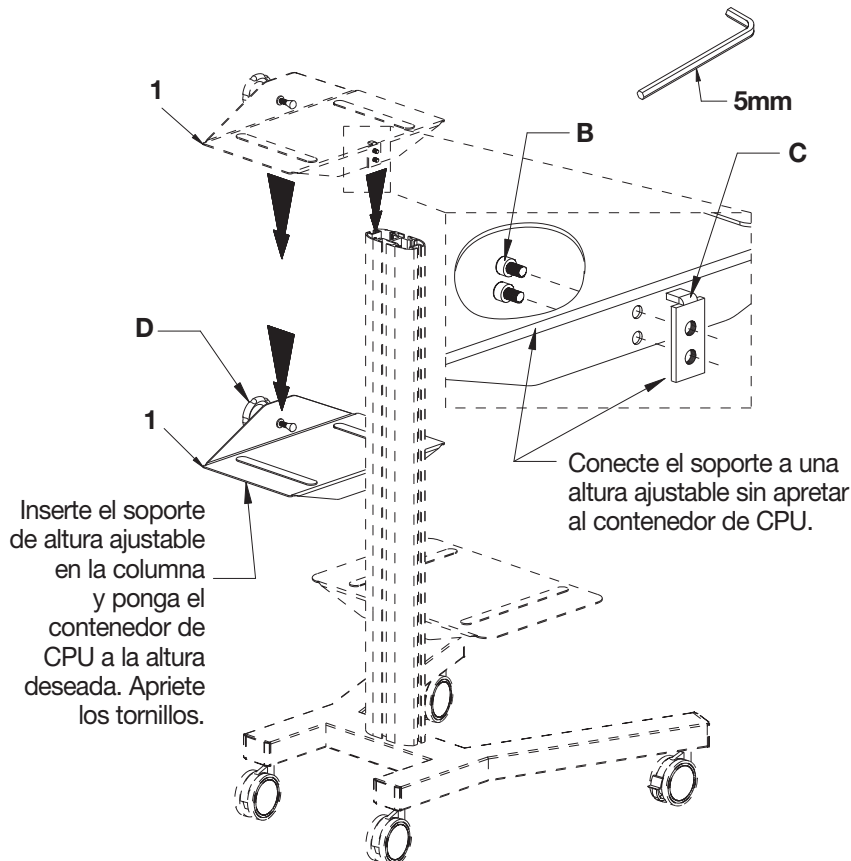

CONTENIDO		
Ref.	Qty.	Description
1	1	Contenedor de CPU

CONTENIDOS TORNILLERÍA		
Ref.	Qty.	Description
A	1	Soporte de altura ajustable para montaje frontal o posterior
B	2	Tornillo Allen M6 x 10mmw
C	1	Soporte de altura ajustable para montaje lateral
D	1	Perilla M8 x 1,25 Tapa

Estación de Trabajo Móvil

ACCESORIO OPCIONAL 670067 Bolsillo para almacenaje

Inserte el soporte de altura ajustable en la columna y ponga el bolsillo para almacenaje a la altura deseada. Apriete los tornillos.

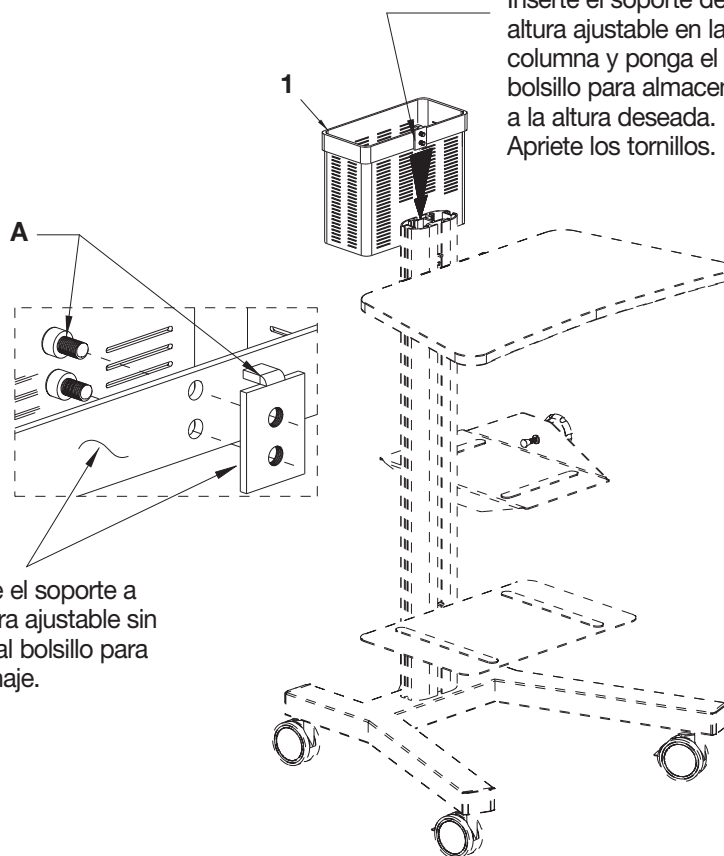





Conecte el soporte a una altura ajustable sin apretar al bolsillo para almacenaje.

CONTENIDO

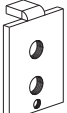
Ref.	Cant.	Descripción
1	1	Bolsillo para almacenaje

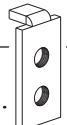
CONTENIDOS TORNILLERÍA

Ref.	Cant.	Descripción
A	1	Soporte de altura ajustable para montaje frontal o posterior 
B	2	Tornillo Allen M6 x 10mm 
C	1	Soporte de altura ajustable para montaje lateral 
D	1	5mm 

Assembly Instructions

Customer Service
US: 1-800-645-2986

Instrucciones de Ensamblaje

Servicio de atención al Cliente
México: 01.800.681.6940

Directives d'assemblage

Service à la clientèle
Canada: 888-645-2986

Station De Travail Mobile

Modèles 670060 670061 670062 670063

CONTENU		
Réf.	Qté.	Description
1	1	Base mobile
2	2	Roulette/Frein
3	2	Roulette plate
4	1	Colonne
5	1	Fixation de soutien
6	1	Surface de travail
7	1	Embout
8	1	Fil-guide

CONTENU DU MATERIEL		
Réf.	Qté.	Description
A	4	Vis à tête creuse de M8 x 65mm
	4	Rondelle plate.....
B	1	Fixation
	2	Vis à tête creuse de M6 x 10mm
C	1	6mm
		5mm
		4mm
		3mm
D	1	Clé de 17mm

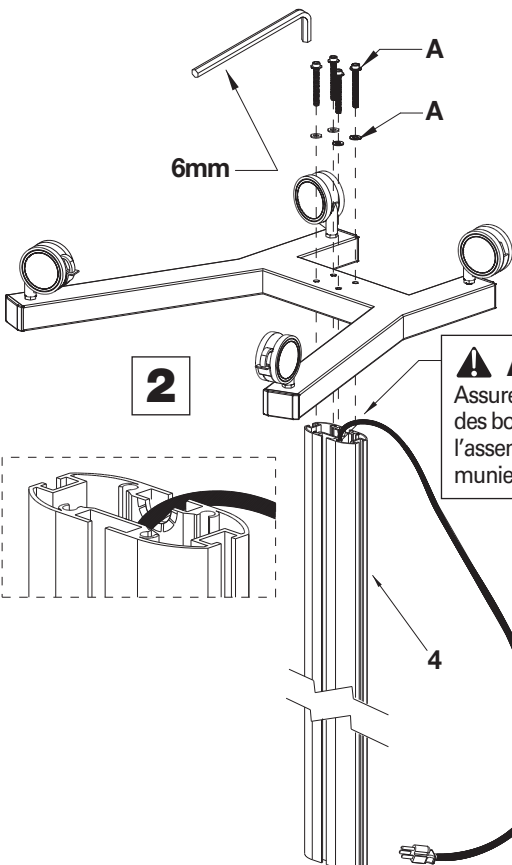
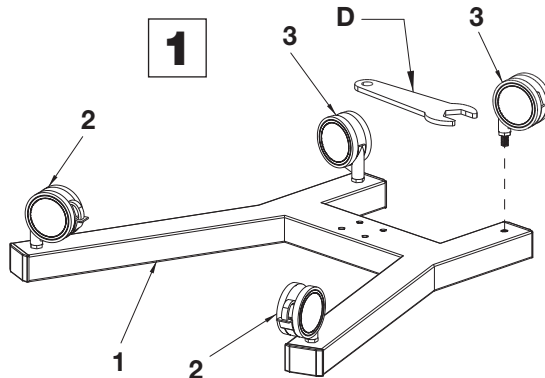
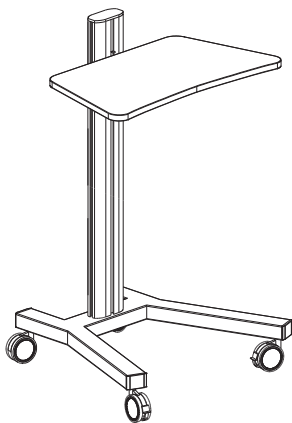

⚠ AVERTISSEMENT:
Assurez-vous que le fil est sécurisé et à l'écart des bords abruptes lorsque vous procédez à l'assemblage de la colonne pour les unités munies d'une bande de puissance.

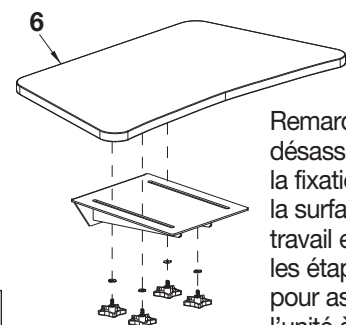

Remarque : désassembler la fixation de la surface de travail et suivez les étapes 3 à 5 pour assembler l'unité à la colonne.

Remarque : Joindre la fixation ajustable lâchement à la fixation de montage.

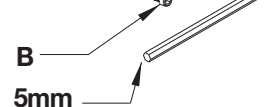

Station de Travail Mobile

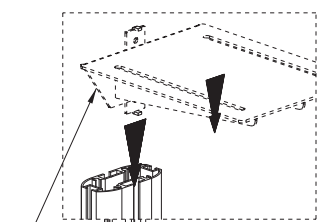

4

Insérez la fixation ajustable dans la colonne et réglez la hauteur de la fixation à la hauteur désirée. Serrer les vis.

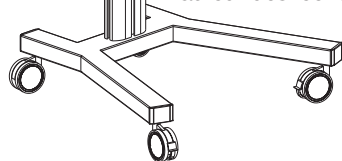

Sécuriser la surface de travail à la fixation de montage avec le matériel fourni.

4A

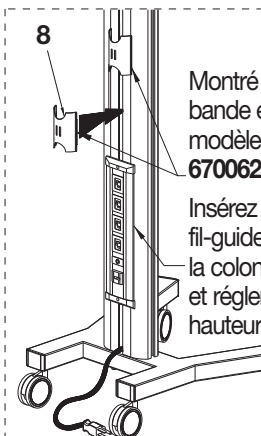

8

Montré avec la bande électrique modèle 670060, 670062.

Insérez le fil-guide dans la colonne et réglez à la hauteur désirée.

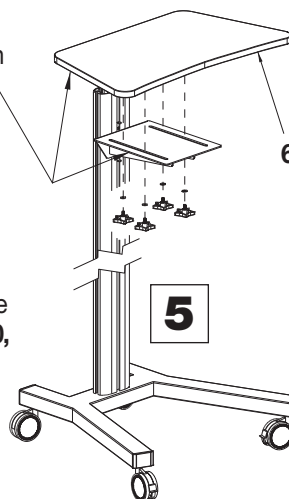

5

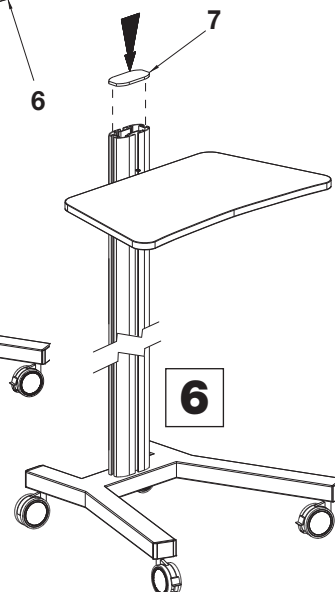

6

ACCESSOIRE OPTIONNEL Monture De L'écran 670064

CONTENU		
Réf.	Qté.	Description
1	1	Fixation à hauteur ajustable
2	1	Monture de l'écran
3	2	Embout

Remarque: Consultez le manuel du moniteur pour les vis de taille correcte pour éviter tout dommage.

CONTENU DU MATERIEL						
Réf.	Qté.	Description	Réf.	Qté.	Description	
	1	Fixation de montage avant ou arrière			Utilise pour fixer l'écran sur le soutien de l'écran	
A	2	Rondelle plate de 8mm		4		
	2	Bouton M8 x 1.25		4	Vis creuse M5 x 15mm	
	1	6mm	B	4	Vis creuse M6 x 15mm	
	1	5mm		4	Rondelle plate de 4mm	
C	1	3mm		4	Rondelle plate de 5mm	
	1			4	Rondelle plate de 6mm	

Fixer lâchement la fixation de soutien ajustable au poteau extensible.

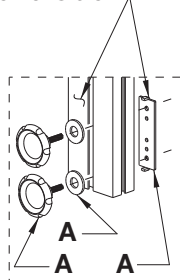

Insérer la fixation à hauteur ajustable dans le poteau extensible et placer la monture de l'écran à la hauteur désirée. Serrer les vis.

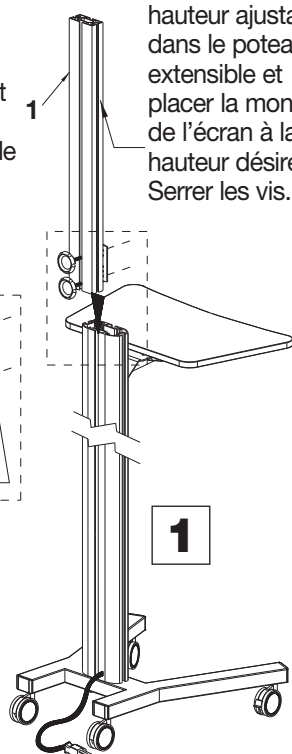

1

Fixer lâchement la fixation de soutien de l'écran à la monture de l'écran.

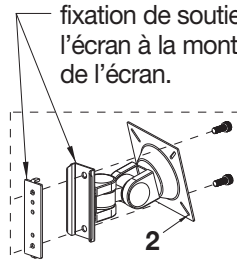

Insérer le fil-guide dans la colonne à la hauteur désirée

Insérer la fixation de montage de l'écran dans le poteau extensible et régler la monture de l'écran à la hauteur désirée. Serrer les vis.

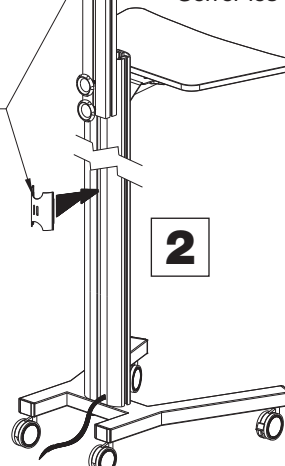

2

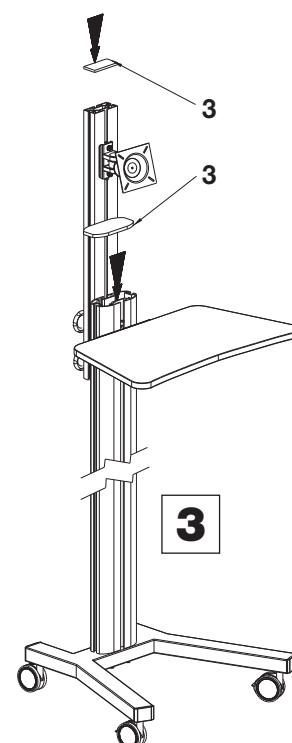



3

Station de Travail Mobile

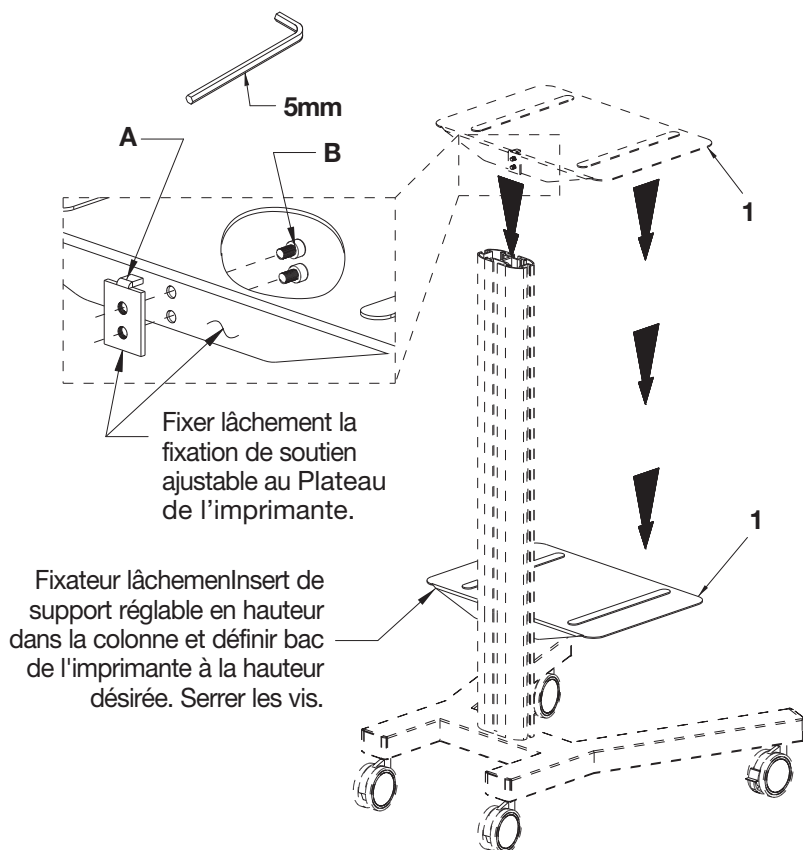
ACCESSOIRE OPTIONNEL Plateau de l'imprimante 670066



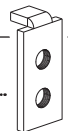

CONTENU		
Réf.	Qté.	Description
1	1	Plateau de l'imprimante

CONTENU DU MATERIEL		
Réf.	Qté.	Description
A	1	Avant ou arrière de la fixation ajustable de la monture arrière 
B	2	Vis creuse M6 x 10mm 
C	1	Fixation à hauteur ajustable de la monture latérale 

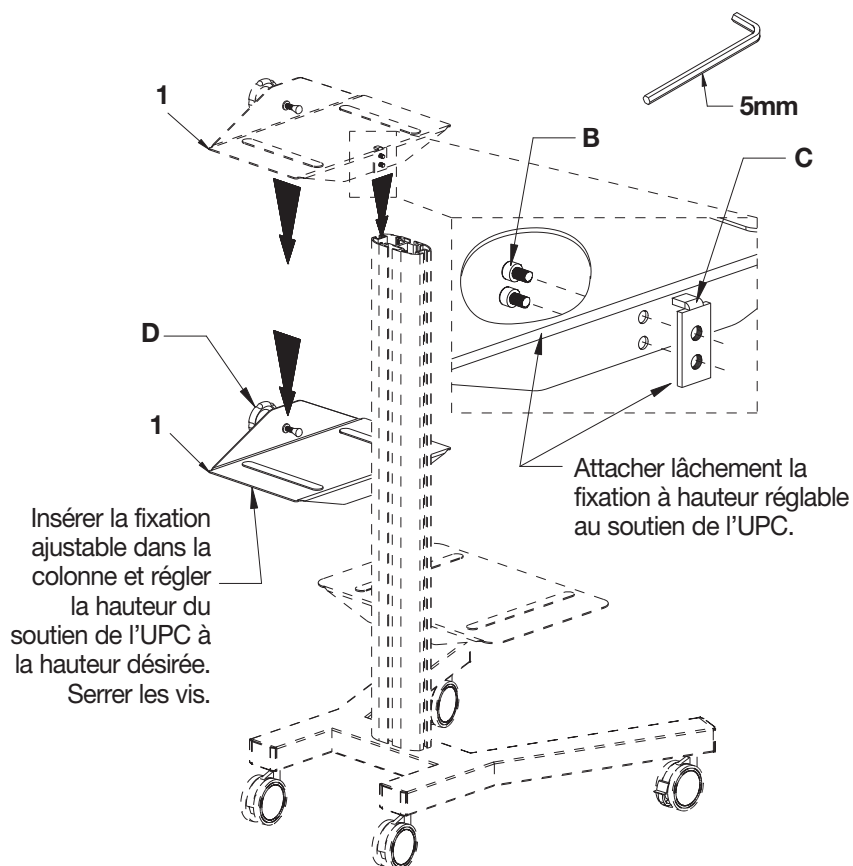
ACCESSOIRE OPTIONNEL Soutien UPC 670065

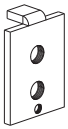

CONTENU		
Réf.	Qté.	Description
1	1	Soutien UPC

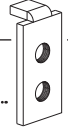
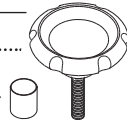
CONTENU DU MATERIEL		
Réf.	Qté.	Description
A	1	Avant ou arrière de la fixation ajustable de la monture arrière 
B	2	Vis creuse M6 x 10mm 
C	1	Fixation à hauteur ajustable de la monture latérale 
D	1	Bouton M8 x 1.25 D'embout 

Station de Travail Mobile

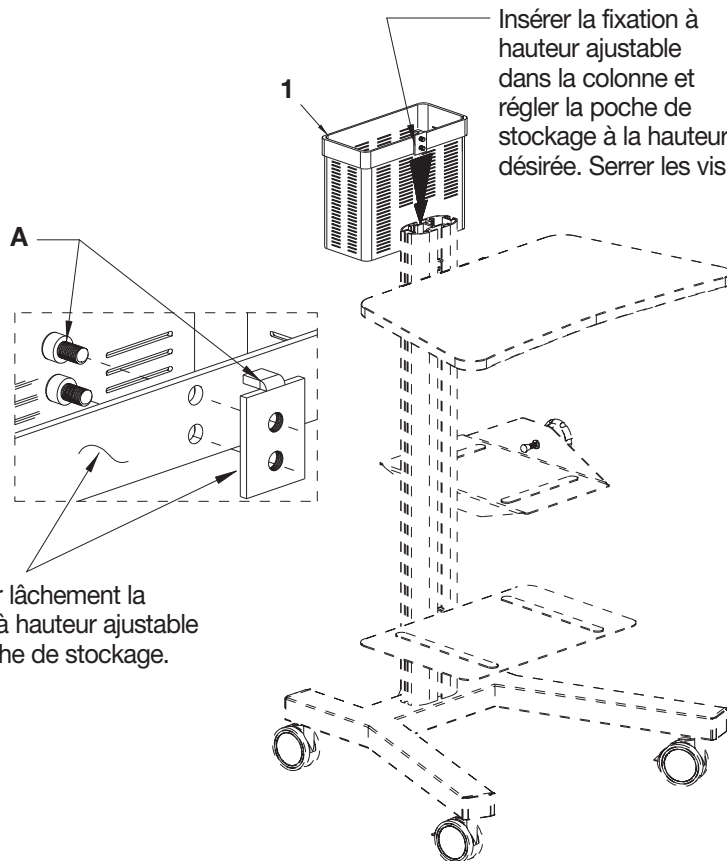

ACCESSOIRE OPTIONNEL Poche de stockage 670067



CONTENU

Ref.	Qty.	Description
1	1	Poche de stockage

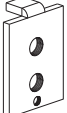
CONTENU DU MATERIEL

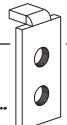
Ref.	Qty.	Description
A	1	Avant ou arrière de la fixation ajustable de la monture arrière 
B	2	Vis creuse M6 x 10mm 
C	1	Fixation à hauteur ajustable de la monture latérale 
D	1	5mm 