

Assembly Instructions	Instrucciones de Ensamblaje	Directives d'assemblage
Customer Service US: 1-800-645-2986	Servicio de atención al Cliente México: 01.800.681.6940	Service à la clientèle Canada: 888-645-2986

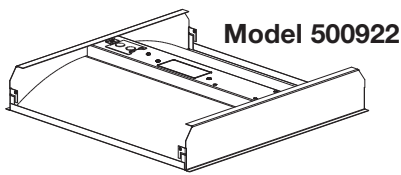

LED Recessed Troffers

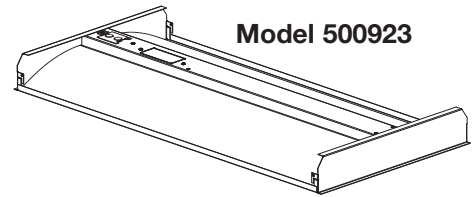

Remove screw holding access cover plate and remove the necessary knockout.

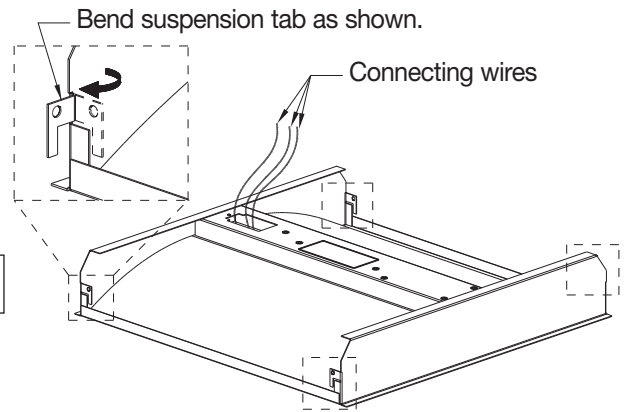
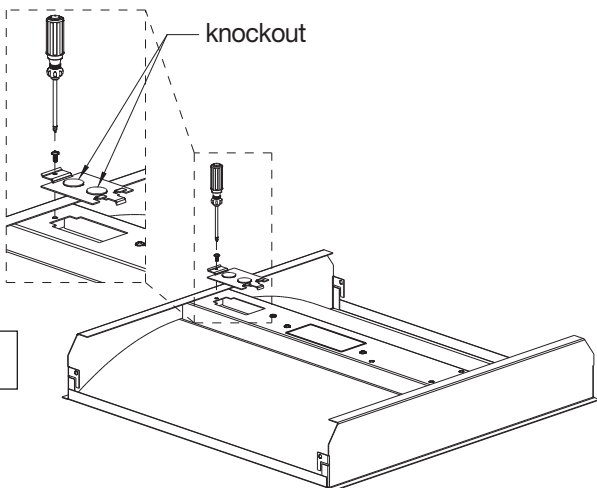

GENERAL SAFETY INFORMATION

- To reduce the risk of property damage, personal injury, and/or death from fire, electric shock, falling equipment, and other hazards please read all instructions and warnings.
- Installation, service, and maintenance should be performed by a qualified licensed electrician.
- Do not install this product on damp, moist, or newly plastered surfaces.
- Fixture LEDs are not replaceable.
- **DO NOT INSTALL DAMAGED PRODUCTS!**

⚠ WARNING

RISK OF ELECTRICAL SHOCK

- Turn off electrical power at fuse or circuit breaker box prior to power supply installation.
- Turn off power prior to performing any maintenance.
- Verify supply voltage accuracy.
- Ensure all electrical and grounded connections are in accordance with the National Electrical Code and any other applicable local code requirements.
- All wiring connections should be capped with approved wire connectors.

SPECIFICATIONS

Input: AC 100-277V 50/60HZ

Model 500922: 2 x 2 Recessed Troffer
36 Watts, 3960 Lumens, Color Temperature 4000K

Model 500923: 2 x 4 Recessed Troffer
50 Watts, 5500 Lumens, Color Temperature 4000K

⚠ CAUTION

RISK OF INJURY

- Wear gloves and safety glasses at all times during unit installation or maintenance.
- Avoid direct eye exposure to light source.
- Ensure fixtures are properly secured to T-bar grid and ceiling, using wire or aircraft cable capable of supporting a minimum of 100 lbs.

RISK OF FIRE

- Keep combustible and other materials away from luminaires and lamp/lens.
- Do not install insulation within 2 inches of light fixture.

LED Recessed Troffers

3

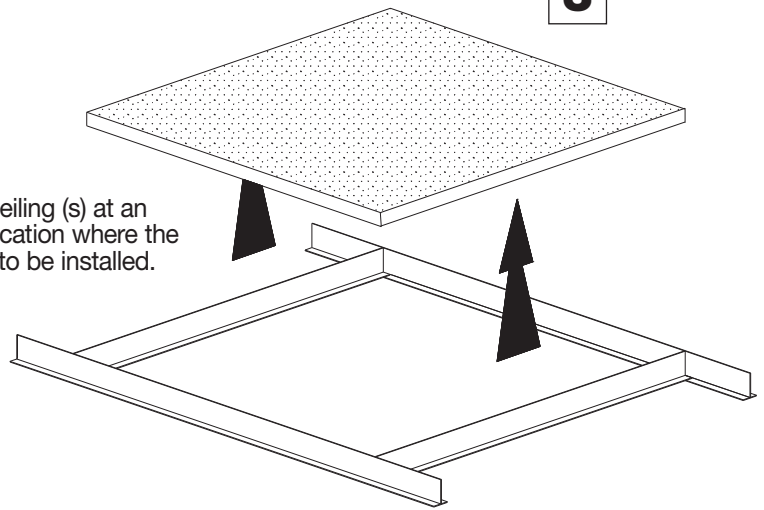

Remove the ceiling (s) at an appropriate location where the light fixture is to be installed.

Set light fixture into the suspension with tabs. Hang over the T-Bar as shown.

4

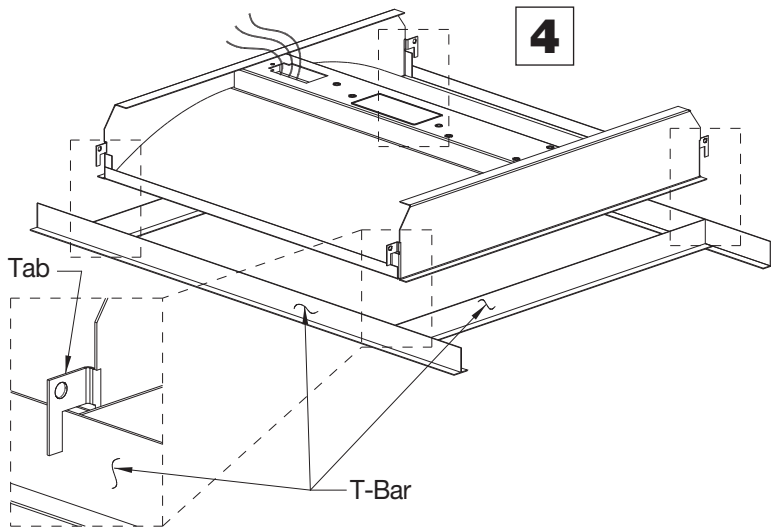

After securing the light fixture to the T-Bar, secure the light fixture to the ceiling with aircraft cable or wires capable of supporting 100 lbs. minimum.

5

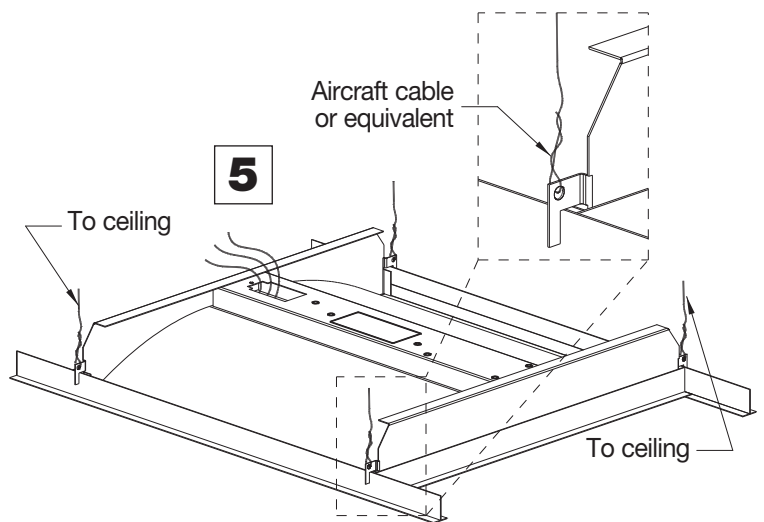

Connect cable wires with appropriate relief strain and wire connectors (not provided). Make sure ALL wires are tucked in before reinstalling the cover plate.

6

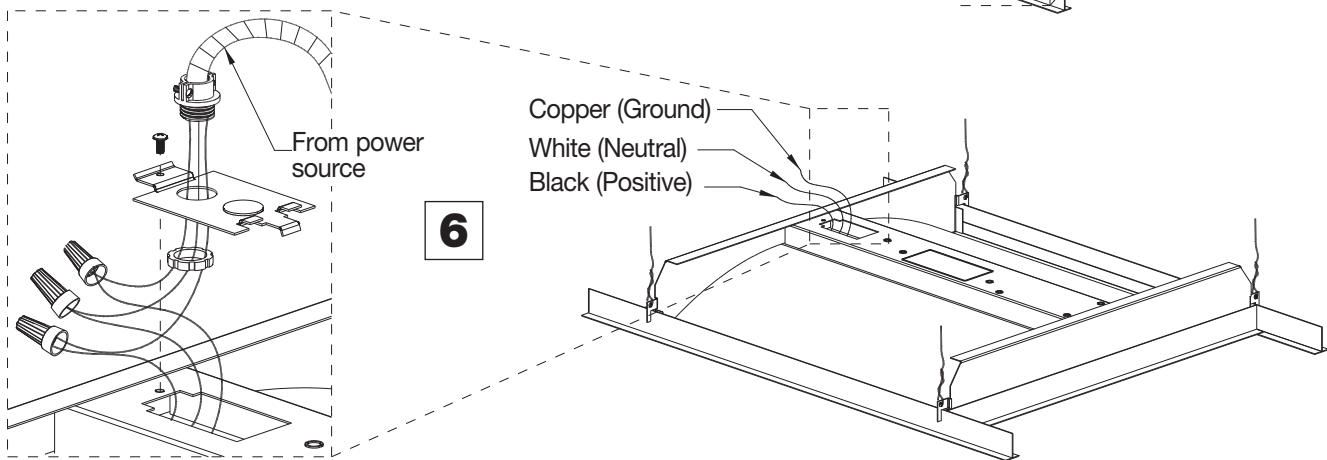

This device complies with part 15 of the FCC Rules. Operation is subject to the following two conditions: (1) This device may not cause harmful interference, and (2) this device must accept any interference received, including interference that may cause undesired operation.

NOTE: This equipment has been tested and found to comply with the limits for a Class B digital device, pursuant to part 15 of the FCC Rules. These limits are designed to provide reasonable protection against harmful interference in a residential installation. This equipment generates, uses and can radiate radio frequency energy and, if not installed and used in accordance with the instructions, may cause harmful interference to radio communications. However, there is no guarantee that interference will not occur in a particular installation. If this equipment does cause harmful interference to radio or television reception, which can be determined by turning the equipment off and on, the user is encouraged to try to correct the interference by one or more of the following measures:

- Reorient or relocate the receiving antenna.
- Increase the separation between the equipment and receiver.
- Connect the equipment into an outlet on a circuit different from that to which the receiver is connected.
- Consult the dealer or an experienced radio/TV technician for help.