

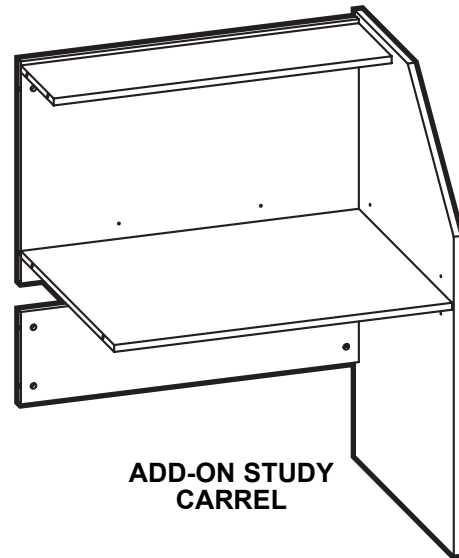

BSC/ASC

BASE STUDY CARREL ADD-ON STUDY CARREL

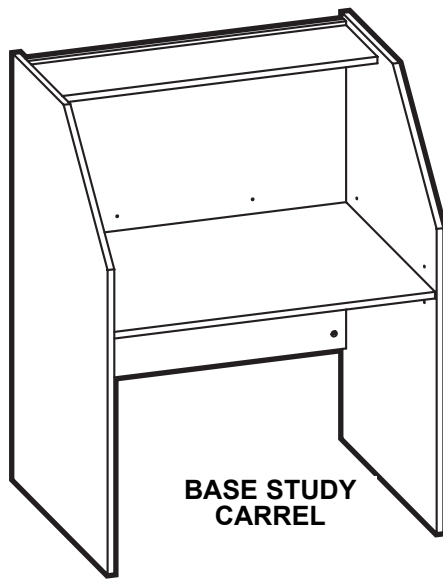

IMPORTANT!

Assembly may require the assistance of another person.

Before you begin assembly:

READ THE DIRECTIONS all the way through one time. This will speed up the process and help you understand the sequence of steps.

COUNT THE PARTS AND HARDWARE before assembly. This ensures you have received all necessary parts before you begin.

TOOLS: You may need a Phillips head screwdriver, a medium slotted screwdriver or a plastic mallet. To protect your new furniture from damage during assembly, it is recommended to work on a carpeted surface.

In the event any parts are missing from this package, send your name, address, telephone number, and a description of the missing part(s) to: PARTS, Box 1420, Missoula, MT 59806 or call: 1-800-769-5693 or FAX 1-800-445-5281.

CAUTION: On assemblies requiring glue, make sure the unit is assembled correctly before gluing. Once this unit is assembled with glue, the manufacturer will not be responsible for damaged parts. Keep a damp cloth or sponge handy to wipe off excess glue.

To care for this furniture, simply wipe with a cloth dampened with glass cleaner containing ammonia-D.

PARTS DIAGRAM

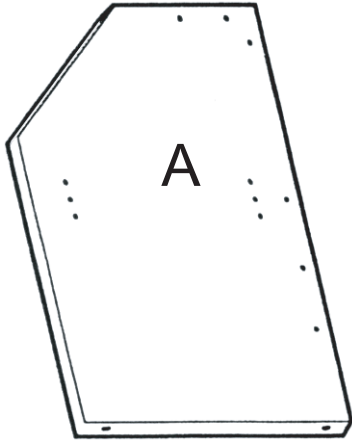

Left Side —BSC	06000541	1 ea.
----------------	----------	-------

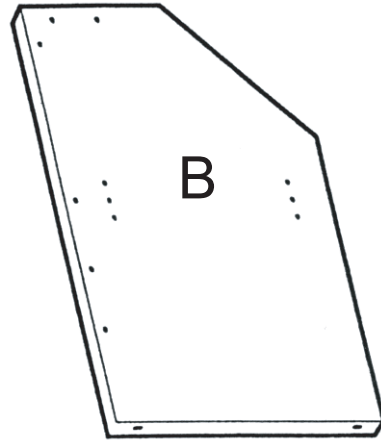

Right Side —BSC	06000541	1 ea.
-----------------	----------	-------

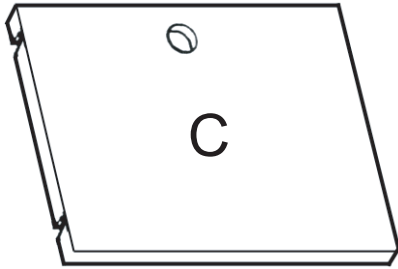

Top—BSC	06000501	1 ea.
---------	----------	-------

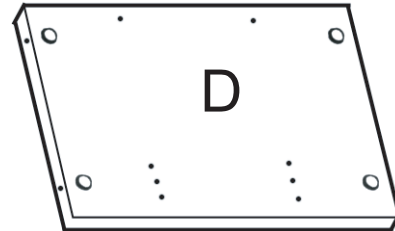

Upper Back—BSC	06000557	1 ea.
----------------	----------	-------

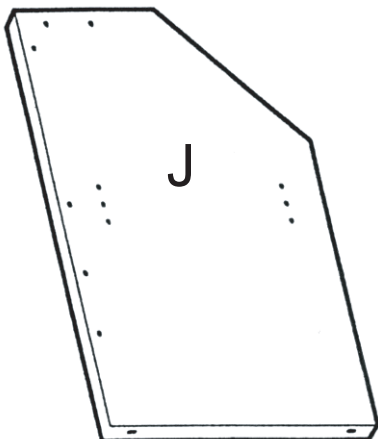

Divider—ASC	06000544	1 ea.
-------------	----------	-------



Lower Back—BSC Loser Back—ASC	06000560	1 ea.
----------------------------------	----------	-------



Shelf—BSC Shelf—ASC	06000527	1 ea.
------------------------	----------	-------

HARDWARE



H1	Minifix Cam	909810	BSC - 14 ea. ASC - 14 ea.
----	-------------	--------	------------------------------



H2	Insert	274650	BSC - 4 ea. ASC - 2 ea.
----	--------	--------	----------------------------

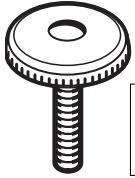

H3	Leveler	300870	BSC - 4 ea. ASC - 2 ea.
----	---------	--------	----------------------------



H4	Minifix Bolt	909834	BSC - 14 ea. ASC - 02 ea.
----	--------------	--------	------------------------------



H5	Short Rafix Bolt	909923	BSC - 6 ea. ASC - 6 ea.
----	------------------	--------	----------------------------



H6	Rafix Cam	909910	BSC - 6 ea. ASC - 6 ea.
----	-----------	--------	----------------------------



H7	Round Grommet	H1480	BSC - 1 ea. ASC - 1 ea.
----	---------------	-------	----------------------------



H8	Through Bolt	909852	BSC - 0 ea. ASC - 6 ea.
----	--------------	--------	----------------------------

Using the Minifix System:

Insert the Minifix Cams into the appropriate holes with the arrow facing outwards as shown.

When screwing post into hole, **Do Not** over tighten. Screw post down until bottom face of post flange just touches board surface.

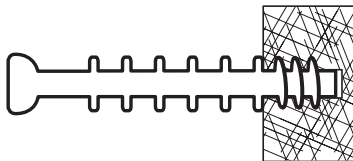

Using the #2 Phillips screwdriver, rotate the Cam Devices a half turn clockwise until snug.

To disassemble, turn the Cam Devices counter-clockwise and remove panels.

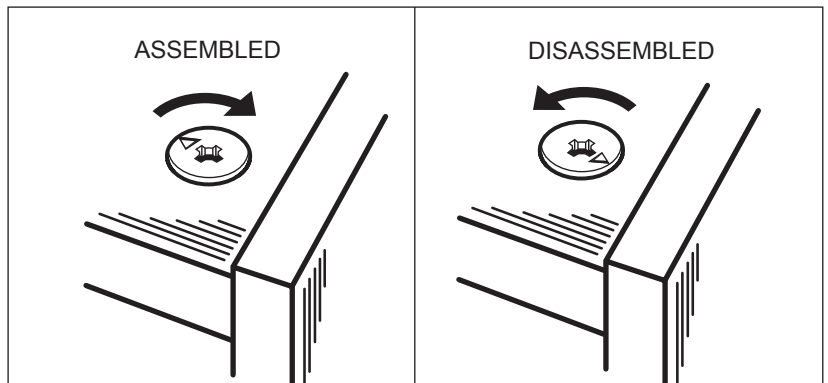
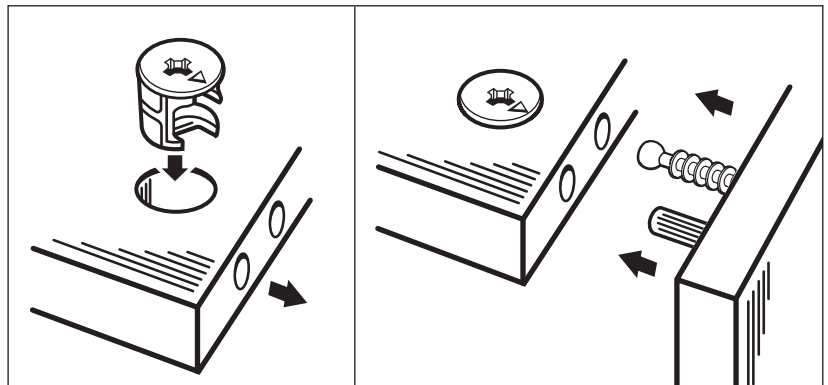

Using the Rafix System:

Insert the Rafix Cams into the appropriate holes. The flat edge of the cam should be facing the edge of the panel.

Slide Rafix Cams of the panel to be attached onto the corresponding posts.

When screwing post into hole, **Do Not** over tighten. Screw post down until bottom face of post flange just touches board surface.

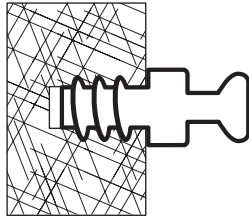

Using a #3 Phillips screwdriver, turn the rotating portion of the Rafix Cam a 1/2 turn clockwise to secure. **IMPORTANT!** Do not exceed 1/2 turn when tightening cams. Turn 1/2 turn counterclockwise to disassemble and remove panel.

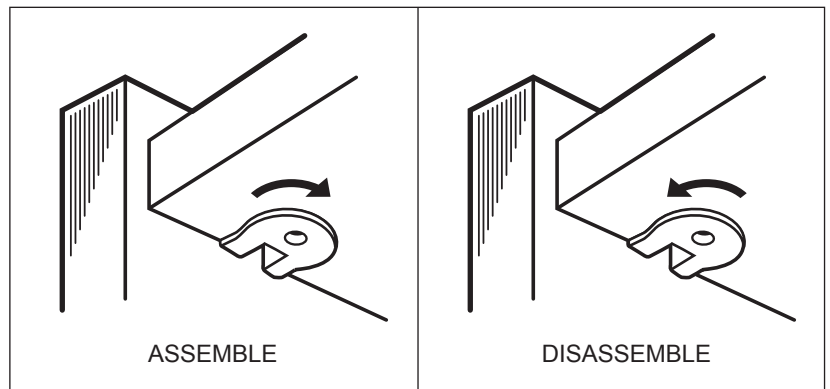
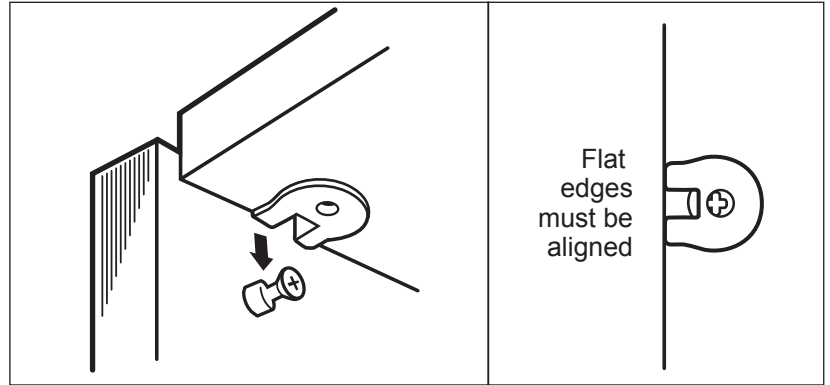

#1

Place the Upper Back (D), Lower Back (E) and the Shelf (G) onto a clean, carpeted surface with the pre-drilled holes facing up.

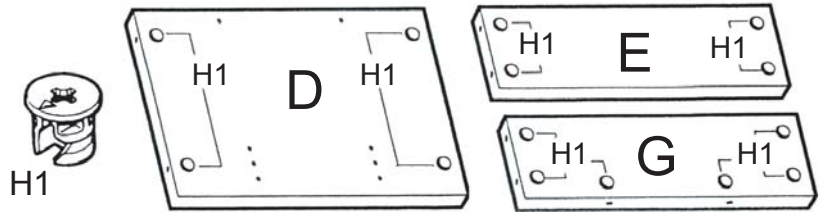

Insert four Minifix Cams (H1) into each back and six Cams into the Shelf with the arrows of the cams facing out.

#2

Using a plastic mallet, tap Inserts (H2) until flush with the surface in the bottom edges of the Left Side (A) and Right Side (B) as shown. Screw the Levelers (H3) into the Inserts.

Note: Adjust the Levelers after assembly is complete and the unit is in place.

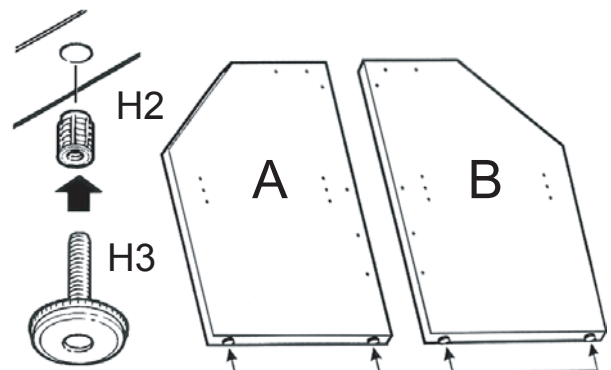

#3

Place the Left Side (A) and Right Side (B) with the pre-drilled holes facing up.

Screw six Minifix bolts (H4) into the Left Side (A) and Right Side (B) where indicated.

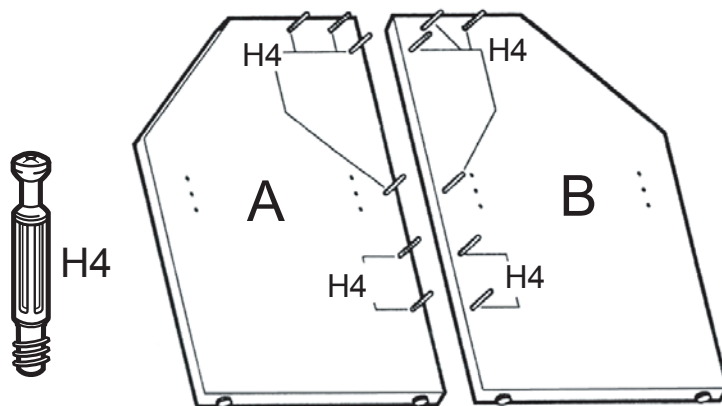

#4

Elevate the Upper Back (D) slightly with some cardboard packing material as shown. Position the cams of the Shelf (G) onto the bolts of the Upper Back as shown. Turn the arrows of the cams (H1) of the Shelf clockwise to secure.

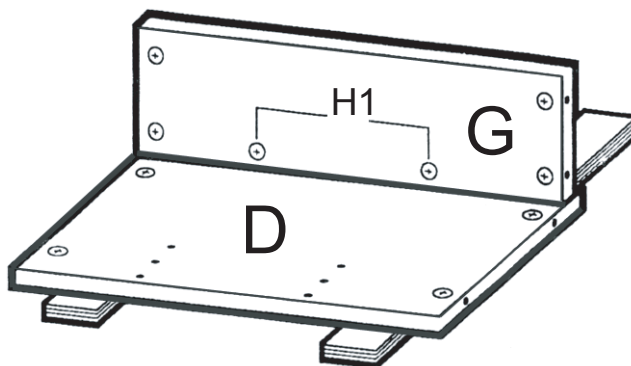

#5

Position the Left Side (A) with the front edge as shown onto the Upper Back (D) and Shelf (G) assembly. Turn the arrows of the cams (H1) clockwise to secure in place.

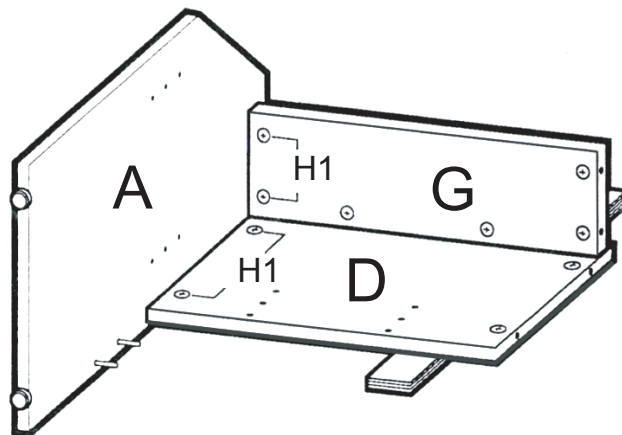

#6

Position the Lower Back (E) onto the Left Side (A) as shown. Turn the arrows of the cams (H1) clockwise to secure.

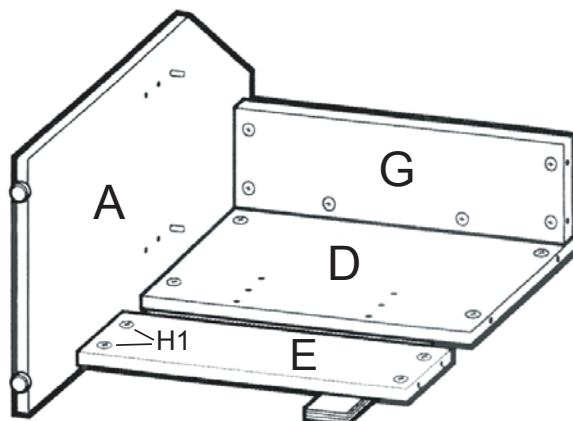

IMPORTANT! If you are assembling this unit in conjunction with an ASC Add-On Study Carrel, skip ahead to Step #12 to continue the assembly procedure!

#7

With the assistance of another person, position the Right Side (B) with the front edge as shown onto the assembly. Turn the arrows of the cams (H1) clockwise to secure.

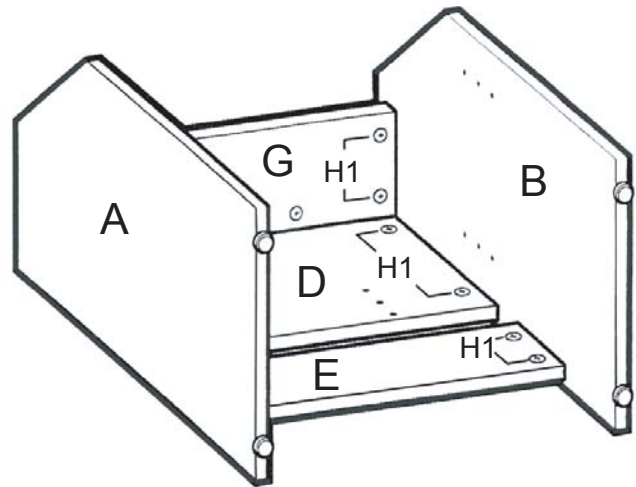

#8

With the assistance of another person, turn the unit upright. Select a preferred height of the Top (C) at this time. Screw two Short Rafx Bolts (H5) into the appropriate set of pre-drilled holes in the Left Side (A), Upper Back (D) and Right Side (B) as shown.

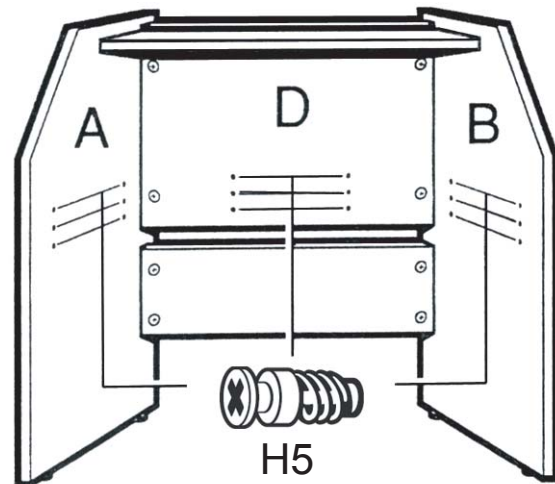

#9

Insert six Rafx Cams (H6) into the underside of the Top (C) with the flat edge facing out. Tap until cams are fully seated in place as shown.

NOTE: The edge of the Rafx Cam must be aligned with the shelf edge. **Rafx Cams cannot be repositioned if installed incorrectly.**

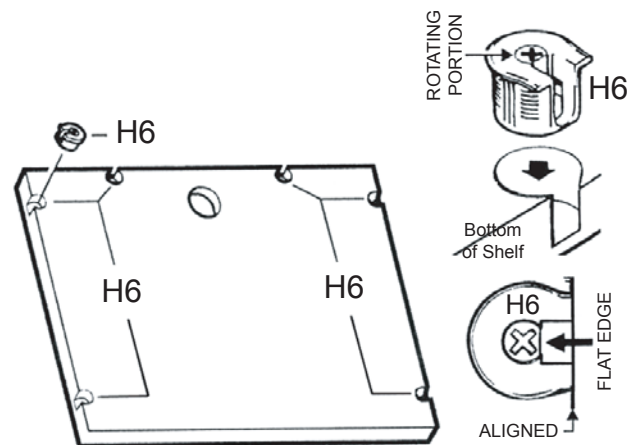

#10

Position the Top (C) onto the Rafix Bolts (H5) of the Left Side (A), Upper Back (D) and Right Side (B) as shown. Using a #3 Phillips screwdriver, turn the rotating portions of the Rafix Cams (H6) 1/4-turn clockwise to secure.

NOTE: Do not exceed 1/4-turn when tightening!

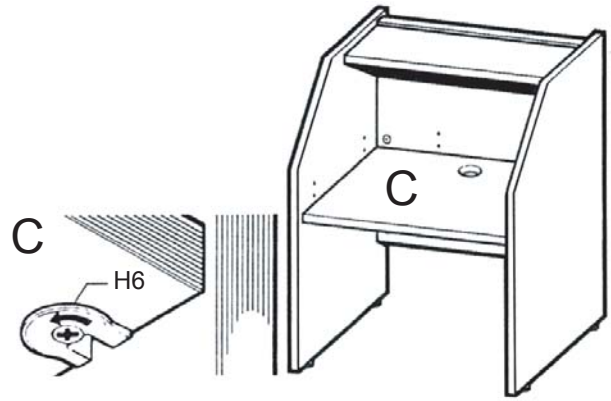

#11

Press a Round Grommet (H7) into the holes in the Top (C) as shown.

Assembly of the Study Carrel is now complete.

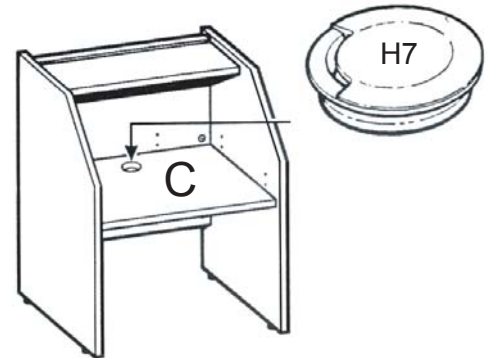

IMPORTANT! Continue following these instructions to assemble a BSC Base Study Carrel in conjunction with an ASC Add-On Study Carrel.

NOTE: If you are attaching an ASC Add-On Study Carrel to a previously assembled BSC Base Study Carrel, it will be necessary to partially disassemble the existing base unit.

With the assistance of another person, lower the base unit onto its back. Turn the rotating portions of the six Rafix Cams (H6) of the Top (C) counterclockwise. Remove the Top (C).

Rotate the arrows of the indicated Minifix Cams (H1) of the Upper Back (D), Lower Back (E) and Shelf (G) counterclockwise.

With assistance, remove the Right Side (B) and set aside.

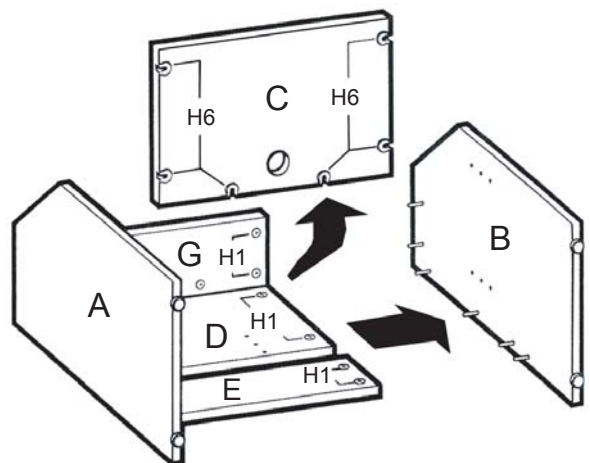

#12

Insert four Minifix Cams (H1) into each back (D & E) and six cams (H1) into a Shelf (G) with the arrows of the cams facing out.

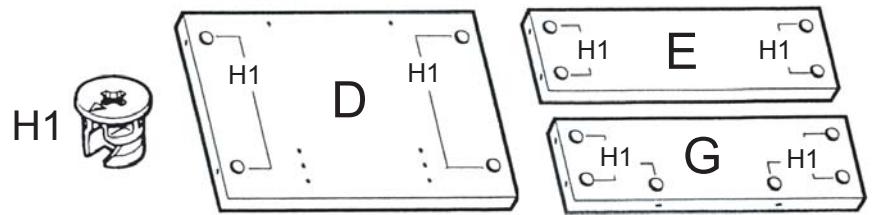

#13

Using a plastic mallet, tap Inserts (H2) until flush with the surface in the bottom edges of the Divider (J) as shown. Screw the Levelers (H3) into the Inserts. Adjust the Levelers after assembly is complete and the unit is in place.

Insert six Through Bolts (H8) into the right side of the Divider where indicated.

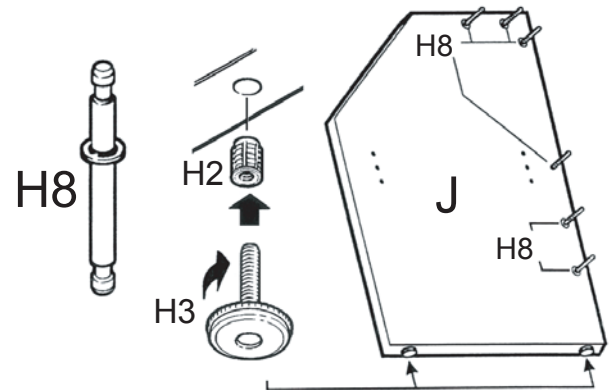

#14

With the assistance of another person, position the Divider (J) with the front edge as shown onto the Upper Back (D), Lower Back (E) and Shelf (G). Turn the arrows of the cams (H1) clockwise to secure.

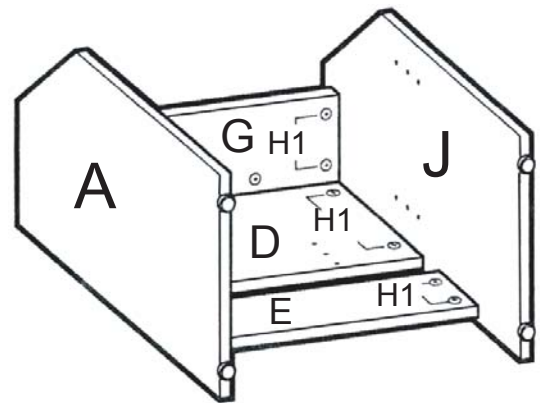

#15

Elevate an Upper Back (D) slightly with some cardboard packing material as shown. Position the cams of a Shelf (G) onto the bolts of the Upper Back as shown. Turn the arrows of the cams (H1) of the Shelf clockwise to secure.

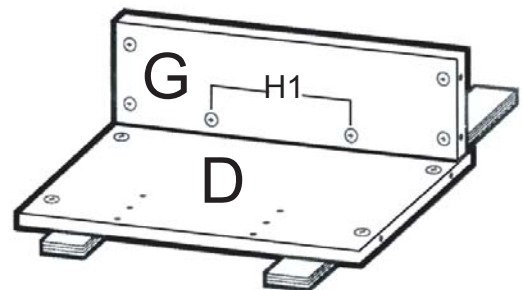

#16

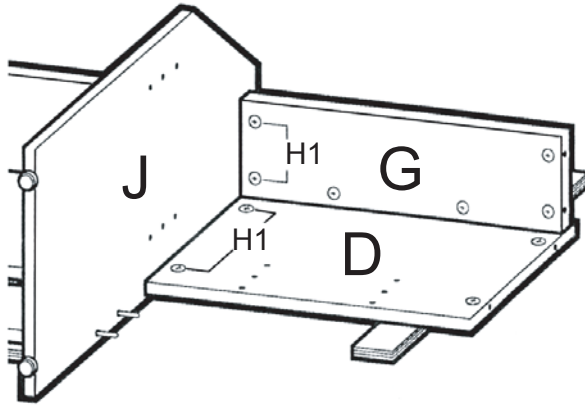

Position the Upper Back (D) and Shelf (G) assembly onto the Divider (J). Turn the arrows of the cams (H1) clockwise to secure in place.

#17

Position the Lower Back (E) onto the Divider (J) as shown and turn the arrows of the cams (H1) clockwise to secure.

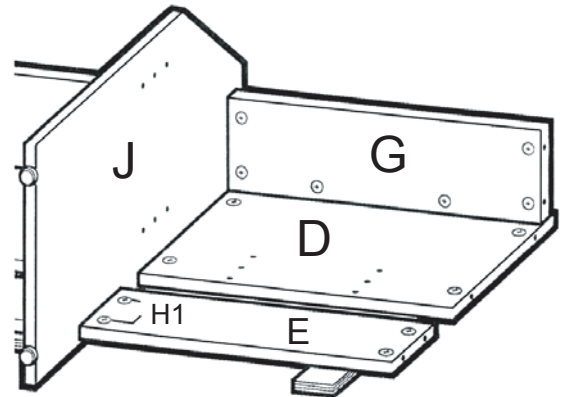

#18

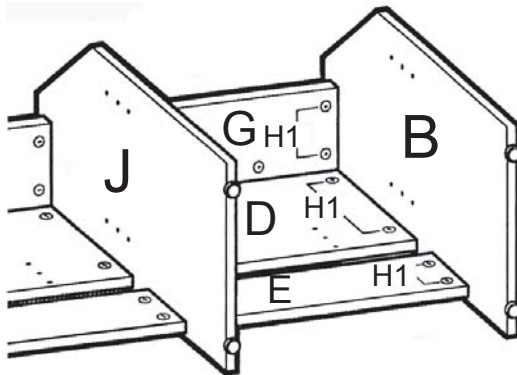

With the assistance of another person, position the Right Side (B) onto the unit and turn the arrows of the cams (H1) clockwise to secure.

#19

Insert six Rafix Cams (H6) into a Top (C) with the flat edges facing outwards. Tap until cams are fully seated in place as shown.

NOTE: The edge of the Rafix Cam must be aligned with the shelf edge. *Rafix Cams cannot be repositioned if installed incorrectly.*

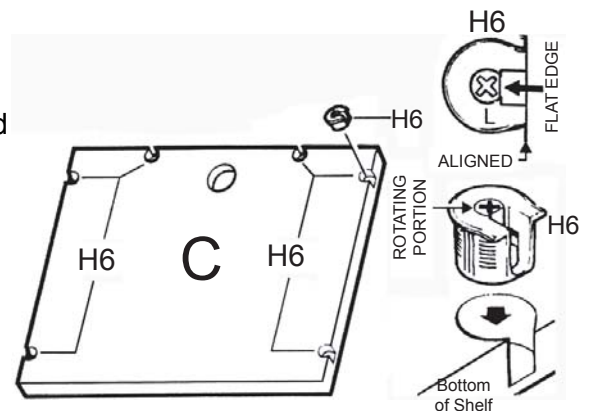

#20

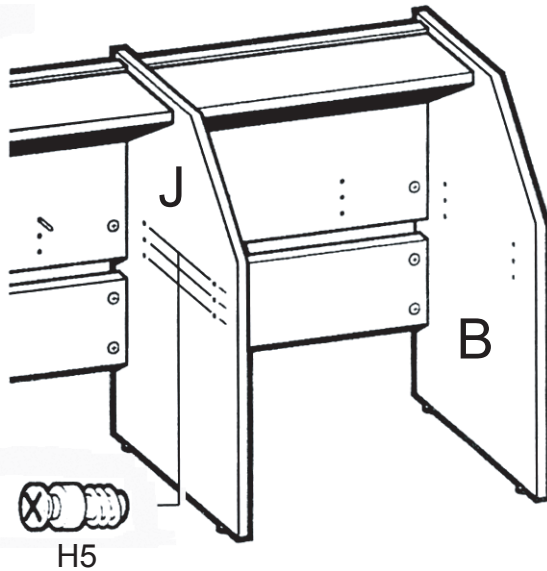

With the assistance of another person, turn the unit upright. Screw two short Rafix Bolts (H5) into the appropriate set of holes in the left side of the Divider (J).

#21

Select a preferred height of the other Top (C). Screw two Short Rafix Bolts (H5) into the right side of Divider (J) and Upper Back (D) as shown. If needed, move the Short Rafix Bolts of the Right Side (B) to a matching height.

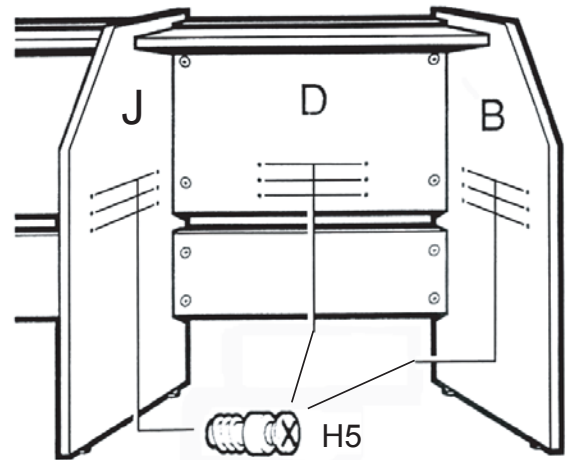

#22

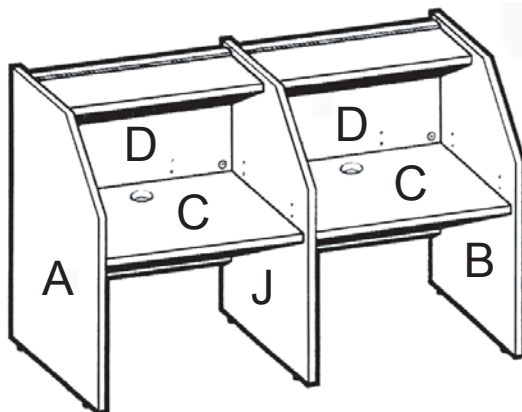

Position the Tops (C) onto the Rafix Bolts (H5) of the Left and Right Sides (A and B), Upper Backs (D) and Divider (J) as shown.

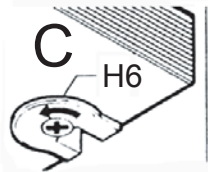

Using a #3 Phillips screwdriver, turn the rotating portions of the Rafix Cams (H6) 1/4-turn clockwise to secure.

NOTE: Do not exceed 1/4-turn when tightening!

#23

Press a Round Grommet (H7) into the holes in the Tops (C) as shown.

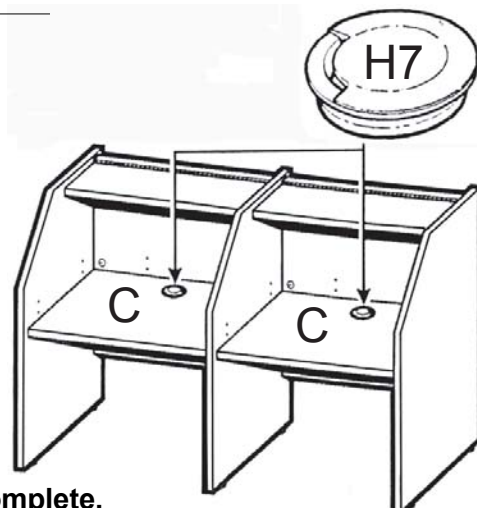

Assembly of the Study Carrel is now complete.